

**REPUBLIC OF LIBERIA**



**MINISTRY OF PUBLIC WORKS**



**MANUAL FOR LOW VOLUME ROADS**

**PART E - ROAD MAINTENANCE**

**2019**



# PART E

## ROAD MAINTENANCE

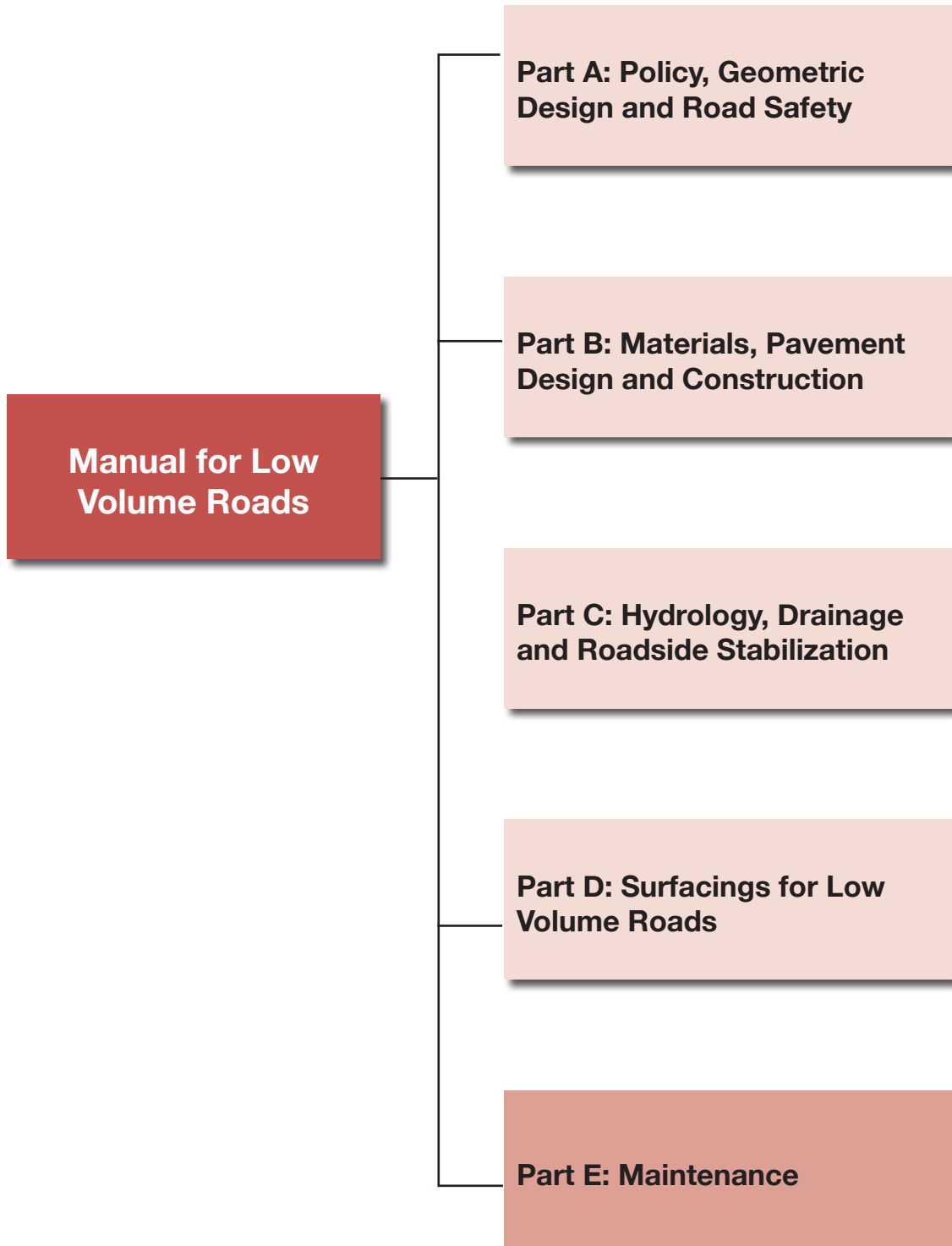



## PREFACE

**T**he rural road network in Liberia is a valuable national investment that must be preserved. Roads require regular maintenance to keep them in an acceptable condition and ensure safe passage of all types of vehicles. Effective maintenance prolongs the life of the road and ensures that the road is open to traffic in all weather conditions. Vehicle operating costs are reduced by providing a smooth-running surface, free of defects such as potholes and ruts. This results in reliable access and facilitates regular and affordable rural transport services.

The maintenance activities and codes used in this manual are based on the “Labor Based Routine Maintenance of Rural Roads in Liberia - Field Hand Book for Technicians and Group Leaders” (2013). Additional maintenance activities have been added to cover the use of intermediate and heavy equipment for road maintenance and for the maintenance of low volume sealed roads. This manual should be used in conjunction with the Ministry of Public Works Maintenance Management Manual (October 2009).

### **Manual Updates**

Significant changes to criteria, procedures or any other relevant issues related to new policies or revised laws of the land or that are mandated by the Government of Liberia will be incorporated into the manual from their date of effectiveness. Other minor changes that do not significantly affect the whole nature of the manual will be accumulated and made periodically. When changes are made and approved, new versions of the manual incorporating the revision will be issued.

All suggestions to improve the manual should be made in writing to the Ministry of Public Works, which is responsible for issuing periodic updated versions of the Manual.



**Honorable Mobutu Vlah Nyenpan**  
**MINISTER**  
**Ministry of Public Works**  
**Monrovia**  
**Republic of Liberia**

## ACKNOWLEDGEMENTS

The development of this manual has been supported by UK Aid through the Department for International Development. The preparation process was managed by the Sierra Leone Roads Authority with support from the Project Management Unit of the Research for Community Access Partnership (ReCAP) and Civil Design Solutions.

Some material for this document has been taken from the World Road Association (PIARC) International Road Maintenance Handbook. The first version of this Manual was prepared by Intech Associates under the direction of Ti-UP with funding of the UK Department for International Development (DFID). The first version was further developed into Part G of the Manual for Low Volume Roads of the Ethiopia Roads Authority under the DFID-funded Africa Community Access Partnership (AfCAP). It has now been adapted for Liberia and Sierra Leone. Diagrams are by Patricia Petts, Copyright is Intech Associates.

## SAFETY STANDARDS

Photographs have been used in this manual illustrate aspects of road maintenance. The best available photographs have been used. In some cases, good practice for health and safety is not portrayed in the photograph. All road maintenance workers should be provided with appropriate safety clothing and should work in a safe environment.

## ABBREVIATIONS, ACRONYMS AND INITIALISMS

AfCAP	:	Africa Community Access Partnership
CAV	:	Current Asset Value
CBO	:	Community Based Organisation
CBR	:	California Bearing Ratio
cm	:	Centimeter
DFID	:	UK Government's Department for International Development
e.g.	:	For example (abbreviation for the Latin phrase <i>exempli gratia</i> )
EOD	:	Environmentally Optimised Design
esa	:	Equivalent Standard Axles
i.e.	:	That is (abbreviation for the Latin phrase <i>id est</i> )
km	:	Kilometre
km <sup>2</sup>	:	Square Kilometre
km/h	:	Kilometres per Hour
LVR	:	Low Volume Road
LVSR	:	Low Volume Sealed Road
m	:	Meter
m <sup>2</sup>	:	Square meter
m <sup>3</sup>	:	Cubic meter
MCA	:	Multi Criteria Analysis
MPW	:	Ministry of Public Works
NCI	:	Network Condition Index
NFI	:	Network Functionality Index
NGO	:	Non-Government Organisation
NMT	:	Non-Motorized Transport
ORN	:	Overseas Road Note
RCI	:	Road Condition Index
ReCAP	:	Research for Community Access Partnership
RFI	:	Road Functionality Index
SMEs	:	Small and Medium Enterprises
TRL	:	Transport Research Laboratory
UK	:	United Kingdom
USD	:	United States Dollar
vpd	:	Vehicles per day

## GLOSSARY OF TECHNICAL TERMS

### **Abney level**

Small hand-held slope measuring and levelling device.

### **Aggregate**

Coarse particulate material including sand, gravel, crushed stone, slag and recycled material that forms a component of composite materials such as concrete and asphalt.

### **Aggregate brooming**

Using a broom to spread chippings on a surface.

### **Apron**

The flat invert of the culvert inlet or outlet.

### **Asphaltic concrete**

A high-quality manufactured mixture of bitumen and aggregates. Expensive and usually only used on heavily trafficked main roads.

### **Basin**

A structure at a culvert inlet or outlet to contain turbulence and prevent erosion.

### **Berm**

A low ridge or bund of soil to collect or redirect surface water.

### **Bituminous binder**

A non-crystalline solid or viscous mixture of complex hydrocarbons that possesses characteristic agglomerating properties, softens gradually when heated, is substantially soluble in trichlorethylene and is obtained from crude petroleum by refining processes. Used to bind or coat aggregates for road pavements.

### **Bitumen emulsion**

An emulsion made of bitumen and water with the addition of an emulsifier or emulsifying agent to ensure stability. Conventional bitumen emulsion most commonly used in road works has the bitumen dispersed in the water. An invert bitumen emulsion has the water dispersed in the bitumen. In the former, the bitumen is the dispersed phase and the water is the continuous phase. In the latter, the water is the dispersed phase and the bitumen is the continuous phase. The bitumen is sometimes fluxed to lower its viscosity by the addition of a suitable solvent

### **Bleeding**

Defect: Excess binder on the surface of the pavement. Normally not of critical importance on low volume roads.

### **Blinding**

A layer of lean concrete, usually 5 to 10 cm thick, placed on soil to seal it and provide a clean and level working surface to build the foundations of a wall, or any other structure.

An application of fine material e.g. sand, to fill voids in the surface of a pavement or earthworks layer.

### **Block cracking**

Defect: Interconnected cracks forming a series of large blocks usually with sharp corners or angles.

### **Brick (clay)**

A hard, durable block of material formed from burning (firing) clay at high temperature.

### **Bridge**

A structure usually with a span of 6 metres or more, providing a means of crossing above water, a railway or another obstruction, whether natural or artificial. A bridge consists of abutments, deck and sometimes wingwalls, piers and approach slabs, or may be an arch structure.

### **Camber**

The road surface is normally shaped to fall away from the center line to either side. The camber is necessary to shed rain water. The slope of the camber is called the crossfall.

**Camber board**

Apparatus for checking the crossfall of the road camber, or the shoulder.

**Cape seal**

A road surface layer formed by slurry seal laid on top of a bituminous chip seal.

**Carriageway**

The road pavement or bridge deck surface on which vehicles travel.

**Cascade**

A drainage channel with a series of steps, sometimes with intermediate silt traps or ponds, to take water down a steep slope and prevent scouring or erosion.

**Catchpit**

A manhole or open structure with a sump to collect silt.

**Catchwater drain**

See Cutoff.

**Causeway or vented drift**

Low level structure constructed across streams or rivers with openings to permit water to pass below road level. The causeway may become submerged in flood conditions.

**Check dam/ scour check**

Small barrier across a ditch or drain to reduce water velocity and reduce the possibility of erosion.

**Chippings**

Clean, strong, durable pieces of stone made by crushing or napping rock. The chippings are usually screened to obtain material in a small size range.

**Chip seal, single**

An application of bituminous binder followed by a layer of stone or clean sand. The stone is sometimes covered with a fog spray.

**Chip seal, double**

An application of bituminous binder and stone followed by a second application of binder and stone or sand. A fog spray is sometimes applied on the second layer of aggregate

**Chute**

An inclined pipe, drain or channel constructed on a slope to direct water down the slope and prevent erosion.

**Cobble stone (dressed stone)**

Cubic pieces of stone larger than setts, usually shaped by hand and built into a road surface layer or surface protection.

**Concrete**

A construction material composed of cement (commonly Portland cement) as well as other cementitious materials such as fly ash and slag cement, aggregate (generally a coarse aggregate such as gravel or crushed stone plus a fine aggregate such as sand), water, and chemical admixtures.

**Concrete block paving**

A course of interlocking or rectangular concrete blocks placed on a suitable base course and bedded and jointed with sand.

**Counterfort drain**

A drain running down a slope and excavated into it. The excavation is partly or completely filled with free draining material to allow ground water to escape.

**Cracking**

Defect: Narrow breaks in a surfacing or pavement material caused by overloading, fatigue or weakness of the material.

**Crazing (crocodile cracks)**

Defect: Interconnecting network of cracks in the road surfacing.

**Crocodile cracks**

See crazing.

**Crushed stone**

A form of construction aggregate typically produced by mining a suitable rock deposit and breaking the removed rock down to the desired size using crushers.

**Current Asset Value**

The current monetary value of a road or road network based on the condition of the road formation, surfacing and drainage system.

**Cut-off/catchwater drain**

A drain constructed uphill from a cutting face to intercept surface water flowing down the slope towards the road.

**Debris rack or grill**

Grill, grid or post structure located near a culvert entrance to hold back floating debris too large to pass through the culvert.

**Deck**

The part of a bridge that spans between abutments or pier supports and carries the road traffic.

**Distributor**

A vehicle comprising an insulated tank with heating and circulating facilities and a spray bar capable of applying a thin, uniform and predetermined layer of binder.

**Ditch (open drain)**

A long narrow excavation designed or intended to collect and drain off surface water.

**Drag**

A device towed behind a vehicle or tractor to remove minor irregularities and redistribute loose surface material.

**Dressed stone**

See Cobble Stone.

**Drift or ford**

A stream or river crossing at bed level over which the stream or river water can flow.

**Earth road**

A road built from the soil in place at the road location and provided with a camber and drainage system.

**Edge cracking**

Defect: Longitudinal cracking near the edge of the pavement.

**Embankment**

Constructed earthworks below the pavement raising the road above the surrounding natural ground level.

**Emergency maintenance**

Serious, unforeseen situations necessitating remedial action to be taken as soon as possible, e.g. flood damage, major slips.

**Excess aggregate**

Defect: aggregate particles not coated with binder after application of binder.

**Expansive soil**

Typically, a clayey soil that undergoes large volume changes in direct response to moisture changes.



**Flow spreader**

A structure designed to disperse the flow at the outfall of a ditch or drain to minimise the risk of erosion downstream.

**Fog spray**

A very light film of binder sprayed onto a road to bind or enrich the surface.

**Ford**

See Drift

**Formation**

The shaped surface of the earthworks, or subgrade, before constructing the pavement layers.

**Gabion**

Stone-filled wire or steel mesh cage. Gabions are often used as retaining walls or river bank scour protection structures.

**Glazing**

Defect: Wear or embedment of chippings in the surfacing giving a smooth, shiny appearance.

**Gravel**

A naturally-occurring, weathered rock within a specific particle size range. In geology, gravel is any loose rock that is larger than 2mm in its largest dimension and not more than 63mm.

**Hand packed stone**

A layer of large, angular broken stones laid by hand with smaller stones or gravel rammed into the spaces between stones to form a road surface layer.

**Incremental paving**

Road surface comprising small blocks such as shaped stone (setts) or bricks, jointed with sand or mortar.

**Invert**

The lowest point of the internal cross-section of a drain or culvert.

**Lengthman**

A person contracted or appointed to maintain a section of road. Can be male or female and the term 'Lengthman' assumes either sex.

**Low Volume Road**

Roads carrying up to about 300 vehicles per day and less than about 1 million equivalent standard axles over their design life.

**Macadam**

A mixture of broken or crushed stone of various sizes (usually less than 3cm) laid to form a road surface layer.

**Network Condition Index**

Aggregation of Road Condition Index scores for the entire network.

**Network Functionality Index**

Aggregation of Road Functionality Index scores for the entire network.

**Occasional maintenance**

See Periodic Maintenance.

**Otta seal**

A surface layer formed by rolling natural gravel into a soft bituminous seal coat.

**Outfall**

Discharge end of a drain or culvert.

**Parapet**

The protective edge, barrier, wall or railing at the edge of a bridge deck.

**Pass**

A single longitudinal traverse made by a grader, roller or other piece of equipment working on the road.

**Pavé**

See Sett

**Paved road**

A road with a stone, bituminous, brick or concrete surfacing.

**Pavement**

The constructed layers of the road on which the vehicles travel.

**Periodic maintenance**

Operations that are occasionally required on a section of road after a period of a number of years.

**Ravelling**

Defect: The removal of chippings/gravel/aggregate from the wearing surface due to traffic or poor bond between the aggregate and the binder.

**Regular maintenance**

Operations required to be carried out once or more per year on a section of road. These operations are typically small scale or simple, but widely dispersed.

**Reinforced concrete**

A mixture of coarse and fine stone aggregate bound with cement and water and reinforced with steel rods for added strength.

**Rejuvenator**

A material (which may range from a soft bitumen to petroleum) which, when applied to reclaimed asphalt or to existing bituminous surfacing, has the ability to soften aged, hard, brittle binders

**Reseal**

A surface treatment applied to an existing bituminous surface.

**Riprap**

Stones, usually between 5 to 50 kg, used to protect the banks or bed of a river or watercourse from scour.

**Road base**

Upper pavement layer below the surfacing.

**Road Condition Index (RCI)**

An engineering index calculated as the aggregation of visually assessed degree and extent of defects at road level.

**Road Functionality Index (RFI)**

A result of the aggregation of defects relevant to road functionality combined with the general passability of the road. An indication of the level of service offered by a road vis a vis comfort, safety and capacity at road segment level.

**Road Asset Preservation Index (RAPI)**

The ratio of the current road network Current Asset Value divided by the road network Current Replacement Value.

**Roadway**

The portion within the road margins, including shoulders, for vehicular use.

**Routine maintenance**

See Regular Maintenance

**Sand Seal**

A surface layer formed by sand laid onto a bituminous seal coat.

**Scarify**

The systematic disruption and loosening of the top of a road or layer surface by mechanical or other means.

**Scour**

Defect: Erosion of a channel bed area by water in motion, producing a deepening or widening of the channel.

**Scour check**

See check dam

**Selected layers**

Pavement layers of selected gravel materials used to bring the subgrade support up to the required structural standard for placing the subbase or base course.

**Sett (Pavé)**

A small piece of hard stone trimmed by hand to a size of about 10cm cube used as a paving unit.

**Shoulder**

Paved or unpaved part of the roadway next to the outer edge of the pavement. The shoulder provides side support for the pavement and allows vehicles to stop or pass in an emergency.

**Slip**

Defect: Slope material sliding downhill because of instability, water penetration or flow.

**Slurry seal**

A mixture usually containing fine graded aggregates, water; bitumen emulsion, cement and sometimes an additive, spread on the road surface by a specially equipped machine, or by hand.

**Sods**

Turf with more soil attached (usually more than 10 cm).

**Soffit**

The highest point in the internal cross-section of a culvert, or the underside of a bridge deck.

**Spray lance**

Apparatus permitting hand-application of bituminous binder at a desired rate of spread through a nozzle.

**Streaking**

Defect: Alternate lean and heavy lines of bitumen running parallel to the pavement center line, caused by blocked or incorrectly set spray nozzles.

**Stripping**

Defect: The removal of binder/bitumen due to poor bond between the aggregate and bitumen or presence of moisture.

**Sub-base**

The pavement layer below the Road Base.

**Subgrade**

The native material underneath a constructed road pavement.

**Sub-soil drainage**

System of pervious pipes or free draining material designed to collect and carry water in the ground.

**Surface dressing**

A sprayed or hand applied film of bitumen followed by the application of a layer of stone chippings, which is then rolled.

**Surface treatment**

Construction of a protective surface layer e.g. by spray application of a bituminous binder, blinded with coated or uncoated aggregate.

**Surfacing**

Top layer of the pavement. Consists of wearing course, and sometimes a base course or binder course. The layer with which traffic makes direct contact.

**Tack coat**

A coat of bituminous binder applied to a primed layer or to an existing bituminous surface as a preliminary treatment to promote adhesion between the existing surface and a subsequently applied bituminous layer.

**Transverse joint**

Joint perpendicular to the road center line.

**Turf**

A portion of grass obtained by excavating an area of live grass and lifting the grass complete with about 5 cm of topsoil and roots still attached.

**Turn-out drain (mitre drain)**

A drain that leads water away from the side drains to the adjoining land.

**Unpaved road**

A road with an earth or gravel surface.

**Vented drift**

See Causeway.

**Waterbound macadam**

A pavement layer constructed where the voids in a large single-sized stone skeleton are filled with a fine sand.

**Wearing course**

The upper layer of a road pavement on which the traffic runs and is expected to wear under the action of traffic.

**Weephole**

An opening provided in retaining walls or bridge abutments to permit drainage of water in the filter layer or soil layer behind the structure and prevent water pressure building up behind the structure.

**Windrow**

A ridge of material formed by the spillage from the end of the machine blade or continuous heap of material formed by labor.

**Wingwall**

Retaining wall at a bridge abutment to retain and protect the embankment fill behind the abutment.

## TABLE OF CONTENTS

<b>PREFACE</b> .....	<b>I</b>
<b>ACKNOWLEDGEMENTS</b> .....	<b>II</b>
<b>SAFETY STANDARDS</b> .....	<b>II</b>
<b>ABBREVIATIONS, ACRONYMS AND INITIALISMS</b> .....	<b>III</b>
<b>GLOSSARY OF TECHNICAL TERMS</b> .....	<b>IV</b>
<b>TABLE OF CONTENTS</b> .....	<b>XI</b>
<b>LIST OF FIGURES</b> .....	<b>XIII</b>
<b>LIST OF TABLES</b> .....	<b>XIII</b>
<b>1. MANUAL FOR LOW VOLUME ROADS</b> .....	<b>1</b>
1.1 Manual for Low Volume Roads .....	1
1.2 Road Features .....	1
1.3 Road Surface Types .....	3
1.4 Road Deterioration .....	5
1.4.1 Causes of Deterioration .....	5
1.4.2 Water .....	5
1.4.3 Traffic .....	5
1.4.4 Construction quality .....	5
1.5 Consequences of Inadequate Road Maintenance .....	5
<b>2. ROAD MAINTENANCE ACTIVITIES</b> .....	<b>7</b>
2.1 Purpose of Maintenance .....	7
2.2 Types of Maintenance .....	7
2.3 Routine (Regular) Maintenance .....	7
2.3.1 Maintenance Activities.....	7
2.3.2 Roadside Activities .....	8
2.3.3 Drainage, Retaining Walls and Road Furniture.....	8
2.3.4 Retaining Walls and Road Furniture .....	9
2.3.5 Road Surface Maintenance .....	9
2.4 Periodic (Occasional) Maintenance.....	10
2.5 Spot Improvements.....	10
2.6 Maintenance Activities .....	10
2.7 Road Maintenance Tools.....	54
<b>3. MAINTENANCE MANAGEMENT CYCLE</b> .....	<b>55</b>
3.1 Introduction .....	55
3.2 Road Inventory .....	55
3.3 Drainage Structure Inventory .....	55
3.4 Prioritisation of Maintenance Works.....	55
3.4.1 Principles of Prioritisation.....	55
3.4.2 Prioritisation Process.....	56



3.5	Assessing Maintenance Needs .....	57
3.5.1	Annual Condition Survey .....	57
3.5.2	Monthly Condition Survey .....	57
3.6	Preparation of Maintenance Work Plans .....	57
3.7	Supervision and Reporting .....	57
3.8	Road Improvement and Emergencies .....	58
<b>4.</b>	<b>WORK OPTIONS.....</b>	<b>58</b>
4.1	Summary of Options .....	59
4.2	Option 1- Small Contractor (Private) .....	59
4.3	Option 2 – Large Contractor Based System .....	59
4.4	Option 3 – Force Account .....	60
4.5	Option 4 – Hire-in equipment .....	60
4.6	Option 5 – Community Based Organisation (CBO) .....	61
4.7	Option 6 – Length Person or Family Contract .....	61
4.8	Option 7 – Voluntary Labor.....	62
4.9	Forms of Contract .....	63
	Remeasured contract.....	63
	Performance-based contract .....	63
4.10	Area-based road maintenance .....	63
<b>5.</b>	<b>WORK PLANNING AND PRODUCTIVITY .....</b>	<b>65</b>
5.1	Outline Planning Guide.....	65
5.2	Productivity Targets.....	65
<b>6.</b>	<b>SAFETY DURING MAINTENANCE OPERATIONS.....</b>	<b>68</b>
<b>7.</b>	<b>MAINTENANCE OF BRIDGES &amp; STRUCTURES .....</b>	<b>69</b>
7.1	General Requirements.....	69
7.2	Managing Structures .....	69
7.3	Maintenance Activities .....	70
7.4	Common Structure Maintenance Requirements.....	71
7.4.1	Scour .....	71
7.4.2	Drifts .....	71
7.4.3	Culverts.....	71
7.4.4	Vented Drifts and Large Bore Culverts .....	72
7.4.5	Bridge maintenance.....	73
	<b>APPENDIX E.1: SPECIFICATIONS FOR MAINTENANCE OF LOW VOLUME ROADS .....</b>	<b>75</b>
	<b>APPENDIX E.2: REFERENCES AND FURTHER ADVICE.....</b>	<b>96</b>
	<b>APPENDIX E.3: ROAD INVENTORY DATA COLLECTION FORM.....</b>	<b>97</b>
	<b>APPENDIX E.4: CULVERT INVENTORY FORM .....</b>	<b>98</b>
	<b>APPENDIX E.5: BRIDGE INVENTORY FORM.....</b>	<b>99</b>
	<b>APPENDIX E.6: ROAD CONDITION ASSESSMENT FORMS.....</b>	<b>100</b>
	<b>APPENDIX E.7: STRUCTURE CONDITION ASSESSMENT FORM .....</b>	<b>102</b>
	<b>APPENDIX E.8: ROAD MAINTENANCE SURVEY FORM.....</b>	<b>104</b>

## LIST OF FIGURES

Figure E.1.1: Typical road cross section .....	2
Figure E.1.2: Importance of road camber .....	2
Figure E.1.3: Typical drainage features .....	3
Figure E.1.4: Erosion of gravel on a hill section and dusty conditions .....	4
Figure E.1.5: Examples of alternative surfacings for LVRs .....	4
Figure E.1.6: Cycle of inadequate road maintenance .....	6
Figure E.1.7: Relationship between maintenance standard and transport cost.....	6
Figure E.1.8: The cost of deferred maintenance.....	6
Figure E.2.1: Road condition deterioration with time.....	7
Figure E.2.2: Road maintenance hand tools.....	54
Figure E.3.1: The Road Maintenance Management Cycle .....	55
Figure E.4.1: Maintenance base camp in Zimbabwe.....	64
Figure E.6.1: Sign posting for diversion of traffic off the road .....	68
Figure E.6.2: Sign posting for diversion of traffic to one side of the road .....	68
Figure E.7.1: Box culvert partially blocked by vegetation.....	72
Figure E.7.2: Cleaning the drop inlet and barrel of a large bore culvert.....	73

## LIST OF TABLES

Table E.2.1: Roadside activities .....	8
Table E.2.2: Drainage activities .....	8
Table E.2.3: Retaining walls and road furniture.....	9
Table E.2.4: Earth road carriageway maintenance activities.....	9
Table E.2.5: Gravel road carriageway maintenance activities.....	9
Table E.2.6: Paved road carriageway maintenance activities .....	10
Table E.2.7: Gravel or paved road periodic maintenance activities .....	10
Table E.3.1: Example of simplified road prioritisation .....	56
Table E.3.2: Reporting structure .....	58
Table E.5.1: Outline routine maintenance planning for LVRs .....	65
Table E.5.2: Productivity targets per person-day.....	66
Table E.7.1: Structure maintenance activities (routine).....	70
Table E.7.2: Structure maintenance activities (periodic).....	71

# 1. MANUAL FOR LOW VOLUME ROADS

## 1.1 Manual for Low Volume Roads

The Manual for Low Volume Roads for Liberia provides detailed guidance on the design, construction and maintenance of rural roads. It caters for roads carrying less than 300 vehicles per day or one million equivalent standard axles over the design life. The Manual promotes the rational, appropriate, and affordable provision and maintenance of roads, with cost effective and sustainable use of local resources. The Manual reflects local experience and advances in low volume road technology gained in Liberia and elsewhere.

The Manual for Low Volume Roads is adaptable for different clients and users. It has application for roads at a national and district level administered by the Ministry of Public Works and local authorities. It caters for interventions that deal with individual critical areas on a road link (spot improvements) through to providing complete designs for new rural roads and road maintenance. The Manual comprises the following Parts:

- Part A: Policy, Geometric Design and Road Safety
- Part B: Materials, Pavement Design and Construction
- Part C: Hydrology, Drainage and Roadside Stabilisation
- Part D: Surfacing for Low Volume Roads
- Part E: Maintenance

Part E provides guidance for Ministry staff, local authorities, Non-Governmental Organisations and local communities on how to:

- identify the main problems and defects on roads and how to solve them;
- maintain drainage and other structures;
- set priorities for maintenance works;
- specify road maintenance activities; and
- organize and plan the work.

## 1.2 Road Features

The main features of a rural road are:

- the road reserve (Right of Way);
- the road formation;
- the road pavement;
- surfacing on the road;
- side drains and turn-out drains;
- cross drainage structures including culverts, drifts, fords and bridges; and
- road signs and road markings.

Guidance for the design of the main road features and the minimum design standards for Liberia are given in Parts A, B and C of the Manual for Low Volume Roads. Guidance is also given on road sector policy, planning for road works and construction issues.

Figure E.1.1 shows the typical road cross section. The camber is required to shed rainwater to each side of the road. Side drains (ditches), turnout drains (mitre drains), drifts and culverts are required to manage the water collected from the road surface and to discharge it safely away from the road, avoiding erosion or other problems. The road surface should be higher than the surrounding ground in order for the drainage system to function effectively.

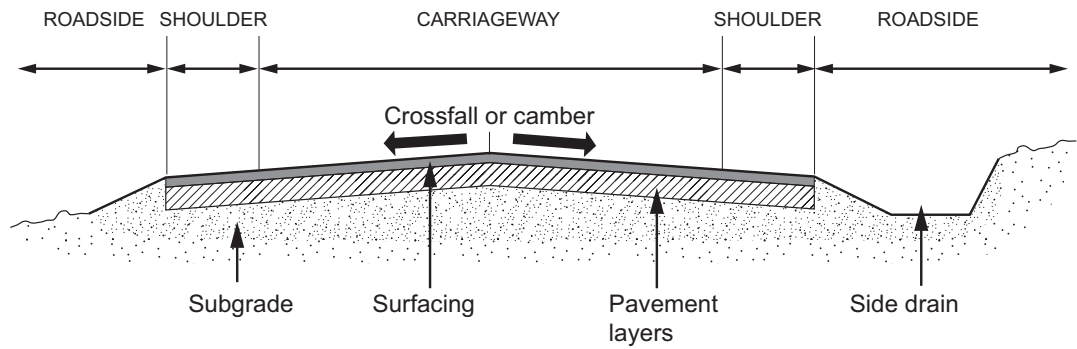
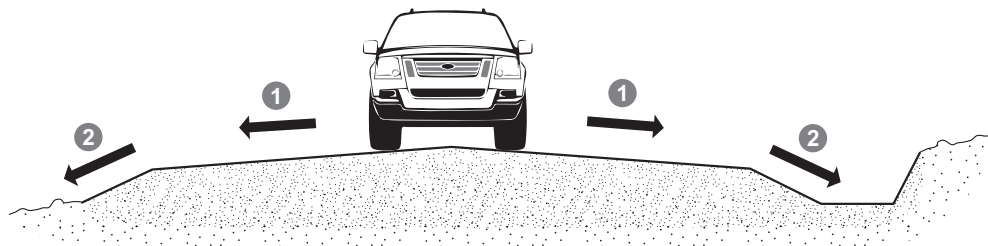

**Figure E.1.1: Typical road cross section**

**Notes:**

- The road shoulder is normally constructed of the same material as the carriageway. However, on paved roads the surfacing might not extend across the shoulders.
- Side drains may be required on both sides of the road.
- On earth and gravel roads the camber should be between 4% and 6%.
- On paved roads the camber should be between 2% and 3%.

The importance of the road camber on earth and gravel roads is illustrated in Figure E.1.2.



Drainage of an earth or gravel road is achieved by:

- ① Maintaining cross fall (camber) to drain rain water off the road and;
- ② Ensuring that rain water flows from the edge of the road surface (the shoulder) into the side drains, or down the embankment slopes, and away from the road

**Figure E.1.2: Importance of road camber**

The typical drainage features of a rural road are shown in Figure E.1.3.

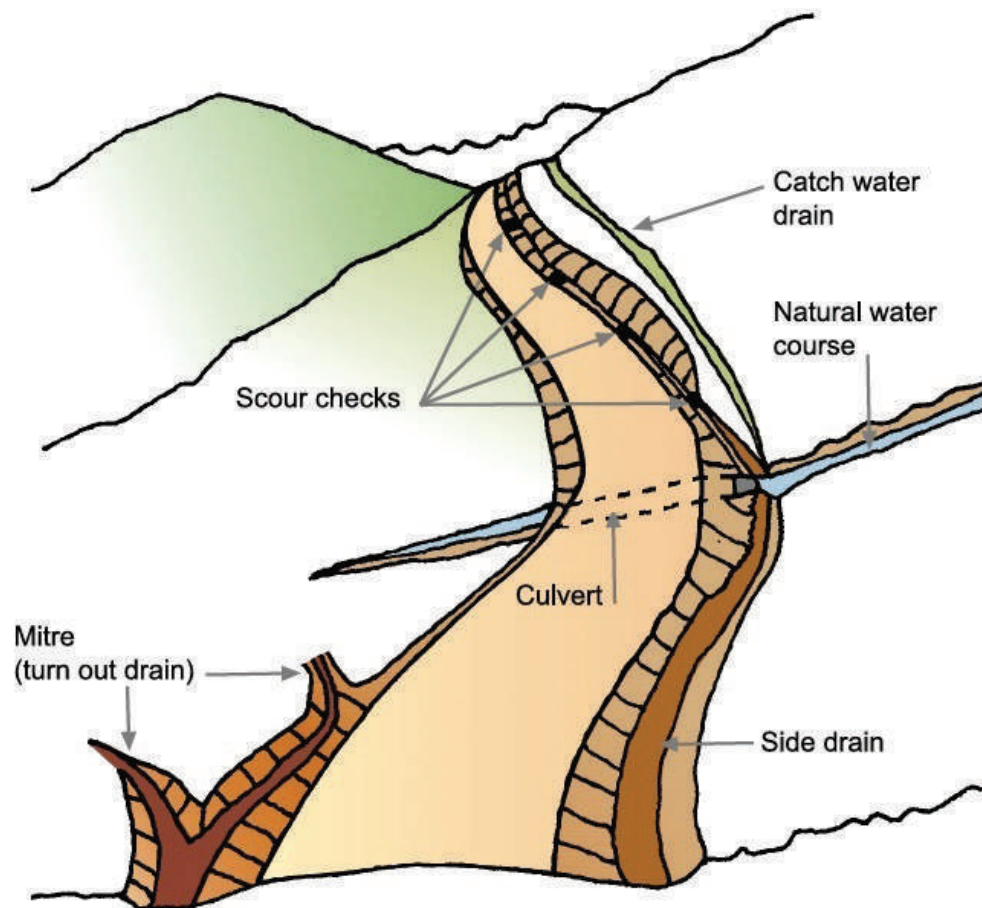

Figure E.1.3: Typical drainage features

### 1.3 Road Surface Types

Low volume rural roads are normally constructed to gravel or earth standard. As more resources become available, and traffic levels increase, other surface types may be introduced on a spot improvement or whole link basis.

Some natural soils can be built into an earth road. The design of earth roads is described in Part B of the Manual for Low Volume Roads. For road sections on weak soils, or if traffic increases to more than about 50 motor vehicles per day, or on steep hills, or through settlements, it is normally necessary to improve the road surface with gravel or a paved surface.

The surface types that may be used on Low Volume Roads include:

- Earth road;
- Natural gravel (including crushed and screened material);
- Waterbound / Drybound Macadam;
- Hand Packed Stone;
- Stone Setts or Pavé;
- Mortared Stone;
- Dressed stone / Cobble stone;
- Fired Clay Brick, Unmortared / Mortared joints;
- Bituminous Sand Seal;
- Bituminous Slurry Seal;
- Bituminous Chip Seal;
- Bituminous Cape Seal;
- Bituminous Otta Seal or Gravel Seal;



- Bituminous Cold Mix Asphalt;
- Non-reinforced concrete slabs; and
- Reinforced concrete slabs.

Gravel is the most common form of improved surfacing for rural roads. However, gravel may not be a suitable long-term option as a surfacing material under certain conditions due to the high cost of replacement of gravel lost as a result of erosion and traffic. These conditions include:

- Traffic is more than 200 motor vehicles per day;
- Annual rainfall is greater than 2,000 mm;
- The slope of road surface is more than 6%;
- The haulage distance from the gravel quarry/pit to the road site is more than 10km;
- The road section experiences frequent flooding; and
- The gravel found in the vicinity of the road is of poor quality.

Gravel roads create a dust nuisance to communities living close to the road. Dust can cause respiratory health problems, particularly for children.



**Figure E.1.4: Erosion of gravel on a hill section and dusty conditions**

Erosion of gravel surfaces is eliminated by providing an improved surfacing on the road. Dust is also reduced. The improved surfacings are more expensive to construct than a gravel wearing course but may have lower long-term maintenance and replacement costs. Examples of improved surfaces are shown in Figure E.1.5.



Surface dressing (chip seal)



Concrete strips

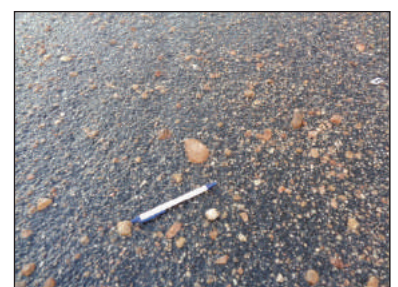

Otta Seal



Cold Mix Asphalt



Concrete blocks



Concrete slabs

**Figure E.1.5: Examples of alternative surfacings for LVRs**

## 1.4 Road Deterioration

### 1.4.1 Causes of Deterioration

The principal causes of deterioration of a road are:

- the effects of environment (predominately water);
- the effects of traffic; and
- construction quality.

### 1.4.2 Water

Rain water collects in small depressions in the road and soaks through the surfacing into the pavement and sub-grade. This results in soft spots which develop into potholes as the wheels of vehicles pass over them. On steep sections of the road, the rainwater runs more quickly downhill, causing erosion gullies and washing away the gravel layer. Erosion on the side slopes results in loss of the road shoulders and narrowing of the useable road width. On flat sections of road, rainwater in the side drains flows slowly and deposits silt in the bottom of the drain. Once the drains are silted this may result in ponding of water on the roadway, which causes softening of the road base leading to the formation of ruts and potholes.

When culverts become blocked the roadway acts as a dam blocking all the water on the upstream side of the road from following its natural course downstream. The trapped water soaks into the road base or may overtop the road causing erosion across the road. The culvert may be washed out.

### 1.4.3 Traffic

Traffic on the roadway leads to defects on the road surface. On gravel and earth roads the vehicles wear away the surface of the road by pushing the surface material off the road and eventually flattening the original camber. The deformed camber prevents water from flowing into the side drains. Vehicles also tend to follow in the same wheel tracks along the road and this eventually leads to rutting of the surface. If the road is on a slope the rainwater flows in the rut causing further erosion and the formation of gullies.

Traffic may cause corrugations to form across the road. These are closely spaced ridges which form as a result of the action of the vehicle suspension on some types of soils. Corrugations result in a rough surface which increase wear and tear to the vehicles.

On paved roads vehicles cause rutting and potholes where moisture has entered the pavement layers or subgrade through cracks in the surface or from the sides of the road. The moisture in the pavement causes the material to lose its strength.

### 1.4.4 Construction quality

Poor construction quality results in more rapid deterioration of the road. Construction defects may include incorrect camber, use of poor quality materials and inadequate compaction of the pavement layers.

## 1.5 Consequences of Inadequate Road Maintenance

The cycle of inadequate maintenance is illustrated in Figure E.1.6. Inadequate maintenance leads to poorly maintained road surfaces which results in increased vehicle depreciation, tire wear, vehicle maintenance and need for spare parts. The user costs and operating inefficiency related to these increases are substantial for the entire fleet of vehicles in Liberia and many of these costs are in foreign exchange. Thus, the provision of effective and efficient road maintenance by roads authorities is of critical economic importance to Liberia.

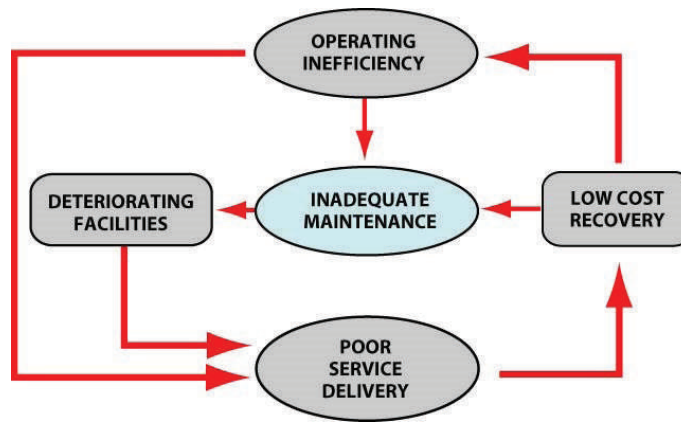

Figure E.1.6: Cycle of inadequate road maintenance

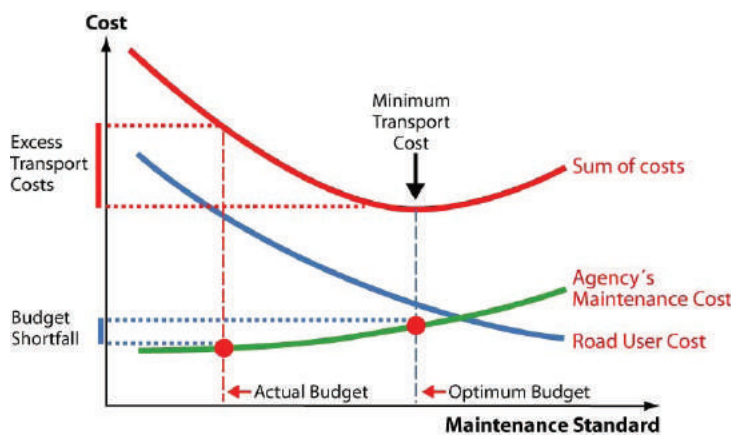

Figure E.1.7: Relationship between maintenance standard and transport cost

When a road is not maintained adequately and is allowed to deteriorate from good to poor condition, each Liberian Dollar (LRD) saved from not carrying out maintenance increases vehicle operating costs by two to three LRD. This is illustrated in Figure E.1.7. Cutting back on road maintenance (“budget shortfall”) increases the costs of road transport (“excess transport costs”) and raises the net cost to the national economy.

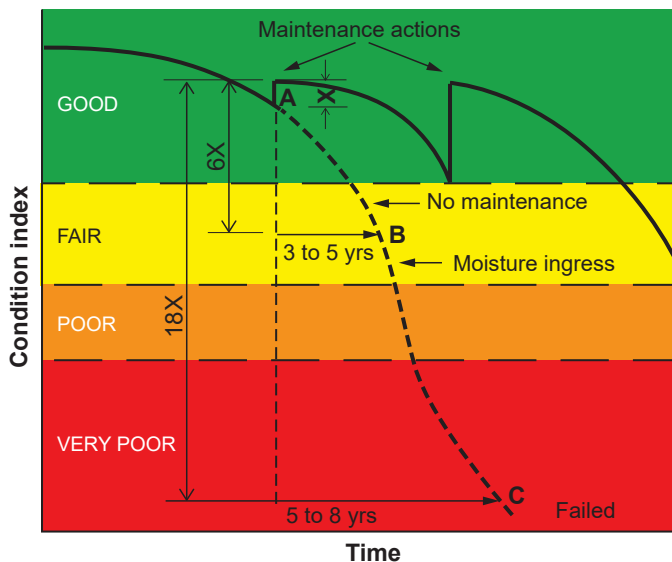

Figure E.1.8: The cost of deferred maintenance

When routine and periodic road maintenance is deferred, and the road is allowed to deteriorate, the cost of restoring the road to a good condition is very high. This is illustrated in Figure E.1.8, which applies to a paved road. If the road is allowed to deteriorate into a very poor condition (Point C), the cost of rehabilitation can be as much as 18 times the cost of the deferred maintenance, or six times the cost of the deferred maintenance if the road is in a fair condition (Point B).

Source: South Africa National Roads Agency Limited (SANRAL).

## 2. ROAD MAINTENANCE ACTIVITIES

### 2.1 Purpose of Maintenance

From the moment that a road is constructed or upgraded, it will deteriorate due to the effects of weather and traffic. Maintenance is required to be carried out from time to time to restore the condition of the road to be close as possible to its as-constructed state. If maintenance is not carried out the road will continue to deteriorate making passage increasingly difficult, unsafe, uncomfortable and expensive for road users. The road may even become impassable for part or all of the year.

Fully funded maintenance of rural roads requires approximately 3% to 5% of the initial investment construction cost of the road each year. Failure to provide the required resources to carry out proper maintenance can result in deterioration and loss of the road asset value of more than 15% each year.

### 2.2 Types of Maintenance

It is convenient to view **maintenance** as correcting **defects**. Defects are identified and quantified and the necessary maintenance organised to correct the defects. In this Manual, maintenance activities are grouped as:

- Routine (Regular) Maintenance;
- Periodic (Occasional) Maintenance; and
- Spot Improvements.

The relationship between routine and periodic maintenance and their influence on road deterioration is illustrated in Figure E.2.1

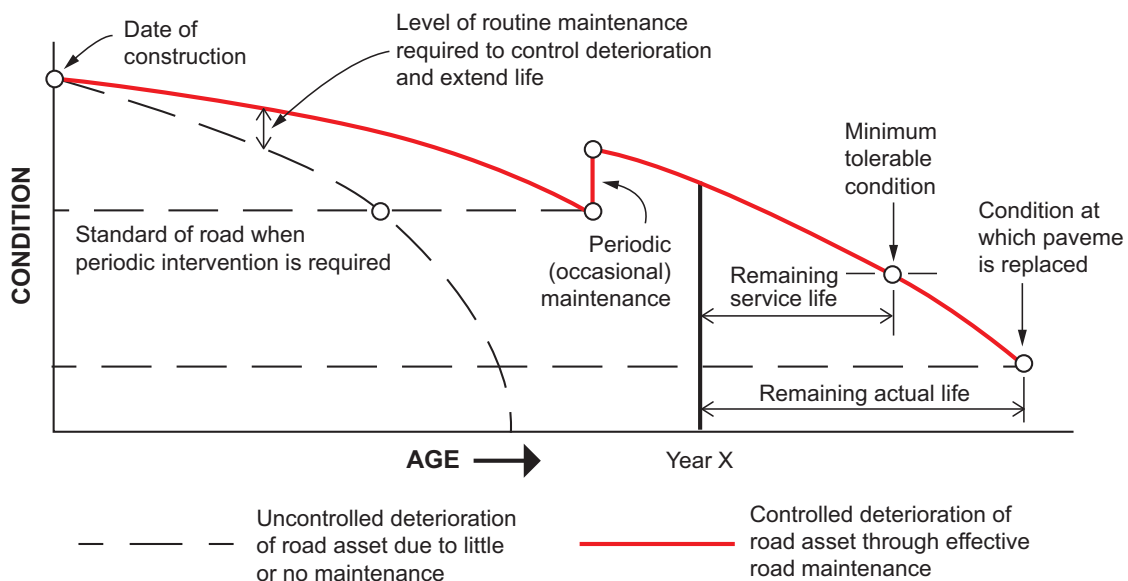

**Figure E.2.1: Road condition deterioration with time**

The maintenance of bridges and other major drainage structures is covered in Chapter 7.

From time to time, other activities not covered in detail by this Manual may be required. This may include emergency repairs due to flooding or other climatic events. Advice should be obtained from the Ministry of Public Works for any problem or road maintenance aspect not covered in this Manual.

### 2.3 Routine (Regular) Maintenance

#### 2.3.1 Maintenance Activities

Routine maintenance activities are required for the full length of a road link every year. Many of the tasks may be carried out manually. Mechanized alternatives are available for some tasks as indicated. Reshaping of the road carriageway (to restore the camber) and compaction are the only tasks that are best carried out using equipment.

Routine maintenance is divided into four main groups of activities that are often carried out on a seasonal basis:

- Roadside activities;
- Drainage system;
- Retaining walls and road furniture; and
- Road surface (earth road, gravel road and paved road).

### 2.3.2 Roadside Activities

The typical roadside maintenance activities are summarised in Table E.2.1.

**Table E.2.1: Roadside activities**

Defect	Maintenance Activity
1. Obstructions in the road reserve	1-01 Inspection of the road 1-02 Remove obstructions
2. Grass, weeds, bushes or trees overgrown on the roadside	2-02 Bush clearing and tree removal 2-03 Grubbing
3. Slope erosion (minor)	3-01a Plant grass by seeding 3-01b Plant grass by turfing

### 2.3.3 Drainage, Retaining Walls and Road Furniture

The typical maintenance activities for the road drainage system are summarised in Table E.2.2.

**Table E.2.2: Drainage activities**

Defect	Maintenance Activity
4. Culvert/drift silted/obstructed	4-01 Culvert/drift cleaning 4-01 Culvert/drift cleaning
5. Drain silted	5-01 Drain cleaning (manual) 5-02 Drain cleaning (mechanized)
6. Drain or slope eroded (minor)	6-01 Construct or replace stone or wooden scour Check (check dams). 6-02 Stone masonry lining 6-03 Concrete lining
7. Drain eroded (major)	7-01 Repair erosion damage (rockfill) 7-02 Gabion check dam



### 2.3.4 Retaining Walls and Road Furniture

The typical maintenance activities for retaining walls and road furniture are summarised in Table E.2.3.

**Table E.2.3: Retaining walls and road furniture**

Defect	Maintenance Activity
8. Gabion structure damaged	8-01 Gabion structure repair
9. Mortared masonry damaged	9-01 Mortared masonry repair
10. Dry masonry damaged	10-01 Dry masonry repair
11. Road sign dirty or defective	11-01 Clean road sign 11-02 Replace road sign

### 2.3.5 Road Surface Maintenance

Maintenance requirements for the road surface depend on the road surface type. The requirements for earth roads are different from the requirements for gravel roads and paved roads.

#### Earth Roads

The typical activities for the maintenance of the carriageway on earth roads are summarised in Table E.2.4.

**Table E.2.4: Earth road carriageway maintenance activities**

Defect	Maintenance activity
12. Road surface potholed, rutted or uneven, and does not drain to shoulder	12-01 Reshape and compact earth road (labor-based) 12-02 Reshape and compact earth road (equipment-based)

#### Gravel Roads

The typical activities for the routine maintenance of the carriageway on gravel roads are summarised in Table E.2.5.

**Table E.2.5: Gravel road carriageway maintenance activities**

Defect	Maintenance activity
13. Road surface potholed and/or with erosion gullies.	13-01 Spot repair with selected material
14. Road surface rutted or uneven, and does not drain to shoulder (minor)	14-01 Light reshaping, manual method 14-02 Light reshaping, mechanized method
15. Road Surface rutted or uneven, and does not drain to shoulder (major)	15-01 Grading gravel road (heavy)
16. Corrugations in road surface	16-01 Tire dragging

### Paved Roads

The typical activities for the routine maintenance of the carriageway on paved roads are summarised in Table E.2.6.

**Table E.2.6: Paved road carriageway maintenance activities**

Defect	Maintenance activity
17. Paved road surface defect	17-01 Pothole or spot repair (sealed road) 17-02 Pothole or spot repair (unmortared stone or brick) 17-03 Pothole or spot repair (mortared stone or brick) 17-04 Edge break repair 17-05 Crack sealing
18. Shoulder uneven or eroded (minor)	18-01 Shoulder grading (mechanized)

## 2.4 Periodic (Occasional) Maintenance

Periodic maintenance activities are required on a gravel or paved road after a number of years. The category of repair and its frequency depends on the type of road surface constructed. For example, regravelling of unpaved roads is normally required more frequently than resealing of paved roads. All of the Periodic Maintenance tasks may be carried out manually with the aid of simple tools, vehicles for the haulage of materials, and compaction equipment. The typical activities for the periodic maintenance of low volume roads are summarised in Table E.2.7

**Table E.2.7: Gravel or paved road periodic maintenance activities**

Defect	Maintenance activity
19. Shoulder uneven or eroded with edge drop (major)	19-01 Shoulder repair (manual) 19-02 Shoulder repair (mechanized)
20. Gravel layer too thin	20-01 Regravelling
21. Embrittlement of the surfacing due to hardening of the binder resulting in loss of aggregate, excessive potholes and cracking.	21-01 Reseal the road
22. Worn or covered road markings.	22-01 Replace road markings



## 2.5 Spot Improvements

Spot improvements may be carried out as part of the annual maintenance programme. They include isolated works needed to guarantee all-weather access for the traffic using the roads. Spot improvements may include the installation of a new culvert or drift to resolve a specific drainage problem on the road, or the construction of improved surfacing on a short section of road on a slope that is vulnerable to erosion. Spot improvements are normally carried out on very low traffic roads and tracks where speed of travel is not important, and therefore have a low priority for routine or periodic maintenance.

## 2.6 Maintenance Activities

Each of the typical road defects is described in the following schedules along with a description of the maintenance activity required to remedy the defect. Specifications that can be used in tender and contract documents are included in Annex E.2. Guidance on the maintenance of bridges and large drainage structures is given in Chapter 7.

<b>Defect 1</b>	<b>Obstructions in the road reserve</b>	
<b>Development, if neglected</b>	<ul style="list-style-type: none"> <li>▪ Danger to road users</li> <li>▪ Blockage of drainage system</li> </ul>	
<b>Maintenance Activities</b>	<b>1-01 Inspection of the road</b> <b>1-02 Removal of obstructions</b>	This is a Routine Maintenance activity that should be carried out on a regular basis by the road agency or the maintenance contractor.
<b>Inspection and removal of obstructions (1-01)</b>	An inspection is carried out of the entire length of the road including the carriageway and the road reserve area. Any obstructions in the road are identified, removed and safely disposed of. Obstructions may include dead animals, fallen rocks, abandoned vehicles, earth slips, fallen trees, etc.	
<b>Removal of obstructions (1-02)</b>	<p>An object causing obstruction to normal traffic movement or causing danger or discomfort to road users or interfering with normal functioning of any of the road elements or features must be removed and safely disposed of.</p> <p>Dead animals should be buried in a hole of minimum 1 metre deep located outside the formation width but within road reserve. Disposable hand gloves should be used to handle the dead animal.</p> <p>Fallen trees should be chopped into movable pieces using a chainsaw or bow saw and removed from the formation width. They should be deposited in the road reserve away from road side developments and away from the drainage system.</p> <p>Rocks and boulders should be pushed off the road using a crow bars and timber rollers if necessary. The boulders should be pushed off the road formation to the lower side taking advantage of gravity and slope. Any damage to the road surface from rolling a boulder must be repaired. The boulder must be supported in a stable position to avoid possible rolling and damage to people or property downhill.</p> <p>Litter found in the road reserve must be collected and safely disposed of. This activity is covered under 2-01.</p>	

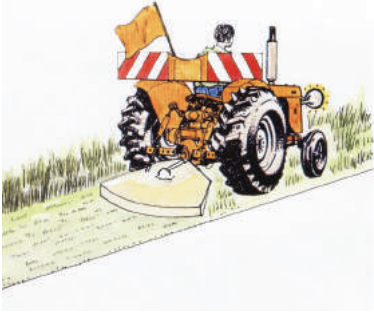
<p><b>Defect 2</b></p>	<p><b>Grass, weeds, bushes or trees overgrown on the roadside</b></p>	
<p><b>Development, if neglected</b></p>	<ul style="list-style-type: none"> <li>▪ Drainage ditches cannot be cleaned;</li> <li>▪ Surface water can pond at the edge of the road and weaken the road surface;</li> <li>▪ Silt can accumulate at the edge of the road;</li> <li>▪ The road width is reduced and visibility for road users is impeded, with increased risk of accidents with persons or animals;</li> <li>▪ Increased fire hazard in the dry season.</li> </ul>	
<p><b>Maintenance Activities</b></p>	<p><b>2-01 Grass cutting (manual or mechanized)</b> <b>2-02 Bush clearing &amp; tree removal</b> <b>2-03 Grubbing</b></p>	<p>These activities involving control of grass, weeds, bush and trees where these are not controlled by animal grazing. They should be carried out at least once a year after the rainy season, or more often where the climate causes vegetation to grow rapidly. It may be necessary to carry out both activities or only one.</p> <p>Grubbing of edge of road is carried out to widen the road and ensure rain water can run off the road into the side drains.</p>
<p><b>Grass cutting (manual) (2-01a)</b></p>	<p>Grass and weeds should be cut at least once a year or when its height exceeds 100cm. Sickles, scythes, slashers, bush knives, or similar hand tools are required.</p>	 <p style="text-align: center;"><b>Grass cutting- manual</b></p>
<p><b>Grass cutting (mechanized) (2-01b)</b></p>	<p>The grass may be cut by mechanized methods such as by a tractor powered mower.</p>	 <p style="text-align: center;"><b>Grass cutting - mechanized</b></p>

<p><b>Bush clearing &amp; trees (2-02)</b></p>	<p>Any bushes on the road shoulders or drains should be cut down. Dead or leaning trees within the right-of-way which may fall on the roadway or block the drainage system or block sight lines or cause an obstruction to high vehicles should be removed.</p> <p>The felling of trees, or the removal of large branches at heights of more than 2 metres above ground level can be hazardous. This work should only be carried out under expert supervision or by experienced workers. Trees should be felled using one- or two-man saws or axes. Ladders should be used for climbing trees, and ropes should be used to restrain trees and control felling. Traffic should be halted when the tree is finally toppled. All debris should be removed and disposed of safely.</p>
<p><b>Grubbing (2-03)</b></p>	<p>Grass growing along the edge of road should be removed using a hoe, without removing excess gravel or earth material from the road shoulder. Grass growing on the edge of the road that does not impede the flow of water from the road should be left in place as it stabilizes the road shoulder.</p>
<p><b>Disposal of debris</b></p>	<p>All cuttings and debris should be disposed of safely so that there is no risk of drains being blocked or fire hazard.</p>
<p><b>Herbicides</b></p>	<p>Herbicides (weed-killers) are chemical agents intended to destroy or reduce vegetation growth. It is not recommended that herbicides or any chemical methods be used to control roadside vegetation. Herbicides can cause pollution of crops, rivers and streams and drinking water supplies. They are often dangerous to health and require training in their safe use. They are expensive and may not always produce satisfactory results.</p>
<p><b>Burning</b></p>	<p>Roadside vegetation should not be burnt to control its growth. The debris from bush clearing activities should not be burnt. The results may be more harmful than desired:</p> <ul style="list-style-type: none"> <li>▪ The fire could spread and destroy valuable vegetation (trees, grass or crops), and traffic signs;</li> <li>▪ Vegetation may grow faster after burning;</li> <li>▪ Smoke and flames blowing across the road are dangerous for traffic.</li> </ul>





**Use of herbicides**





**Burning roadside vegetation**

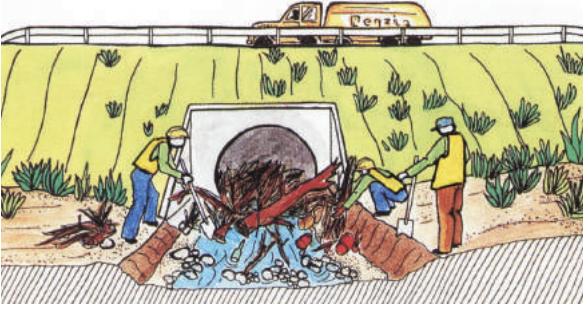

<p><b>Defect 3</b></p>	<p><b>Slope erosion (minor)</b></p>													
<p><b>Development, if neglected</b></p>	<p>On some steep slopes or erodible soils, surface scour may occur if vegetation cover is not established. This could cause damage to the roadway, drainage system or earthworks.</p>													
<p><b>Maintenance Activities</b></p>	<p><b>Plant grass by:</b>  <b>3-01a Seeding</b>  <b>3-01b Turfing (grass sodding)</b></p>													
<p><b>Seeding (3-01a)</b></p>	<p>Grass seeding will only be successful if climate and soil conditions are favourable. Advice can be provided by the local department of agriculture on the best type of grass to be used, fertilizer required and optimal time of planting.</p> <p>Typical procedure:</p> <ul style="list-style-type: none"> <li>▪ Loosen the soil to a depth of 10 cm in the area to be seeded using rakes or similar tools;</li> <li>▪ Drive wooden stakes by roll and column at 30 cm spacing staggered to yield a net spacing of 15 cm;</li> <li>▪ Spread the topsoil to a depth of at least 5 cm;</li> <li>▪ Water the area to be seeded;</li> <li>▪ Apply fertilizer at the specified rate (if necessary);</li> <li>▪ Apply lime at the specified rate and mix in (if necessary);</li> <li>▪ Apply seeds by hand at the specified rate; and</li> <li>▪ Water the area until the grass has taken hold.</li> </ul> <p style="text-align: right;"><b>Stake pattern</b></p> <table style="margin-left: auto; margin-right: auto;"> <tr> <td style="padding: 0 10px;">x</td> <td style="padding: 0 10px;">x</td> <td style="padding: 0 10px;">x</td> <td style="padding: 0 10px;">x</td> </tr> <tr> <td></td> <td style="padding: 0 10px;">x</td> <td style="padding: 0 10px;">x</td> <td style="padding: 0 10px;">x</td> </tr> <tr> <td style="padding: 0 10px;">x</td> <td style="padding: 0 10px;">x</td> <td style="padding: 0 10px;">x</td> <td style="padding: 0 10px;">x</td> </tr> </table>		x	x	x	x		x	x	x	x	x	x	x
x	x	x	x											
	x	x	x											
x	x	x	x											
<p><b>Turfing (grass sodding) (3-01b)</b></p>	<p>This method is suitable when fresh grass sods (soil clumps containing grass and its roots) are available.</p> <p>The general procedure is:</p> <ul style="list-style-type: none"> <li>▪ Prepare the area to be turfed to required levels and slopes;</li> <li>▪ Where no topsoil is present, haul suitable topsoil to site and spread evenly to a depth of not less than 5 cm;</li> <li>▪ Water as required;</li> <li>▪ Cover the area with freshly cut sods without weeds (sods should have thickly matted roots which should not have dried out);</li> <li>▪ Tamp sods with tamper or use hand roller - on slope use stakes to hold sods in position; and</li> <li>▪ Water the sods until the grass takes hold.</li> </ul>													

<p><b>Defect 4</b></p>	<p><b>Culvert or drift silted or obstructed with debris</b></p>	
<p><b>Development, if neglected</b></p>	<p>The intended waterway opening will be so reduced that water cannot flow as intended. Water will back-up or pond on the upstream side of the culvert/ drift and may eventually over-flow the road embankment. The road is then in danger of being washed away.</p> <p>The reduced waterway opening will lead to increased flow rate which may cause scouring or loss of fill material at the inlet.</p>	
<p><b>Maintenance Activities</b></p>	<p><b>4-01 Culvert or drift cleaning</b></p>	
<p>In order to function properly, a culvert must retain the full opening over its complete length. In addition, the upstream approaches and the downstream area must be free of obstructions. Floating debris (tree branches, bushes, etc.) carried by water is a great danger to culverts. The debris may completely block the culvert inlet. The following Routine Maintenance activities may be required:</p> <ul style="list-style-type: none"> <li>▪ Clear any sand, silt or debris from inside the culvert. Sanding or silting of culverts, especially those with openings smaller than 1 metre, can be a particular problem. These culverts can be cleaned by pulling a cable or rope through, to which is attached any suitable object (e.g. a bucket). Alternatively, a long-handled shovel and spike can be used.</li> <li>▪ If the silting problem continues despite regular clearing, it may be necessary to reconstruct the culvert at a higher level or enlarge it.</li> <li>▪ Material and debris from the culvert must be spread or dumped where they cannot cause an obstruction to water flow, preferably on the downstream side of the culvert, well away from the watercourse.</li> <li>▪ Debris should be cleared from drifts and also from the upstream and downstream areas.</li> </ul> <p>This maintenance task is best carried out before the rains and after a heavy rainstorm.</p>		

<p><b>Defect 5</b></p>	<p><b>Drain silted</b></p>	
<p><b>Development, if neglected</b></p>	<p>Concentration of flood flow causing erosion and possible overtopping and damage to roadway, paving or shoulders.</p>	
<p><b>Maintenance Activities</b></p>	<p>The drain may be partially or fully blocked by vegetation growth, bushes, fallen trees, debris, loose silt, loose rocks.</p> <p>Clear the drain of silt by:  <b>5-01 Drain clearing (manual)</b>  <b>5-02 Drain clearing (mechanized)</b></p>	
<p><b>Manual method (5-01)</b></p>	<p>The objective is to remove all soil, high vegetation, materials and objects from the drain which could possibly interfere with free flow of water or cause an eventual blockage of the drain. This can include for example, rocks, silt and sand, weeds, trees, bushes, including their roots, etc. Dispose of these materials well away from the roadside so that water flow will not be impeded, and the material will not wash back into the drain. No soil or debris should be placed on the roadway, unless it is of good quality. On unlined drains a short grass cover can help to stabilize the bottom and sides of the drain. Therefore, where a side drain is established to the correct depth and profile with grass cover and no erosion, it is advisable to merely cut the grass short. This will leave the roots in place to bind the drain surface together.</p> <p>At some locations it may be necessary to reshape, regrade and deepen the drain. It is advisable to adopt a trapezoidal drain shape when using labor methods for road construction. The excavation using a hoe/mattock and shovel is easier for a trapezoidal drain shape than for a V-shaped drain. An added advantage is that the flat invert causes less concentration of water than a V-drain.</p>	 <p><b>Reshaping the drain</b></p>

The following process is followed for reshaping a drain:

- A ditch & slope template should be used to obtain the correct drain shape and slope.
- Using the template, a 50cm wide slot should be excavated to the correct drain shape and slope every 10 metres along the drain. The slots act as a guide for excavating the drain to the correct shape and slope;
- In flat areas, the gradient of the drain should be checked using ranging rods and profiles, or similar methods, to ensure that water will not pond. The levels at adjacent slots should be checked using a line and level or Abney Level, and the level of the slot adjusted if necessary.
- Excavate all surplus material between the slots and to the correct shape with the aid of stringlines stretched between the slots. If necessary, the intermediate invert levels can be checked using a traveler sighted between the ranging rod profiles.
- Material excavated from the drain must be removed and spread well clear of the drain so that it cannot later fall or wash back into the drain.
- The shape and slope of the drain should be checked during excavation using the drain template.

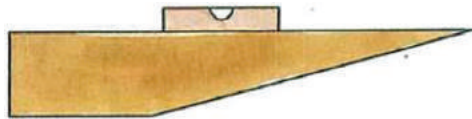

**Ditch and Slope Template**



**A well-shaped drain**

When excavating a completely new drain it is preferable to split the task into two operations:

1. Cut the central rectangular shape to establish the drain invert;
2. Cut the side slopes and check the shape of the drain with the drain & slope template.

The alignment or route of the drain should be set out using string-lines and pegs. Ranging rods and profiles should be set up at the start and outfall of the drain. Intermediate profiles may be required on long drains. The levels of intermediate slots can be determined using the traveler.

The process for setting out a drain is summarized in the sketches below.

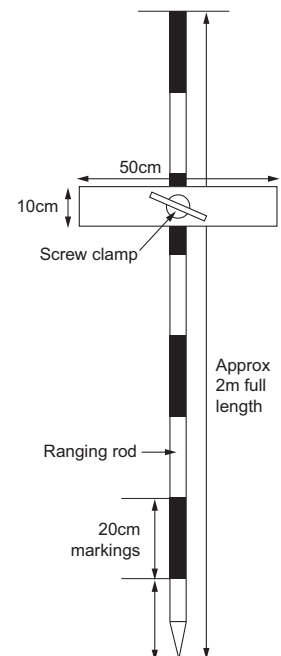

### Setting out a ditch gradient

**STEP 1** Set first and last profiles at 1m above required finished ditch level, intermediate profiles resting on the ground.

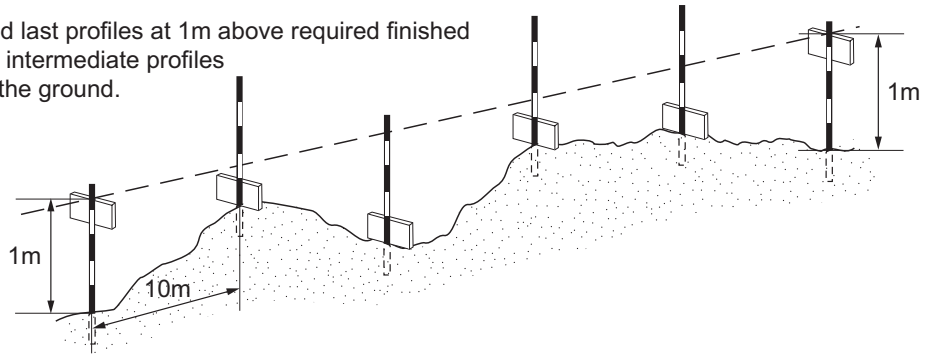

**STEP 2** Raise intermediate profiles to line-of-sight. Check that earthworks are acceptable, if not select other starting points and repeat.

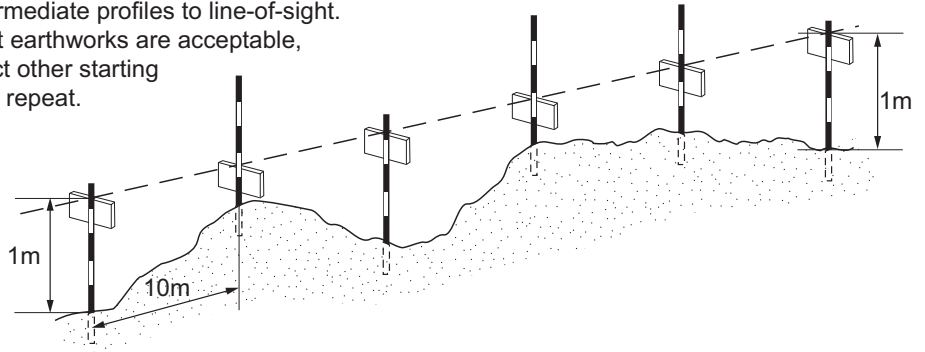

**STEP 2** Place new ditch line pegs at each ranging rod with tops at 1m below the profile boards. This is the finished ditch centre-line level

**Mechanized Method (5-02)**

This activity is recommended where long sections of V-shaped drains are to be maintained and cleaned and where high daily outputs are required. The activity may be carried out by a motor or towed grader. The grader should always work by cutting in the direction of water flow in the drain.

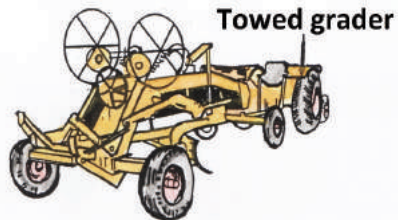

**Towed grader**

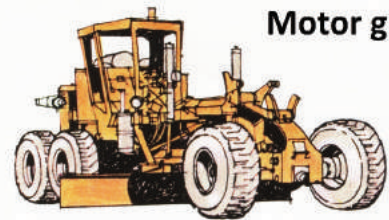

**Motor grader**



**Case 1**

When the grader can operate only on the shoulder and in the drain, but not beyond the drain:

- Start by grading the outside slope of the drain, using the blade to windrow the soil to the bottom of the drain between the rear wheels. (This can be repeated to obtain the desired depth of drain). This part of the task can also be done manually;
- The next blade pass(es) are to clean the invert of the drain by removing the windrow to the top of the drain at road shoulder;
- The final pass is required to move the windrow material away from the shoulder drain edge.
- If the recovered material quality is inferior to that of the road surface, **THE MATERIAL MUST BE REMOVED FROM THE SITE.**

The completed drain should generally have a depth of 50 cm (minimum), which can be checked with a ranging rod and tape measure.

If necessary, the grade of the drain invert can be checked using the methods described in the Manual Method (5-01).

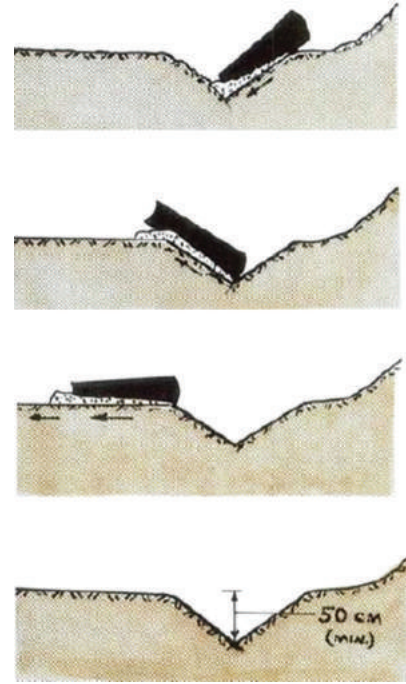

**Procedure for cleaning a side drain**

**Case 2**

When the grader can operate beyond the drain. Reverse the operations shown previously:

- Grade the inside slope, windrowing material to the bottom of the drain - repeat as necessary to achieve the desired depth of drain;
- Remove the windrow material to the top of the outside slope;
- Move windrow away from drain edge and spread the material so that it will not wash back into the drain;
- On completion, the drain should have a depth of 50 cm (minimum), which can be checked with a ranging rod and tape/rule;
- If necessary, the grade of the drain invert can be checked using the methods as described in the Manual Method (5-01).



**The towed grader can be used to clean turn out drains**



<p><b>Defect 6</b></p>	<p><b>Drain eroded (minor)</b></p> 
<p><b>Development, if neglected</b></p>	<p>Damage to drainage system, roadway, structures, paving or shoulders.</p>
<p><b>Maintenance Activity</b></p>	<p><b>6-01 Repair erosion damage (selected fill)</b>  <b>6-02 Construct or replace stone or wooden scour check (check dam)</b>  <b>6-03 Stone masonry lining</b>  <b>6-04 Concrete lining</b></p>
<p><b>Repair erosion damage (selected fill) (6-01)</b></p>	<p>This activity may be sufficient for minor erosion damage to a drain. However, reconstructing the drain profile with selected fill material alone may not be sufficient to prevent the defect recurring within a short time. Loose stones or boulders should be removed. The defective section of drain should be cut back to firm material and fresh material placed in layers not exceeding 15cm thickness and compacted with a hand rammer. If the material is dry it should be sprinkled with water before compaction. The added material should be trimmed back to the correct drain profile and the profile checked with the drain template. Dispose of the excess materials well away from the roadside so that water flow will not be impeded, and the material will not fall or wash back into the drain.</p> <p>If necessary, plant grass on the side slopes and water (4-01, 4-02). Provide check dams (scour checks) (6-02) or drain lining (6-03 and 6-04) to prevent recurrence of the erosion.</p>

**Construct or replace stone or wooden scour check (check dam) (6-02)**

Simple check dams may be constructed of stones or wood. Larger ones may be constructed of stone masonry, brick, gabions or concrete. They reduce the speed and erosion force of the water. They also hold back the silt carried by the water flow to provide a series of gently sloping sections of drain separated by steps.

The check dams must not be too high otherwise water will be forced onto the surrounding ground, the road shoulder or the roadway. The check dam construction should therefore be controlled with the aid of a template.

Check dams should not normally be constructed on drains with gradients of less than 4% otherwise silting of the drain may occur leading to damage to the road. In the case of badly and deeply eroded drains, check dams can be constructed at any gradient to help silt up the eroded sections.



The gradient of the side drain should be checked with an Abney Level or line and level to determine the requirements for scour checks (spacing guidance in the Drainage Design Manual).



After the basic check dam has been constructed, an apron should be built immediately downstream either using stones or grass turves pinned to the drain invert with wooden pegs. The apron will help resist the forces of the water flowing over the check dam. Grass sods should be placed against the upstream face of the check dam to prevent water seeping through the check dam and to encourage the silting behind the check dam. The long-term objective is to establish complete grass cover over the silted check dams to stabilize them.

Well-constructed check dams will allow the water to gently cascade over (and not through) the checks, removing energy from the water and reducing erosion power.

The check dam should be constructed across the full width of the drain to prevent water flowing around the check dam and eroding the road.

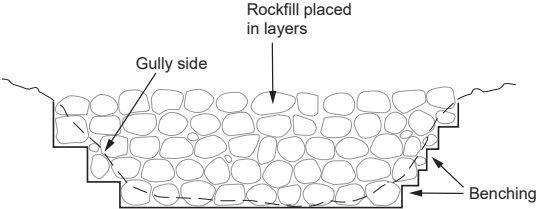

<p><b>Stone masonry lining (6-03)</b></p>	<ul style="list-style-type: none"> <li>▪ The drain is reshaped to the correct cross-section using the ditch template.</li> <li>▪ The stones should be sound, tough and durable, and with a minimum dimension of 200 mm.</li> <li>▪ The stones are cleaned of dirt or clay, moistened and embedded in freshly laid cement mortar composed of one part of cement to six parts of sand.</li> <li>▪ Any spaces between the stones are filled with cement grout of the same composition as the mortar. The grout is worked into the pitching to ensure that all spaces or voids between the stones are completely filled with grout to the full depth of the stone pitching. The mortar and grout are placed in a continuous operation on the same day at any one location</li> <li>▪ Grout spilt onto exposed surfaces of the stone is removed while still soft, and the joints between the stones are neatly finished.</li> <li>▪ The grouted pitching should be cured with wet sacking or other wet cover for a period of not less than four days after grouting.</li> <li>▪ Weep holes should be formed in the stone pitching where there is a high water-table.</li> </ul>	
<p><b>Concrete lining (6-04)</b></p>	<ul style="list-style-type: none"> <li>▪ The drain is reshaped to the correct cross-section using the ditch template.</li> <li>▪ The surface is watered prior to placing the concrete.</li> <li>▪ The concrete should have a minimum strength of 20 MPa.</li> <li>▪ The concrete is laid in alternate panels to the required lines and levels and the remaining panels similarly placed.</li> <li>▪ The thickness of the concrete must conform with the thickness shown on the drawings or specified by the Engineer with a tolerance of <math>\pm 10</math> mm.</li> <li>▪ If mesh reinforcing is specified by the Engineer, it should be placed in the center of the depth of the concrete. Non-porous cover blocks made from cement mortar should be used to ensure accurate positioning of the mesh.</li> <li>▪ The concrete is thoroughly compacted and finished with a wood float.</li> <li>▪ The concrete is cured for at least seven days with wet sacking or other wet cover.</li> </ul>	

<p><b>Defect 7</b></p>	<p><b>Drain eroded (major)</b></p>	
<p><b>Development, if neglected</b></p>	<p>Damage to drainage system, roadway, structures, earthworks, paving or shoulders.</p>	
<p><b>Maintenance Activities</b></p>	<p><b>7-01 Repair erosion damage (rockfill)</b>  <b>7-02 Gabion check dam</b></p> <p>It is important to determine the cause of the erosion so that the repair will minimize the risk of it recurring. It may be necessary to install new drains or culverts to reduce the flow in the drain. The erosion gully may be repaired with rock-fill prior to providing a lining to the drain (7-03 and 7-04). Deep gully erosion can be controlled by constructing check dams using gabions. It is advisable to obtain an Engineer's advice where erosion is extensive.</p>	
<p><b>Repair erosion damage (rockfill) (7-01)</b></p>	<p>Rockfill is constructed using rocks of about 30 cm diameter. Larger rocks, up to 75 cm diameter, can be used if heavy equipment is available for placing the rocks and compacting the layers.</p>	 <p style="text-align: center;"><b>Cross-section through gully</b></p> <p>The bottom of the gully is levelled, and sides are made vertical with benches. The rocks are placed in a single layer in the bottom of the gully and smaller rocks and fine material is driven into the gaps with a hand rammer. The next layers are then placed until the gully is full.</p>
<p><b>Gabion check dam (7-02)</b></p>	<p>Gabions may be used to construct a check dam in an eroded watercourse. Siltation behind the gabions eventually fills the gully and stabilizes the erosion.</p> <p>The procedure for constructing gabions is described below. The top of the gabion wall should be shaped to contain the flow of water.</p> <p>A filter fabric can be placed behind the gabion to prevent fine material from being washed through the gabion.</p>	



### Gabion Construction

Gabions are usually made of zinc or plastic-coated steel wire baskets, although they may also be made from welded mesh sheets or galvanized chainlink fencing. The baskets are hand-filled with rock and stones between 12 cm and 30 cm size.

Where a gabion box is required to be replaced or added, the procedure for building a new gabion box should be used as follows:

- Foundations should be excavated level and cleaned as for a conventional structure, with any unsuitable material removed and replaced with good soil, stone or gravel, and compacted.
- The gabion baskets are normally supplied folded flat complete with tying wire so that the transport volume is minimised. Cages should be woven together using 3 mm binding wire securing all edges every 15 cm with a double loop. The binding wire should be drawn tight with a pair of heavy-duty pliers and secured with multiple twists. The baskets should be erected in their final position.
- The center gabion only should be filled initially to act as an anchorage. The connected baskets should be stretched and staked with wires and pegs to achieve the required shape. Filling should be carried out by hand using hard durable stones not larger than 250 mm and not smaller than the size of the mesh.
- The stones should be tightly packed by hand with a minimum of voids. The stones should not be dumped into the baskets by machine. Boxes of 1 metre height should be filled to 1/3 height. Horizontal bracing wires should then be fitted and tensioned with a windlass to keep the vertical faces even and free of bulges. Further bracing should be fixed after filling to 2/3 height. 500 mm height boxes should be braced at mid height only. 250mm or 330 mm deep gabions do not require internal bracing.
- The stones should be carefully packed to about 3 to 5 cm above the top of the box walls to allow for settlement. Smaller material can be used to fill the voids on the top face, but excessive use of small stones should be avoided.
- The lids are closed and stretched tightly over the stones, (carefully) using crowbars if necessary. The corners should be temporarily secured to ensure that the mesh covers the whole area of the box. The lid should then be securely woven to the tops of the walls, removing stones if necessary to prevent the lid from being overstretched.

The procedure for assembling the gabion cages is illustrated below.

**Stones must be larger than the mesh size**



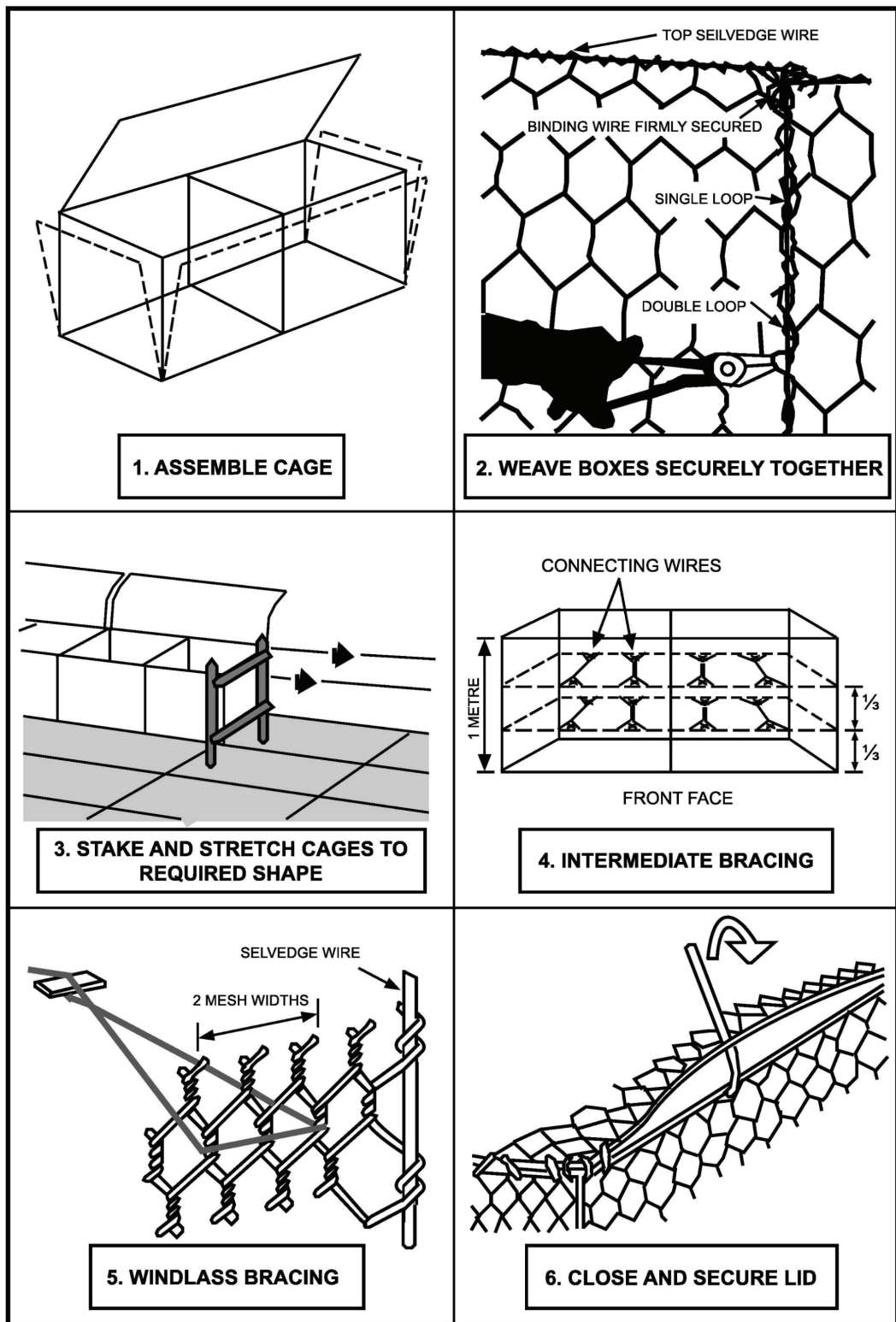



Procedure for tying gabion baskets

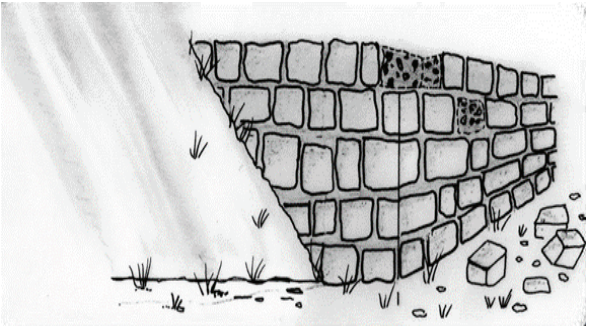

<p><b>Defect 8</b></p>	<p><b>Gabion structure damaged</b></p> 
<p><b>Development, if neglected</b></p>	<p>Further damage to structure or roadway, slope or structural failure.</p>
<p><b>Maintenance Activities</b></p>	<p><b>8-01 Gabion structure repair</b></p> <p>Gabions have great stability but allow minor settlement. Repairs may be required due to bulging or breaking of the basket due to excessive foundation or backing movement, or settlement of the stones within the basket.</p>
<p><b>Gabion structure repair (8-01)</b></p>	<p>Repairs to gabions should aim to ensure that the stone continues to be contained. Repairs will normally consist of opening the baskets, re-packing the stone inside, topping up stone if necessary and re-securing the lid of the gabion. It may be necessary to weave new cage material over broken or deformed areas. Any suitable galvanized steel mesh or woven sheets can be used for this.</p>

<b>Defect 9</b>	<p><b>Mortared masonry damaged</b></p> 
<b>Development, if neglected</b>	Further damage to structure or roadway, slope or structural failure.
<b>Maintenance Activities</b>	<b>9-01 Mortared masonry repair</b>
<p>This activity should only be carried out on masonry structures in reasonably good condition. It is recommended that the structure be completely rebuilt if it is in danger of collapse.</p> <ul style="list-style-type: none"> <li>▪ Clean and rake out defective joints of weak mortar, soil and vegetation using compressed air or a water spray, hammer and chisel;</li> <li>▪ At locations where the joint has to be completely renewed, the stone or brick should be eased out of place temporarily until a new mortar bed is placed;</li> <li>▪ Replace missing stones with sound pieces;</li> <li>▪ Use templates and stringlines to ensure the correct shape and incline of the face of the mortared masonry work;</li> <li>▪ Dampen the joint surfaces where fresh mortar has to be applied;</li> <li>▪ Mix a mortar of cement and sand as required or specified (normally 1 cement: 4 sand) and add only enough water to permit mortar to be well mixed and applied;</li> <li>▪ Apply fresh mortar to joint, filling all space available, compacting with a suitable wooden rammer. Do not use mortar which has fallen on the ground;</li> <li>▪ Smooth joints with a suitable tool (a piece of rubber or plastic water hose, or bent reinforcing steel);</li> <li>▪ The final mortar surface should be inset slightly from the stone/brick surface to achieve a tidy finish;</li> <li>▪ In dry or windy weather conditions, mortar can dry out too quickly. Prevent this by sprinkling water on joints after the mortar has set and until mortar has completely hardened. Alternatively cover the work area with wet jute sacks or similar material;</li> <li>▪ Clean visible stone or brick surfaces which have been stained by mortar or cement-water in the process of the work so that the finished work will present a neat appearance; and</li> <li>▪ Remove surplus materials and leave the site in a clean and tidy condition.</li> </ul>	

<p><b>Defect 10</b></p>	<p><b>Dry masonry damaged</b></p>	
<p><b>Development, if neglected</b></p>	<p>Further damage to structure or roadway, slope or structural failure.</p>	
<p><b>Maintenance Activities</b></p>	<p><b>10-01 Dry masonry repair</b></p>	
<p>This activity should only be carried out on dry masonry structures in reasonably good condition. It is recommended that the structure shall be reconstructed if it has settled or is in danger of collapse.</p> <p>Where possible use the established local dry-stone construction techniques and skills..</p> <ul style="list-style-type: none"> <li>▪ Carefully take down the defective areas of dry-stone masonry, stacking the stone for re-use;</li> <li>▪ Clean and rake out defective joints of soil and vegetation using hammer and chisel, and brush;</li> <li>▪ Re-build the dry-stone work using the salvaged stones and carefully selecting each stone to ensure good bonding horizontally and through the width of the stonework. Use smaller stones to wedge the larger ones where necessary;</li> <li>▪ Add new stones if necessary;</li> <li>▪ Use templates and stringlines to ensure the correct shape and incline of the face of the dry masonry work;</li> <li>▪ Pack the spaces between stones with soil or gravel;</li> <li>▪ Weak areas or cappings may need to be strengthened with mortar jointing; and</li> <li>▪ Remove surplus materials and leave the site in a clean and tidy condition.</li> </ul>		
		

<b>Defect 11</b>	<b>Road sign dirty or defective</b>	
<b>Development, if neglected</b>	<p>Road users do not benefit from the warning or information intended by the road sign.</p> <p>This is a safety issue and could lead to accidents if not corrected.</p>	
<b>Maintenance Activities</b>	<p><b>11-01 Clean road sign</b></p> <p><b>11-02 Replace road sign</b></p>	
<b>Clean road sign (11-01)</b>	<p>Clean dirty sign including removal of dirt and dust.</p>	
<b>Replace road sign (11-02)</b>	<p>It may be more cost-effective to replace the sign and post. The sign and post should be supplied and installed according to the standard specifications.</p>	

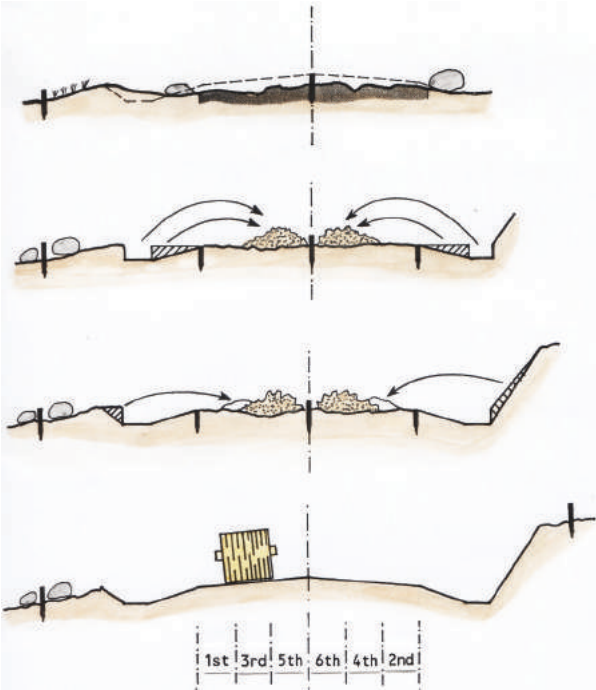
<p><b>Defect 12</b></p>	<p><b>Road surface potholed, rutted or uneven, and does not drain to shoulder</b></p>	
<p><b>Development, if neglected</b></p>	<p>Road becomes waterlogged or impassable.</p>	
<p><b>Maintenance Activities</b></p>	<p><b>12-01 Reshape &amp; compact earth road camber (labor-based)</b>  <b>12-02 Reshape &amp; compact earth road camber (equipment-based)</b></p>	
<p><b>Reshape &amp; compact earth road camber (labor based) (12-01)</b></p>	<p>This activity is carried out using labor, basic hand tools and control aids.</p> <p>The method comprises the following steps:</p> <ul style="list-style-type: none"> <li>▪ Setting out;</li> <li>▪ Excavation of drain and slope;</li> <li>▪ Excavation of backslope; and</li> <li>▪ Camber formation and final compaction.</li> </ul>	 <p style="text-align: center;"><b>Reshaping a road using the labor-based method</b></p>
<p><b>Setting out the center-line</b></p> <ul style="list-style-type: none"> <li>▪ The profile method of setting out enables a smooth vertical alignment to be re-established on a severely deteriorated road surface;</li> <li>▪ The alignment will consist of straight gradients and vertical curves;</li> <li>▪ The center line of the road is pegged every 10 metres; and</li> <li>▪ A ranging rod is fixed at each 10 metre peg.</li> </ul> <p>Each ranging rod is fitted with a profile board. The profile board can slide up and down the ranging rod and be clamped at any height.</p>		

### Setting out a gradient

Setting out is arranged in sections of 60 to 100 metres, which approximate to either a straight gradient or vertical curve on the road line.

Check that the quantity of earthworks at each center line (finished level) peg is reasonable, or repeat the procedure using different start and end points.

The procedure for setting out a gradient is summarized below.

- STEP 1** Set first and last profiles at 1m above required finished road level, intermediate profiles resting on ground.

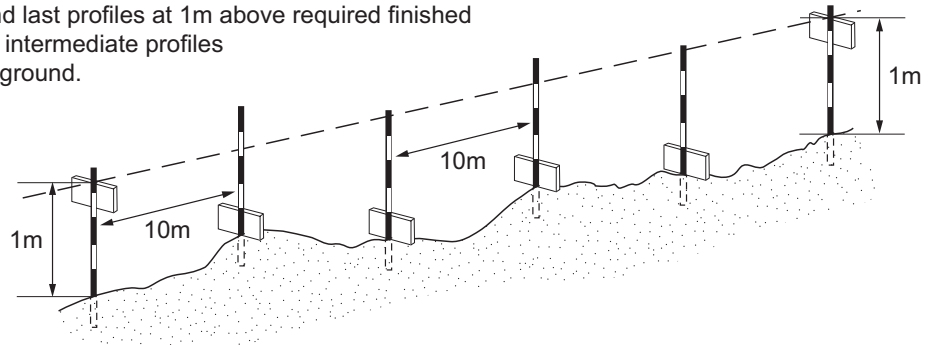

- STEP 2** Raise intermediate profiles to line-of-sight. Check that earthworks are acceptable, if not select other starting points and repeat.

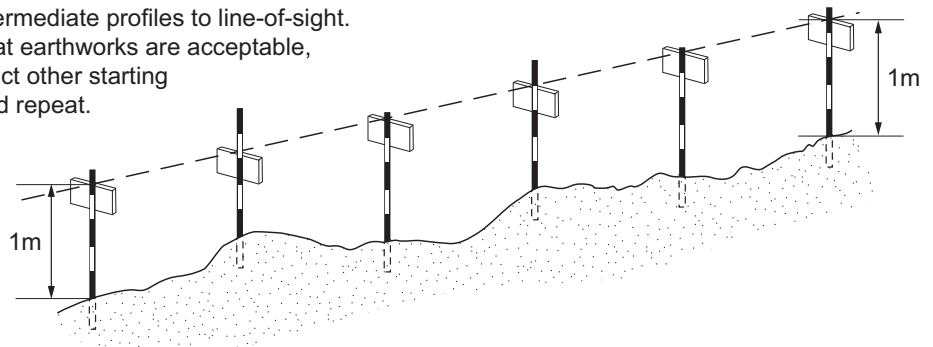

- STEP 3** Place new centre line pegs at each ranging rod with tops at 1m below the profile boards. This is the finished road centre-line level.

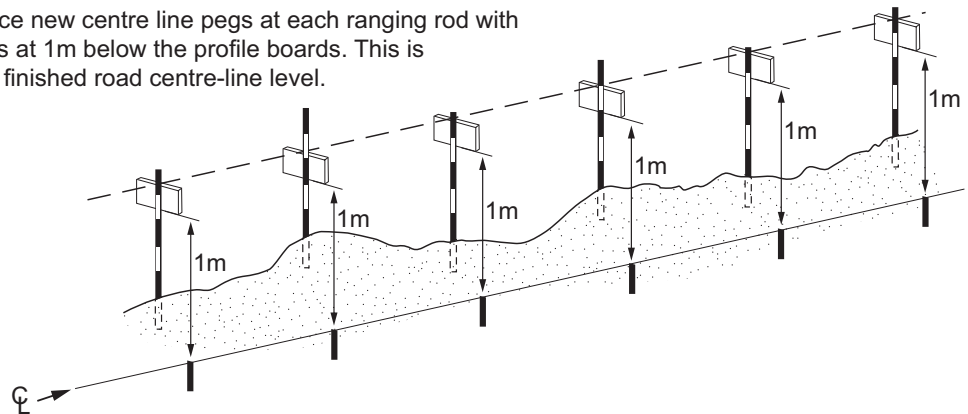



**Setting out a vertical curve**

The length of a vertical curve depends on the design speed of the road (see Part A Section 5.7). Profile boards are placed at 10m spacings from the start to the end of the curve and the height of each profile adjusted to give a smooth curve.

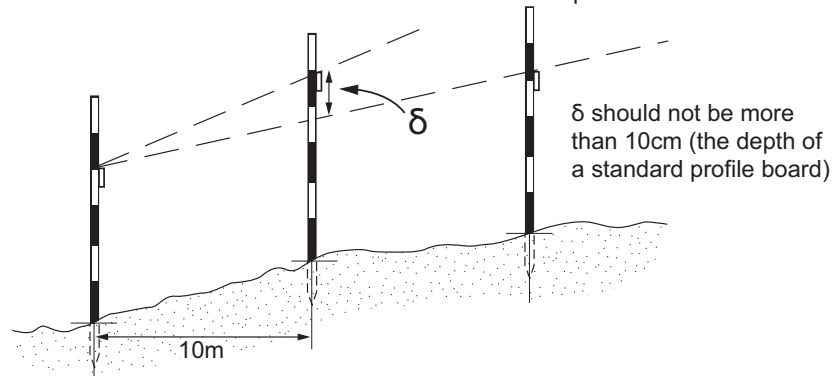
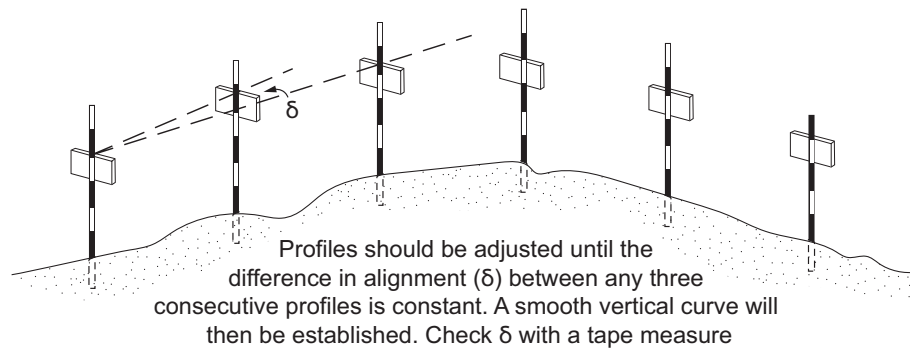

When the curve is acceptable, place new centre-line pegs at each ranging rod with tops at 1m below the profile boards. This is the finished road centre-line level

**Setting out the cross-section**

Once the center line level pegs are fixed, set out the pegs for the edge of the roadway and both sides of the drain using the tape measure, camber board and spirit level for the required road cross section.

Pegs should be driven in to the ground to mark the required finished cross section level, or a fixed height above.

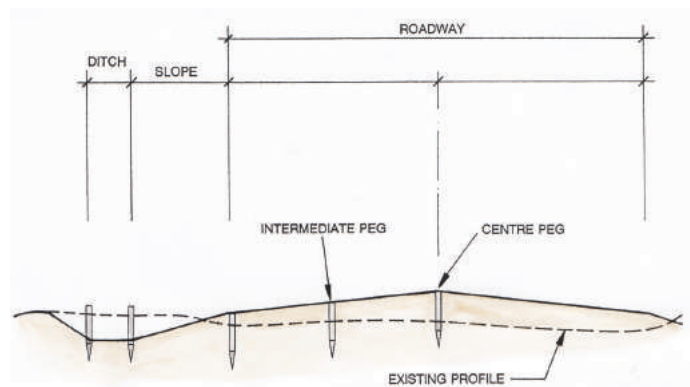

### Excavate drain and slope

- Material is excavated from the drain and slope area and used to form the camber until the required shape of drain and slope is achieved;
- Check shape with the drain and slope template, and spirit level;
- If too much material is excavated, discard the surplus material well beyond the side drain;
- If the filling placed is greater than 15 cm deep, then it is preferable to spread the fill material with rakes and compact it in 15-20 cm layers;

If insufficient material is excavated to form the camber, dig additional material from the backslope or from beyond the side drain.



Ditch and slope template

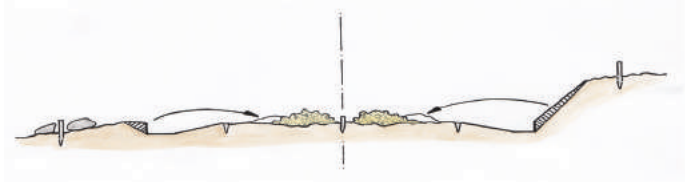

Obtaining additional material from the backslope

### Camber formation and final compaction

- Continue adding material to the camber to achieve the required profile after compaction;
- Stringlines stretched directly and diagonally across the running surface between the setting out pegs can be used to check the camber shape;
- In dry conditions add water to moisten the material to help compaction;
- Compact the fill material to the final profile, preferably using a hand or animal drawn roller;
- If a roller is not available, use hand rammers or the tires of any vehicle to uniformly compact the soil across the roadway width.

The shaped and compacted earth road surface is a suitable foundation on which one of the surface options can be constructed directly, with any necessary base or sub-base depending on the strength of the soil.



Camber formation



Compaction

**Reshape & compact earth road camber (equipment-based) (12-02)**

Heavy grading may be carried out with a motor grader or a tractor towed grader. The task requires towed or self-propelled watering and compaction equipment. A machine attendant should be employed to direct traffic and grader turning and to remove large stones and other unwanted material from the path of, or behind, the grader.

**Preparation**

Patching of large potholes or depressions (Activity 13-01) should be carried out in advance of the grading. Areas of standing water should be drained. This preparation will ease the work and make the resulting surface last longer.

**Equipment**

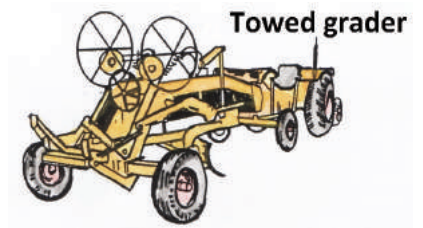
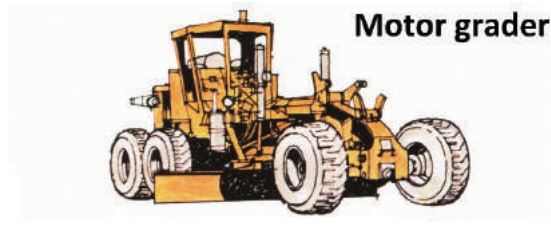

**Scarifying**

Using a motor or tractor towed grader it may be necessary to scarify the existing surface to cut to the bottom of any surface defects and loosen the material for reshaping.

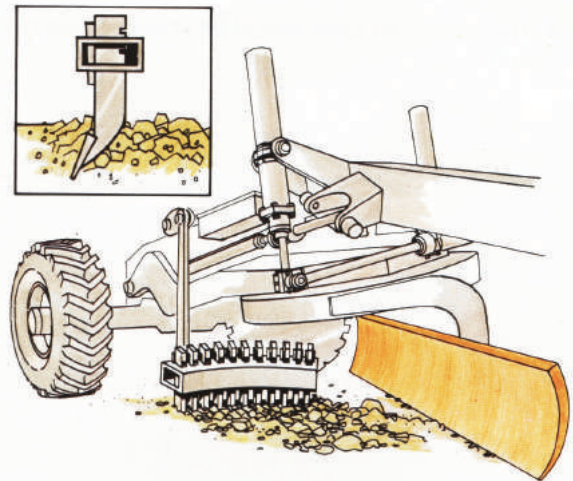

**Grading**

The grader works on one side of the road at a time and works in passes about 200 metres long to convenient and safe turning points. Heavy Grading will require additional passes to achieve the required camber. Work should be completed on one side of the road at a time. An even number of passes should be used to avoid a flat finished crown. Normally initial cutting passes are required to bring material in from the edges of the road. Spreading passes redistribute the material away from the crown. The initial passes cut to the bottom of the surface irregularity and deposit a windrow just beyond the center line.

The procedure is shown in the illustration below.

**Watering**

The towed or self-propelled water tanker sprays the windrow with water (if the material is dry). The windrow is spread back across the road depositing all the material to give the correct camber. A second application of water may be required to obtain the correct moisture content for compaction.

**Self propelled water bowser**

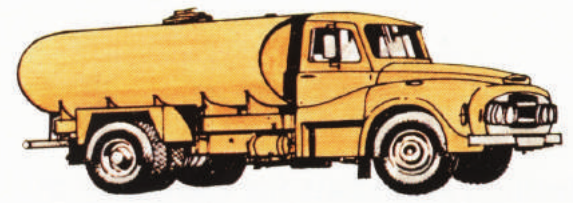

### Grading procedure

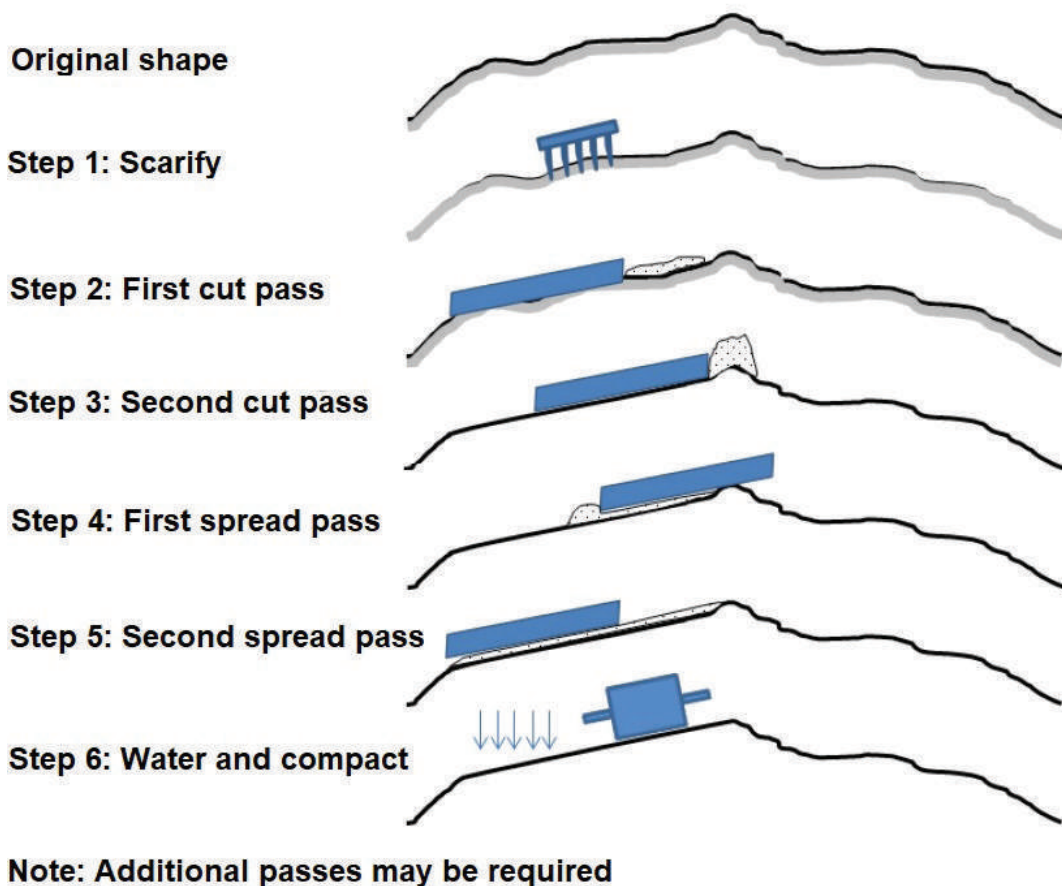

### Cambering

The aim should be to develop a proper crown on the road. The road should be cambered to fall away from the crown at a rate of about 6 to 7 cm for each metre from the center of the road before compaction. This should achieve a crossfall of about 4 to 6 cm per metre (4 to 6%) after compaction.

If there is insufficient camber, water will not drain easily from the surface of the road, potholes will form, and the road will deteriorate quickly. This is particularly important on gradients, where the rain water tends to run along the road forming erosion channels.

Do not make a final pass down the center of the road with the grader blade horizontal. This flattens the center of the road and causes water to pond leading to rapid deterioration of the surface. Do not leave a windrow on the road overnight as this is a danger to traffic.

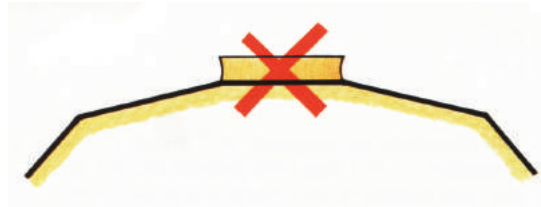

### Compaction

When towed, self-propelled compaction plant is being used, it must follow close behind the grader, but only on sections where grading has been completed. Usually about eight passes of a roller of five to ten tons is needed to achieve full compaction, working towards the center of the road. Shoulders are treated as part of the running surface.

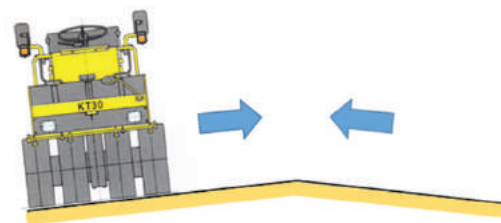



**Check the camber**

Camber should be checked with a camber board at about 100 metre intervals along the road.

To use the camber board, place it on its edge across the road with the shorter end pointing towards the centre line. Check the level bubble. If it is central, the camber is correct. If it is not central, the camber is either too steep or too flat and further grading and compaction are required.

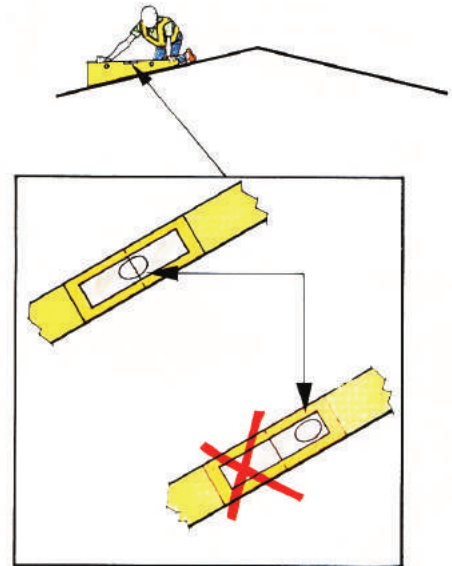

**Structures**

The shape of the road must be maintained over culverts to avoid a dangerous hump. Material should be brought in if necessary from either side of the culvert to achieve a safe vertical alignment and maintain a cover to the top of the culvert of at least 3/4 culvert diameter.

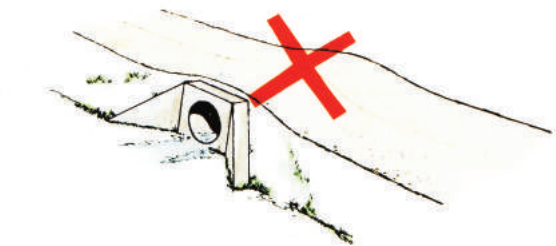

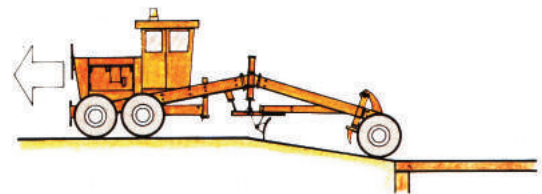
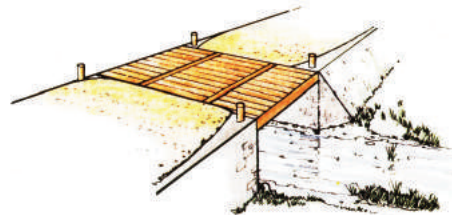

Bridge decks should be kept free from gravel. Loose material should be swept away by the grader attendants. It is important to have smooth approaches to the bridge. They should be smoothed out using the back of the blade with the grader working in reverse, or by hand.



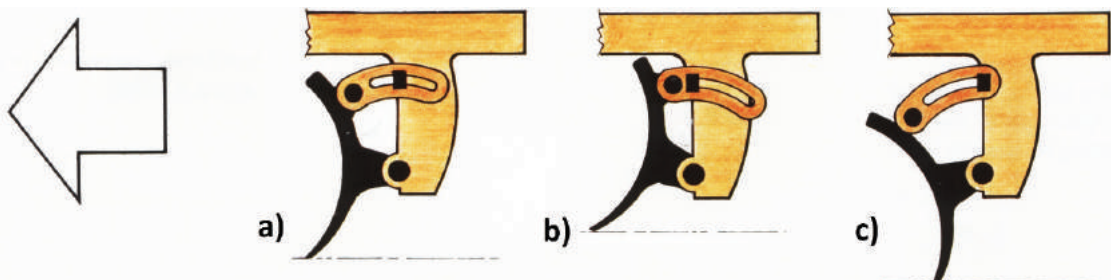

**Blade position**

- a. For most grading work, the cutting blade is set to be vertical
- b. For cutting hard surfaces, the cutting blade should be set back at the top to give the most effective cutting angle. Scarifying passes should also be made before cutting.
- c. For spreading, the cutting blade should be set forward at the top.

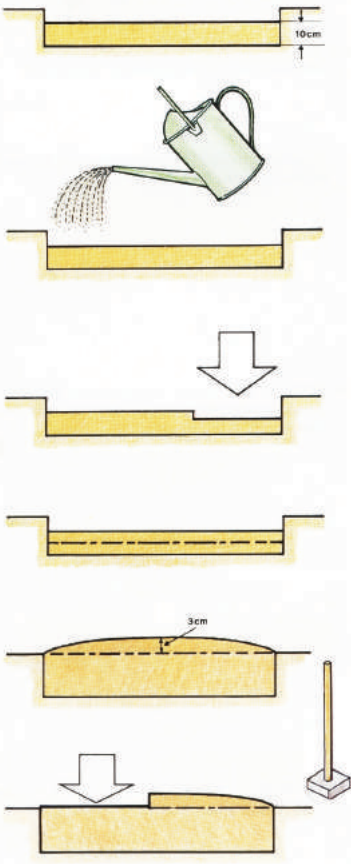

<p><b>Defect 13</b></p>	<p><b>Road surface potholed and/or with erosion gullies</b></p>		
<p><b>Development, if neglected</b></p>	<p>Gravel surface loss increases. Road becomes very rough, slowing and damaging traffic, and may become waterlogged or impassable.</p>		
<p><b>Maintenance Activities</b></p>	<p><b>13-01 Spot repair with selected material</b></p>		
<p>Potholes and ruts should be repaired using selected gravel material meeting the national specification for gravel wearing course. The procedure is as follows:</p> <p>Loose material and standing water are brushed from the pothole or rut to be patched;</p> <ul style="list-style-type: none"> <li>▪ Loose material and standing water are brushed from the pothole or rut to be patched;</li> <li>▪ The sides of the potholes and ruts should be cut back to be vertical and to reach sound material;</li> <li>▪ The moisture content of the imported material can be checked quickly by squeezing it in the hand. If the material is wet enough to stick together, it is suitable for use. If water runs out of the material, it is too wet and should not be used;</li> <li>▪ If the material is dry, the area to be patched should be sprinkled with water and water should also be added to the patching material.</li> <li>▪ The area is filled with gravel to a depth of about 10 centimeters;</li> <li>▪ If the material is dry, it should be sprinkled with water to help compaction;</li> <li>▪ The layer is then compacted using the roller or hand rammer (in this way the thickness of the patch is built up in layers);</li> <li>▪ Finally, the patched area is filled evenly with the gravel to approximately 3 cm above the level of the surface and is spread and raked to the correct shape;</li> <li>▪ The patch is then compacted using the roller or hand rammer to give a surface which is only slightly above the level of the surrounding road to allow for further traffic consolidation;</li> <li>▪ Both large or small areas to be patched are repaired in the same way, the rammer is used for the smaller potholes. The roller is used for larger areas, although the hand rammers will still be required for the corners and short edges;</li> <li>▪ Patching work started must not be left unfinished overnight. At night the site should be made safe for traffic and all signs and obstacles removed from the road.</li> </ul>			

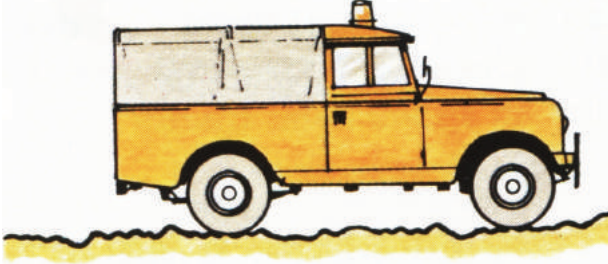



<p><b>Defect 14</b></p>	<p><b>Road surface potholed, rutted or uneven, and does not drain to shoulder (minor)</b></p> 
<p><b>Development, if neglected</b></p>	<p>Ride quality reduces resulting to slow traffic movement, increased wear and tear on vehicles and increased traveling cost for road users.</p>
<p><b>Maintenance Activities</b></p>	<p>Light grading may be carried out with a motor grader or a tractor towed grader to correct minor defects on the gravel road surface such as corrugations, shallow ruts and flat camber. The task may also be achieved using labor with hand tools.</p> <p><b>14-01 Light reshaping, manual method</b>  <b>14-02 Light reshaping, mechanized method</b></p> <p>Potholes and ruts in the carriageway should be filled before light reshaping as described under Activity 13.</p>
<p><b>Light reshaping, manual method (14-01)</b></p>	<ul style="list-style-type: none"> <li>▪ The surface material may be loosened, trimmed and reshaped with a pickaxe, hoe or mattock and rakes to form the required camber and crossfall;</li> <li>▪ The shape is checked with the camber board and spirit level;</li> <li>▪ If gravel stockpiles are provided, any local depressions are filled with material transported in a wheelbarrow, or other carrying device; and</li> <li>▪ Pegs and string lines should be used to help to achieve the correct shape and camber.</li> </ul> <p>The reshaping should be carried out immediately after the rains when the material is damp. Compaction is achieved by vehicles using the road.</p> <div style="display: flex; justify-content: space-around;"> <div data-bbox="1021 902 1468 1243">  <p style="text-align: center;"><b>Light reshaping by hand</b></p> </div> <div data-bbox="1021 1310 1468 1624">  <p style="text-align: center;"><b>Checking the camber</b></p> </div> </div>

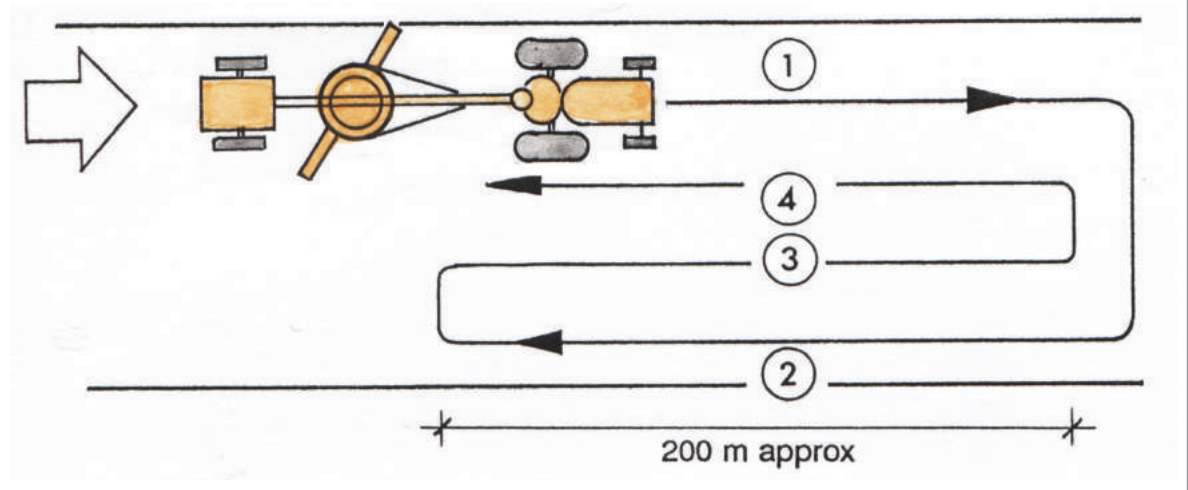

**Light reshaping, mechanized method (14-02)**

The motor grader or tractor towed grader is used to draw the surface material back to the crown of the roadway. Normally only four passes will be required to achieve this minor reshaping. It is best carried out immediately after the rains when there is sufficient moisture in the material for reconsolidation under traffic, so that expensive watering and compaction operations are not required.

The four passes are shown in the illustration below.

**Light reshaping**

<p><b>Defect 15</b></p>	<p><b>Road surface rutted or uneven with potholes, and does not drain to shoulder (major)</b></p>	
<p><b>Development, if neglected</b></p>	<p>Road becomes very rough resulting in slow and damaging traffic movement. Water ponds on the road surface and seeps through onto the subgrade layer. Gravel surface loss increases, and subgrade strength reduces. Vehicle wheels may eventually punch through the surface into the subgrade making the road difficult to ply or impassable.</p>	
<p><b>Maintenance Activities</b></p>	<p><b>15-01 Blade gravel road (heavy)</b></p> <p>Heavy grading may be carried out with a motor grader or a tractor towed grader. The task requires a towed or self-propelled watering and compaction equipment.</p> <p>The procedure for grading is described under Defect 12 Activity 12.02.</p>	

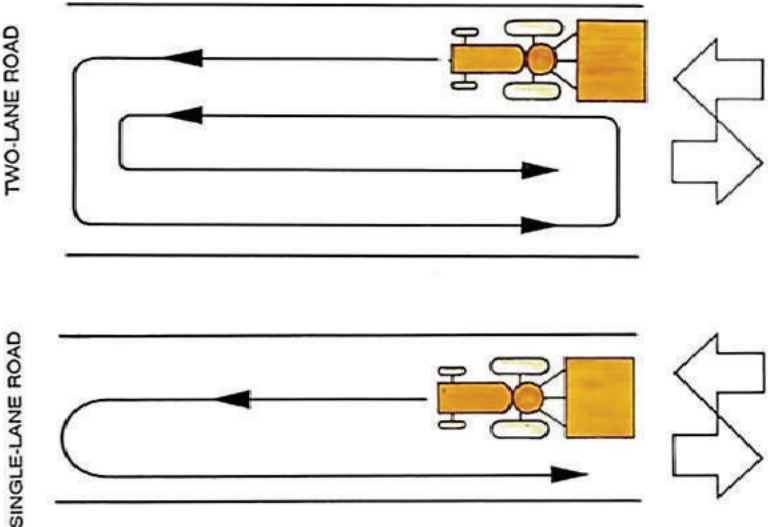
<p><b>Defect 16</b></p>	<p><b>Road surface starting to corrugate</b></p>	
<p><b>Development, if neglected</b></p>	<p>Road surface becomes very rough, slowing traffic movement, increasing chances of skidding, and damaging vehicles. Major reshaping is then required.</p>	
<p><b>Tire dragging (16-01)</b></p>	<p>Minor corrugations can be dealt with by using a low cost drag towed by a tractor or other vehicle.</p> <p>Drags can be made from old tires or various arrangements of discarded steel sections.</p> <p>Tire dragging should be carried out as a routine preventative activity as it slows down the development of corrugations. If the corrugations have already formed, it might be too late for dragging and reshaping with a grader might be required.</p>	
 <p style="text-align: center;"><b>Tire drag</b></p>	 <p style="text-align: center;"><b>Towing the drag</b></p>	
 <p style="text-align: center;"><b>Tire dragging sequence</b></p>		



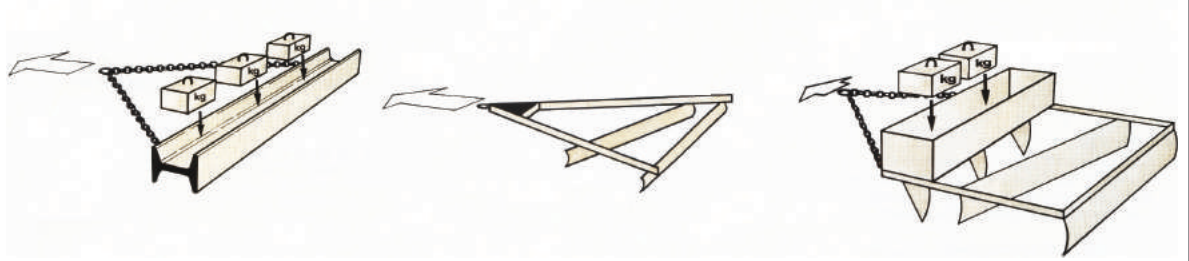

- The tractor tows the drag at up to 5 km/hour depending on the type of drag and on the type and condition of the road surface;
- The length of pass should be as long as possible;
- The number of passes needed will depend upon the conditions and the width of the road;
- The equipment should work in the same direction as the traffic flow.

DO NOT drive too fast or the drag will jump over the surface irregularities and raise a lot of dust and will also cause a hazard to traffic.





**Different types of drag**

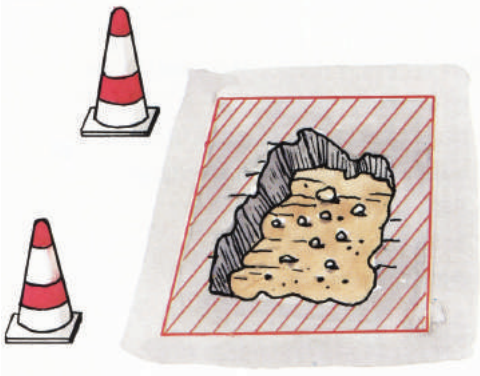
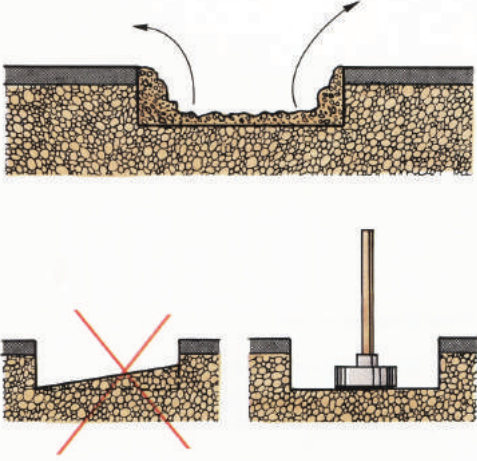

<p><b>Defect 17</b></p>	<p><b>Paved road pothole or surface defect</b></p>	
<p><b>Development, if neglected</b></p>	<p>The road becomes very rough, slowing and damaging vehicles and increasing risk of accidents. Water ponds on the road surface, soaking into the pavement layers and speeding the deterioration. Road user costs increase substantially. The road may become impassable.</p>	
<p><b>Maintenance Activities</b></p>	<p>Depending on the type of paved road surface:</p> <p><b>17-01 Pothole or spot repair (sealed road)</b>  <b>17-02 Pothole or spot repair (unmortared stone or brick)</b>  <b>17-03 Pothole or spot repair (mortared stone or brick)</b>  <b>17-04 Repair to edge break (sealed road)</b>  <b>17-05 Crack sealing</b></p>	
<p><b>Types of defects</b></p>	<p>Paved roads should give many years of trouble-free service, but from time to time defects can be expected to develop in any surface. Defects may include:</p> <ul style="list-style-type: none"> <li>▪ Potholes;</li> <li>▪ Edge break; and</li> <li>▪ Cracks.</li> </ul>	
 <p style="text-align: center;"><b>Pothole</b></p>	 <p style="text-align: center;"><b>Edge break</b></p>	 <p style="text-align: center;"><b>Cracking</b></p>

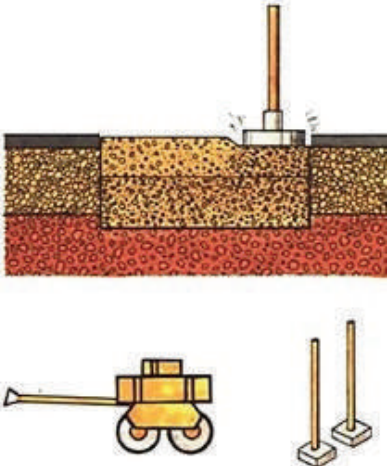
<p><b>17-01 to 17-03 Pothole or spot repair</b></p>	<p>Surfacing defects are normally limited in extent and can be repaired using labor, hand tools (pick, shovel and hand rammer) and suitable materials. Normally only light compaction equipment is required. Signs must be placed either side of the area under repairs to warn road users and for the safety of those carrying out the work.</p> <p>For all paved road surface types, the repair techniques are similar, and consist of:</p> <ul style="list-style-type: none"> <li>▪ Mark out the area to be repaired;</li> <li>▪ Excavate the area to be repaired to a minimum depth of 5cm below the road surface;</li> <li>▪ Brush and clean the bottom surface of the hole;</li> <li>▪ Backfill the hole with new material and compact;</li> <li>▪ Reinststate the surfacing.</li> </ul>
<p><b>Marking out the area to be repaired</b></p>	<p>The area to be treated is marked out with paint or chalk by drawing a rectangle around the defects.</p> 
<p><b>Excavation of the area to be repaired</b></p>	<ul style="list-style-type: none"> <li>▪ Remove all loose or damaged material from within the marked-out area of the road surface back to a firm, sound material. Sledgehammers, crowbars, hammers and chisels may be required.</li> <li>▪ Increase the depth of the hole until firm, dry material is found and then trim the walls of the hole so that they are vertical. If water or excessive moisture is present, then arrangements must be made to drain it away from the pavement foundation.</li> <li>▪ Trim the bottom of the hole such that it is flat, horizontal and free from loose material then compact it with a hand rammer.</li> <li>▪ Trim the walls of the excavation so that it is vertical and free from loose material</li> </ul> 

<p><b>Backfilling the hole with new material</b></p>	<p>The hole is filled with a selected material resembling as closely as possible the existing base. The material is placed in the hole and compacted in one or more layers of regular thickness depending on the depth and materials involved. The maximum layer thickness should be 100 mm.</p> <p>Generally, the last layer, prior to compaction, must have an excess thickness of about 1/5 the depth of the final layer, in order to allow for settlement on compaction.</p> <p>Compaction is continued depending on the size of the excavation, using the vibrating roller, plate compactor or with a hand rammer, until the surface is level with the top of the base layer to allow for placement of the surface layer.</p> 
<p><b>Reinstatement of the surfacing</b></p>	<p>After the hole has been repaired, the surface is reinstated using materials similar to those used in the original construction of the road. The finished level should match the adjoining pavement levels.</p>
<p><b>17-04 Edge break repair</b></p>	<ul style="list-style-type: none"> <li>▪ Signs must be placed either side of the area under repairs to warn road users and for the safety of those carrying out the work.</li> <li>▪ Mark the area to be repaired using a chalk line to ensure a straight edge is achieved.</li> <li>▪ Break back the edge of the surfacing to the marked line. Sledgehammers, crowbars, hammers and chisels may be required.</li> <li>▪ Remove the loose material and discard it at designated locations.</li> <li>▪ Reinstatement the edge of the road using pre-mix asphalt (cold or hot). Compact the asphalt using hand rammers, a plate compactor or pedestrian roller.</li> </ul> <p>The shoulder of the road should be reshaped, compacted and regravelled if the gravel shoulder of the road has become eroded and there is a drop-off from the carriageway to the shoulder of more than 5cm. Regravelling should be carried out in accordance with the remedy for Defect 19.</p>
<p><b>17-05 Crack sealing</b></p>	<p>If cracks in the surfacing are not sealed, they allow water to enter the road pavement and cause the pavement material and the subgrade to soften. This results in the formation of potholes and other defects. The following procedure is carried out for sealing cracks:</p> <ul style="list-style-type: none"> <li>▪ Signs must be placed either side of the area under repairs to warn road users and for the safety of those carrying out the work;</li> <li>▪ Clean out the cracks with a broom and air from a tire pump or compressor;</li> <li>▪ Fill the cracks with an approved cut-back bitumen or bitumen emulsion. For wider cracks mix fine sand into the binder;</li> <li>▪ Pour the liquid into the crack using a watering can and push the liquid into the crack using a squeegee shaped into a vee;</li> <li>▪ Sprinkle the surface of the binder with dry sand or quarry dust; and</li> <li>▪ Remove traffic control signs and safety devices and reopen the road to traffic.</li> </ul>

<p><b>Defect 18</b></p>	<p><b>Shoulder uneven and does not drain water away from roadway</b></p> 
<p><b>Development, if neglected</b></p>	<ul style="list-style-type: none"> <li>▪ Hazard to road users, increased risk of accidents;</li> <li>▪ Obstruction of water flow off the roadway;</li> <li>▪ Water collects and softens/weakens the shoulder and adjoining pavement;</li> <li>▪ The edge of the pavement will break when vehicle wheels run over it.</li> </ul>
<p><b>Maintenance Activities</b></p>	<p><b>18-01 Shoulder grading (mechanized)</b></p>
<p><b>Shoulder grading (mechanized) (18-01)</b></p>	<p>This routine maintenance activity may be carried out if no additional material is required to be added to the shoulder. The shoulder material should contain sufficient moisture to enable the reshaped material to be compacted by the grading equipment or a roller. It is therefore ideally carried out during the rains. Otherwise, water should be added to ensure a more durable surface finish.</p>

<p><b>Defect 19</b></p>	<p><b>Shoulder uneven and eroded with edge drop</b></p> 
<p><b>Development, if neglected</b></p>	<ul style="list-style-type: none"> <li>▪ Hazard to road users, increased risk of accidents;</li> <li>▪ Inadequate support for the road pavement and surface;</li> <li>▪ The edge of the pavement will break when vehicle wheels run over it;</li> <li>▪ The roadside drain may become blocked by the excess material.</li> </ul>
<p><b>Maintenance Activities</b></p>	<p><b>19-01 Shoulder rehabilitation (manual)</b>  <b>19-02 Shoulder rehabilitation (mechanized)</b></p>
<p><b>Shoulder rehabilitation manual method (19-01)</b></p>	<p>The procedure is as follows:</p> <ul style="list-style-type: none"> <li>▪ The low surfaces and all high material are loosened with a pick axe.</li> <li>▪ The shoulder is reshaped to slightly above the final level and the correct crossfall using a shovel and rake. Any low spots are topped up with fresh material of the same type and quality as the existing shoulder.</li> <li>▪ The crossfall of the uncompacted material are checked with a camber board. Excess material should be spread over the embankment slope or transported by wheelbarrow to a convenient and safe dumping site. Material should not be deposited on the roadway or in the drain.</li> <li>▪ If the material is dry it should be sprinkled with water before compaction. The shoulder is then compacted with hand rammers or a hand roller. The compacted surface should butt smoothly onto the roadway.</li> <li>▪ Check the finished crossfall and repeat the reshaping if necessary.</li> <li>▪ Brush all loose material and debris from the roadway.</li> </ul>
<p><b>Shoulder rehabilitation mechanized method (19-02)</b></p>	<p>The procedure is as follows:</p> <ul style="list-style-type: none"> <li>▪ The existing surface of the shoulder is scarified with the tines of a motor or towed grader. This will loosen the raised areas and allow the loosened material to key into any existing low areas.</li> <li>▪ The shoulders are reshaped to slightly above the final level and the correct crossfall using a number of passes of the grader blade. Care must be taken not to damage the edge of the roadway with the blade.</li> <li>▪ Any low spots are topped up with fresh material of the same type as the existing shoulder. The cross fall of the uncompacted material is checked with a camber board. Excess material and vegetation should be graded to the embankment side slope. In cuttings, excess material and vegetation should be graded into a windrow for removal by wheelbarrow, tractor and trailer or truck. Material should not be deposited on the roadway or into the drainage ditch.</li> <li>▪ If the material is dry it should be sprinkled with water. The shoulder is then compacted using a self-propelled, towed or pedestrian roller. The compacted surface should butt smoothly onto the roadway.</li> <li>▪ Check the finished crossfall and repeat the reshaping if necessary.</li> <li>▪ Brush all loose material and debris from the roadway.</li> </ul>

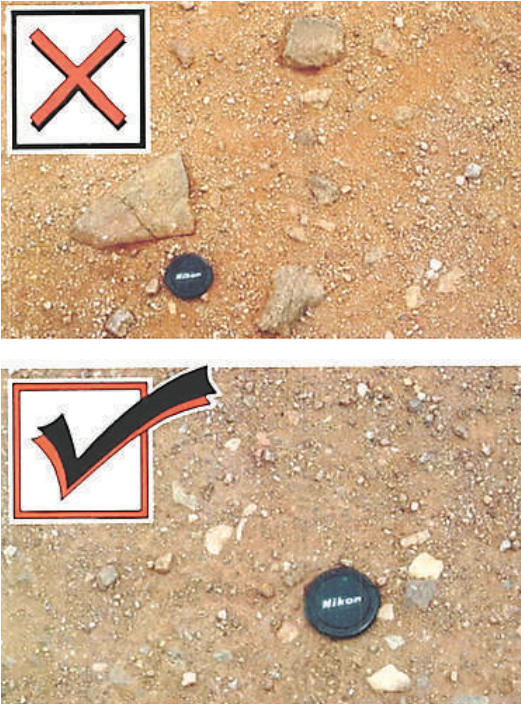

<p><b>Defect 20</b></p>	<p><b>Gravel layer too thin</b></p> 
<p><b>Development, if neglected</b></p>	<p>Road becomes very rough, slowing and damaging traffic. Water ponds on road surface. Vehicle wheels punch through the surface. Gravel surface loss increases and danger of total gravel layer loss and road becoming impassable.</p>
<p><b>Maintenance Activities</b></p>	<p><b>20-01 Regravelling</b></p>
<p>Gravel surfaces wear down due to the wasting effects of traffic and weather. Gravel loss rates can be up to 5cm or more of thickness each year even on a low traffic road. Re-gravelling is required when (or before) the residual thickness of gravel reduces to about 5 – 8 cm, otherwise there is a danger of vehicle wheels ‘punching’ through to the weaker material below. This would result in mixing of the materials and effectively the loss of the gravel layer.</p>	
<p>Gravel should be obtained from a recognized approved source and tested to meet materials specification requirements. The gravel can be either selected naturally occurring gravel material, or crushed stone aggregate. If crushed aggregate is used for regravelling works, it may lack plastic fines and therefore be prone to ravelling. It is preferable to use high quality natural gravel (where available) rather than crushed aggregate.</p> <p>Gravel should not contain any particles larger than about 4cm, as this will affect performance. ‘Oversize’ pieces should be hand- picked or ‘screened’ out.</p> <p>Due to the high cost of gravelling, technical advice should be obtained on sources and material suitability. If the material must be hauled a long distance (more than 5km) to the road, other types of road surface may be more economical. Whole life costing of all viable surface options should be carried out.</p>	 <p><b>Gravel materials (acceptable and not acceptable)</b></p>
<p><b>Diversion road</b></p>	<p>Before the re-gravelling work starts, a diversion may be opened up adjacent to the road. If traffic is diverted from the work site, it will enable the job to be carried out more efficiently and safely.</p>

<p><b>Quarry or borrow pit planning</b></p>	<p>Before the regravelling work starts, gravel should be stockpiled at the quarry or borrow pit.</p> <ul style="list-style-type: none"> <li>▪ Plan the quarry excavations and stockpiles so that:</li> <li>▪ The quarry can be fully exploited with economic removal of the maximum amount of gravel;</li> <li>▪ The overburden is stockpiled so that it will not hinder future extension, and that it can be used to reinstate the quarry;</li> <li>▪ The best material is taken, where gravel quality is variable within the quarry;</li> <li>▪ Material is stockpiled to minimise segregation; and</li> <li>▪ Environmental damage by poor drainage and erosion is minimised both during and after exploitation of the quarry.</li> </ul>
<p><b>Quarry or borrow pit layout</b></p>	<p>The layout of the quarry or borrow pit should:</p> <ul style="list-style-type: none"> <li>▪ Permit efficient excavation and stockpiling of gravel; and</li> <li>▪ Allow the trucks, tractor and trailers or other haulage vehicles to enter and leave without obstructions.</li> </ul> <div data-bbox="922 577 1445 891" data-label="Image"> </div> <p style="text-align: center;"><b>Quarry operations</b></p>
<p><b>Loading gravel</b></p>	<div data-bbox="528 958 1445 1552" data-label="Diagram"> </div> <p>At the quarry or borrow pit, the bulldozer or excavation laborers should have stockpiled sufficient gravel for the work. The excavating and stockpiling of gravel should create low, broad heaps to prevent segregation of the coarser material.</p>
<p><b>Site preparation</b></p>	<p>Traffic warning signs should be placed at either end of the re-gravelling site. The existing road surface must be graded-off or reshaped by hand to provide a firm regular surface on which to work. The graded/ reshaped surface should be watered and compacted. The camber should be checked with a camber board and the road level should fall 4 to 6 cm for each one metre width of road (4-6 %).</p>

**Drainage system**

The road drainage system should be checked and repaired if necessary (see Drainage defects and activities), otherwise the performance of the new gravel surface will be affected.

**Gravelling operations**

- When the initial grading/shaping of the road surface is complete, the loader or the quarry labor should start to load the tippers or trailers with gravel for transport to the re-gravelling site.
- The supervisor at the quarry should ensure that gravel is taken from the correct stockpiles and that the trucks/trailers are loaded correctly. Tippers or tractor trailers should always circulate continuously between the quarry and the site. Loading resources should be adjusted to keep the haulage equipment working continuously.
- Dumping should start at the far end of the site so that the heaps of gravel do not impede tippers or other haulage vehicles delivering later loads.
- On two lane roads, material should be dumped on one side of the road only;
- Loads should be placed at the correct spacing as instructed by the supervisor, necessary to give the required thickness of gravel over the complete road width after compaction;
- If the road is not closed, material should be dumped on the shoulder, or dumped and spread immediately by labor;
- The tankers or towed bowsers should have filled up with water using the pump and then have driven to the site;
- Initially the existing road surface is sprayed with water;
- Spreading of the gravel can start when there is a working length of about 200 metres of dumped material if using a motor or towed grader. If spreading is by labor, the gravel can be spread as soon as it is dumped, or unloaded by labor if non-tipping haulage equipment is used;

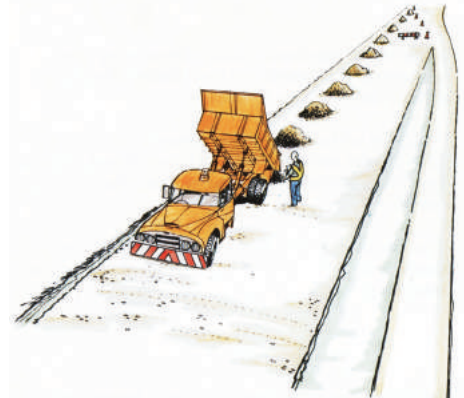

**Dumping gravel on the road**



**Extraction of water from a river**



**Off-loading and spreading gravel by labor-based methods**

- The material is alternately spread by the grader or labor and watered with the tanker/bowser until its moisture content is correct for compaction;
- The amount of water to be added must be determined by moisture content tests on site or by the supervisor;
- The tankers/bowsers circulate continuously between the site and the source of water;
- The new material is now graded or spread by labor to produce a camber of 4 to 6 cm for each one metre width of road (4 to 6 %); guide pegs and stringlines should be used with labor spreading;
- The camber should now be checked with the camber board at approximately 100 metre intervals along the road for machine spreading and every 10 metres if labor is used;
- To use the camber board, place it on its edge across the road with the shorter end pointing towards the center line and check the level bubble; if the bubble is central, the camber is correct;
- If the bubble is not central, the camber is either too steep or too flat and further grading/manual reshaping, and compaction are required;



- When the correct camber has been achieved, compaction can start using a self-propelled or towed roller, or a pedestrian vibrating roller for labor-based works;
- Water should not be added during rolling as the material may stick to the wheels or drums;
- Rolling should start at the edge of the road and work towards the middle. The roller should aim to progress from section to section at the same rate as the grader or labor operations;
- Typically, about eight passes of the roller will be needed to achieve full compaction;
- Gravel should not be compacted when it is dry as the subsequent gravel material loss from the surface will be high. Watering and good compaction help to preserve the investment in the gravel.

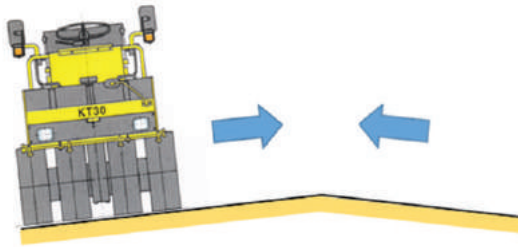

**Rolling sequence**



**Completed gravel road**

<p><b>Defect 21</b></p>	<p><b>Embrittlement of the bituminous surfacing due to hardening of the binder resulting in loss of aggregate, potholes and cracking.</b></p>	
<p><b>Development, if neglected</b></p>	<p>Water enters the road payment resulting in the pavement material becoming soft. Potholes, ruts and other pavement defects start to occur. Maintenance costs become very high and vehicle operating costs increase.</p>	
<p><b>Maintenance Activities</b></p>	<p><b>21-01 Resealing the road</b></p>	
<p>Sealing operations are covered in Part D on the Manual for Low Volume Roads. The key activities to be carried out are as follows:</p> <ul style="list-style-type: none"> <li>▪ Place warning signs and safety devices at either end of the work site;</li> <li>▪ Repair all potholes and other defects in the road surface;</li> <li>▪ Brush all loose material off the road;</li> <li>▪ Wash the road surface with water and stiff brooms;</li> <li>▪ Spray the approved binder on to the road surface at the specified application rate and in accordance with the manufacturer's guidelines using a hand lance or mechanical bitumen distributor;</li> <li>▪ Spread approved aggregate on the road surface at the specified application rate either by hand application or mechanical aggregate spreader;</li> <li>▪ Roll the surface with a pneumatic tired roller to bring the binder up through the aggregate and create a tight mosaic;</li> <li>▪ Carry out follow-up inspections of the sprayed surfacing work to correct any defects that may have occurred during the sealing operation; and</li> <li>▪ Tidy up the site and remove all traffic control signs and safety devices.</li> </ul> <p>Longitudinal joints in the seal should be minimised as these are a weak point in the surface. The width of the spray bar on the bitumen distributor should be adjusted so that the number of passes of the bitumen distributor is the same as the number of traffic lanes. The width of the spray bar should leave a 10 – 15 cm wide edge to the strip being surfaced with less binder, which is left uncovered by aggregate. This edge is then overlapped with the following pass of the bitumen distributor before covering with aggregate. Heavy rolling should be applied over the longitudinal joints to even out the joint and the built up ridge caused by bitumen over-spray.</p> <p>Transverse joints should be constructed using start and finishing sheets with the end of the previous section blinded off to make an accurate starting line for the new section. Transverse joints should never be placed on top of each other and they should be staggered by approximately 50 metres along the road.</p>		



<b>Defect 22</b>	<p><b>Road markings worn or covered due to resealing</b></p> 
<b>Development, if neglected</b>	Road users are unable to detect the edges of the carriageway, particularly at night and during the rains. This leads to unsafe driving conditions.
<b>Maintenance Activities</b>	<b>22-01 Repaint the lines on the road</b>
<p>Repainting of road lines must use an approved retro-reflective road-marking paint. The paint must be delivered to the site in sealed containers bearing the name of the manufacturer and the type of paint. The viscosity of the paint should be such that it can be applied without being thinned.</p> <p>Road markings should only be applied to bituminous surfaces after sufficient time has elapsed to ensure that damage will not be caused to the painted surface by volatiles evaporating from the binder in the surfacing.</p> <p>The procedure for repainting lines on the road surface is as follows.</p> <ul style="list-style-type: none"> <li>▪ Place warning signs and safety devices to protect the workers from vehicles;</li> <li>▪ Clean the surface of the road with water and a stiff brush for this it is completely free from any soil, grease, oil, acid or any other material which will be detrimental to the bond between the paint and the surface;</li> <li>▪ Allow the surface of the road to dry;</li> <li>▪ Premark the lines using paint spots of the same colour as that of the final lines, with the paint spots not more than 1.5 m apart;</li> <li>▪ After spotting, the positions of the road markings must be approved by the Engineer prior to commencing the painting operations;</li> <li>▪ Stir the paint in accordance with the manufacturer's instructions and apply it without the addition of thinners;</li> <li>▪ After painting, tidy up the site and remove all traffic control signs and safety devices.</li> </ul> <p>Where the paint is applied by machine, it should be applied in one layer. The satisfactory operation of the painting machine should be demonstrated on a suitable site away from the permanent works prior to starting the painting operations.</p> <p>Where the painting is done by hand, the paint should be applied in two layers, with the second layer applied after the first layer has dried. As most road-marking paint reacts with the bitumen in the surface of the road, the paint should be applied with one stroke only of the brush or roller.</p>	



## 3. MAINTENANCE MANAGEMENT CYCLE

### 3.1 Introduction

All maintenance operations require careful planning, supervision and monitoring. The maintenance management cycle in Figure E.3.1 shows the required activity phases.

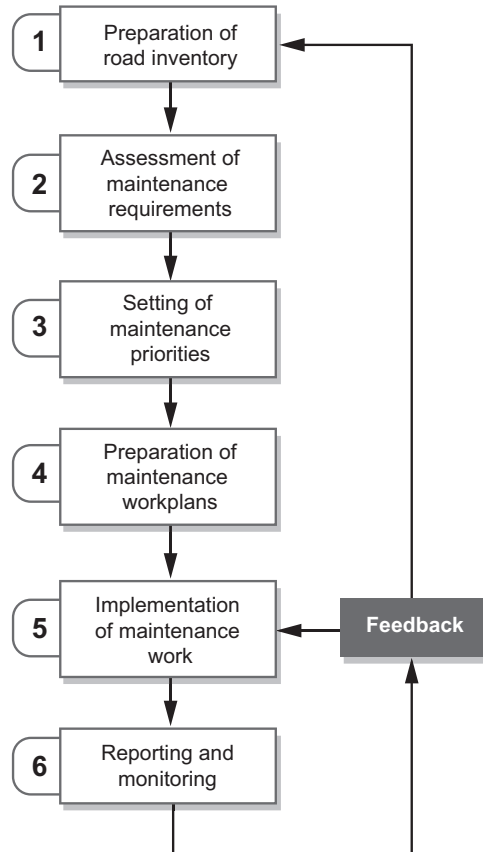

The maintenance management cycle begins with the road inventory and an assessment of the maintenance requirements of the network. Since the maintenance needs normally exceed the available budget there is the need to prioritise the maintenance activities. After the prioritisation, the work plans are prepared, and the maintenance work is implemented. The cycle ends with reporting, evaluation and monitoring. The results from the monitoring is fed back into the management cycle to improve the process in the next round of maintenance.

**Figure E.3.1: The Road Maintenance Management Cycle**

(Source: MPW Maintenance Management Manual, 2009)

### 3.2 Road Inventory

The inventory is a set of information about the basic characteristics of the road network. For purposes of the road inventory the network is divided into links of equal length, normally 5 km. The inventory includes the key features of each link on the network. This includes the road and link identification codes, surface type (paved or unpaved) and road width. A standard form for collecting the road inventory data is included in Appendix E.3.

The collection of the road inventory data does not need to be repeated every year. However, it may be necessary to update the inventory periodically if upgrading works are carried out on parts of the network or new roads are built.

### 3.3 Drainage Structure Inventory

Separate inventories are prepared for drainage structures including culverts and bridges. The inventory should include the road identification code, road location, location of the structure, structure type, size, length, etc. Standard forms for collecting culvert and bridge inventory data are included in Appendix E.4 and E.5.

### 3.4 Prioritisation of Maintenance Works

#### 3.4.1 Principles of Prioritisation

Maintenance is most effective when applied to 'maintainable' routes, that is roads that serve the needs of the road users and have only minor defects that can be rectified using routine maintenance. This

is preferable to trying to maintain roads that do not serve the needs of the road users as a result of major defects which require rehabilitation, for example un-drained tracks and sunken road sections. Maintenance of roads in very poor condition may consume a lot of resources with limited impact.

Maintenance should always take importance over any route upgrading or improvement works. A roads agency should protect what it has before extending its assets and liabilities.

The first questions to ask in the prioritisation process are:

- Which routes can be maintained with the annual budget? and
- Which maintenance activities should be undertaken?

### 3.4.2

#### Prioritisation Process

The routes with the highest maintenance priorities should be determined by the road agency in consultation with community representatives. The information on road priorities should be displayed at prominent community locations.

For simplicity and clarity, it is best to divide the roads into 2 or 3 priority groups based on the following criteria:

- Is the road a strategic inter-community or main road link;
- Is the traffic high (e.g. more than 50 motor vehicles/day) or low?
- What is the population served by the road?
- What value of crops is extracted each year from the area served by the road?
- Does the road serve markets, educational or health facilities? and
- Is the road maintainable - that is, does it already have camber and working drainage system and is it passable all year round?

The above factors can be combined using a Multi Criteria Analysis (MCA) with values and weightings given to each factor in order to establish the highest priority routes for maintenance. An example of an MCA for route selection is given in Part A Chapter 3. The MCA should be repeated annually, though most of the data will not change significantly from one year to the next.

An example of a simplified road prioritisation is given in Table E.3.1.

**Table E.3.1: Example of simplified road prioritisation**

Route	Length (km)	Daily traffic in motor vehicles	Days impassable last year	Reasons for priority
<b>Priority A</b>				
Main road to Town A	6.0 km gravel	65	0	Main access road serving high population
Town A to Village B	3.5 km gravel	50	0	Access for school and timber exports
<b>Priority B</b>				
Town A to Village C	4.5 km gravel	20	0	Horticultural area
Village B to Village C	5.0 km earth	15	5	School access
Village C to Village D	7.0 km earth	<10	15	Access to brick factory, sunken sections

Road maintenance can also be prioritised using a proprietary Asset Management System, several of which are available on the market. The system should be adaptable to national maintenance policies and regulations and used to standardize maintenance practice countrywide. The available packages typically include capability for budgeting, planning and management of emergency, routine and periodic maintenance. Data can be exported to HDM 4 for economic appraisals. The system

requires a detailed inventory of the road network and accurate road condition data, which must be updated annually.

### 3.5 Assessing Maintenance Needs

#### 3.5.1 Annual Condition Survey

An annual visual road condition survey is carried out by the road agency of all links on the network. This is a key requirement for the road network asset management system. The annual visual condition survey assesses common defects on the road in terms of their degree and extent using a standard form (see Appendix E.6).

From the annual condition survey, the road inventory prioritisation, and the available budget, the road agency decides which road links should receive periodic maintenance, routine maintenance, spot improvements, or no maintenance during the following year.

The annual road condition survey also enables the road agency to determine key asset management performance indicators. These include the Network Condition Index (NCI), the Network Pavement Condition Index (NPCI), the Network Functionality Index (NFI), and the road network Current Asset Value (CAV)<sup>1</sup>. These indicators are used by the road agency to monitor its performance on an annual basis and compare its performance with other road agencies in the country.

#### 3.5.2 Monthly Condition Survey

The information gathered from the annual visual condition survey is not sufficient to prepare detailed plans for routine maintenance. Monthly maintenance needs surveys are therefore carried out on the prioritised road links. Maintenance requirements are recorded on a standard form (see Appendix E.7).

Where it is possible to arrange routine maintenance at different times of the year, the following seasonal priorities should be made:

During rains: Remove blockages to drainage system, emergency repairs.

End of rains: Reshape surface on unpaved road sections.

Dry season: Road surface repairs on paved sections, roadside activities, drainage system & periodic maintenance.

In this way the vital road drainage system is prepared for the rainy periods and is kept functioning through the rains. The earth and gravel surfaces are most effectively maintained immediately after the rains when there is moisture in the materials to help consolidate them after reshaping. Paved roads may have minor defects (e.g. small potholes or cracks) which may propagate very fast and become severe during the rains. These defects should be repaired before the rains.

### 3.6 Preparation of Maintenance Work Plans

The data from the monthly maintenance needs survey is transferred to a computer spreadsheet which enables the total expected cost of the maintenance work to be estimated. Quantities of works can then be adjusted to reach a total value within the available budget. Instructions are then given to the maintenance contractors or in-house works units for the maintenance works to be carried out during the following month. The monthly scheduling should, as far as possible, aim to meet the targets of the annual schedule for each road link.

### 3.7 Supervision and Reporting

Supervision of the maintenance works is carried out by road agency staff and the contractor. If the works are being carried out by force account, more supervision is required from the road agency staff. If the works are being carried out through a contracting arrangement the contractor takes responsibility for day-to-day supervision of the workforce, but the road agency representative should visit the site at least once a week.

- The purpose of supervision is to:
- ensure that the work is carried out in accordance with the contract specifications and standards;
- monitor and control the productivity on site;
- correct and instruct when and where necessary;
- arrange any additional operational inputs;

1. These indicators are defined in the Glossary of Technical Terms.



- control costs;
- Agree on quantities of work done for payment purposes; and
- receive feedback to prepare for future contracts.

Gang leaders are appointed for each group of laborers. The gang leaders are provided with instructions for the work to be carried out on a weekly basis. Their responsibility is to organize the workforce with daily work targets, ensure the quality of the work, and prepare daily production reports. The daily reports are collected by the supervisor who prepares consolidated weekly and monthly reports for the road agency. If the works are being implemented through a contract, the daily work sheets must be signed by the road agency representative as they form the basis for the monthly payment certificate.

At the end of each month the road agency maintenance engineer prepares a report of all maintenance works carried out during the month compared with the targets set in the monthly maintenance work plan. At the end of the year the engineer prepares a report on the works carried out during the year compared with the annual plan. The annual report should include an analysis of constraints faced during the year which may have resulted in failure to meet the maintenance targets, as well as recommendations for avoiding similar difficulties in the following year.

The recommended reporting structure for the maintenance system is summarised in Table E.3.2.

**Table E.3.2: Reporting structure**

General planning and reporting systems	Report required
Daily	Daily site diary Daily site record of works
Weekly	Records of site instructions Weekly works measurements (planned versus actual) Inspection reports
Monthly	From site to District Engineer <ul style="list-style-type: none"> <li>▪ Progress (planned versus actual)</li> <li>▪ Statistics (labor and equipment employed if force account operation)</li> <li>▪ Financial obligations (interim payment certificate if contracted work)</li> <li>▪ Problems encountered</li> <li>▪ Planned works for the following month</li> </ul> Summary to SLRA Head Office
Quarterly and yearly	From District Engineer to SLRA Head Office <ul style="list-style-type: none"> <li>▪ Summary progress report (planned versus actual)</li> <li>▪ Financial report</li> <li>▪ Summary of achievements and review of constraints and how they were overcome.</li> </ul>

### 3.8 Road Improvement and Emergencies

Each year an assessment should be made of any spot improvements or upgrading of the roads that should be made with the available resources. This may include improved road surfacing on vulnerable sections or raising the road level to prevent seasonal flooding of the road. Spot improvements may be carried out on minor roads and tracks to ensure basic access for the local community.

Emergency repairs may be required if the road is damaged to an extent that the safety of traffic or the road structure is endangered, for example a route becomes impassable during the rains due to a wash-out of a culvert or subgrade failure. The reasons for the damage should be investigated and a long-term solution developed. The repair work should be implemented as soon as possible. Assistance or advice may be required from the Ministry of Public Works.

Road improvement and emergency works normally involve preparing a separate contract for the work or may involve separate works units under a force account arrangement. Spot improvements may be included in routine maintenance contracts if the works are to be carried out on the same road.

## 4. WORK OPTIONS

### 4.1 Summary of Options

There are a number of ways that maintenance work can be organised depending on the financial and human resources available, and technical capacity of the road agency.

In practical terms, the maintenance of Low Volume Roads (LVR) is normally carried out by labor methods with occasional support of intermediate or heavy equipment. The use of heavy equipment is often too expensive to mobilise and inefficient for remote, small scale, rural road maintenance.

The main work organization options are:

- Option 1- Small Contractor (Private);
- Option 2- Large Contractor Based System.
- Option 3 - Force Account;
- Option 4 - Hire-in equipment (in combination with other options);
- Option 5 - Community or Religious Group;
- Option 6 - Length Person or Family Contract;
- Option 7 - Compulsory/Voluntary Labor;

### 4.2 Option 1- Small Contractor (Private)

The small enterprises will normally be based in the county. They may be general or building contractors with established contracting experience in earthworks, masonry and concrete skills. They would be expected to make use of local labor and may have access to light equipment such as a concrete mixer, tractor or roller. This implementation option is suitable for all maintenance activities.

#### Advantages:

- Overheads lower than big contractor;
- Low mobilization and demobilization costs;
- The contractor is likely to obtain the required range of building and maintenance skills from the community;
- Good prospects for local employment and money being injected into the community; and
- Local enterprises are normally committed to the community and may be under some pressure to perform well.

#### Disadvantages:

- The time, resources and costs involved with managing the contract may be high;
- If the market for maintenance works is not developed the prices may be unreasonably high (guideline unit costs should be made available by the Ministry of Public Works);
- Small contractor may not own or be able to hire the required equipment;
- The contractor may initially require some training or a higher level of supervision than large contractors; and
- The contractor may have difficulty in obtaining credit for purchases, or financing cash flow and must therefore be paid promptly at the end of each month.

### 4.3 Option 2 – Large Contractor Based System

Large equipment-based contractors are usually based in the capital city or regional centers. The contractor may be engaged to construct a road as well as to maintain the road for some years after the initial construction phase. To reduce costs the contract may include a cluster of roads in the area.

#### Advantages:

- Large contractors normally own equipment or are able to hire it;
- Large contractors can normally obtain credit for purchases, or financing cash flow; and
- The contractor may require less direct supervision than a small contractor.

- **Disadvantages:**
- Overall costs may be higher than small contractors due to higher overheads, mobilization and demobilization costs and profit components;
- The contractor is likely to bring skilled and semi-skilled workers from outside the local community; and
- Less employment is provided in the local community and less money injected into the local economy.

#### 4.4 Option 3 – Force Account

This option makes use of a permanently employed and equipped workforce to carry out the maintenance work such as county road management units. This implementation option is suitable for all maintenance activities.

##### **Advantages:**

- Direct response to all maintenance needs;
- Rapid mobilization when funds are available;
- Retain skills and experience within organization, familiarity with the network, standards, work methods;
- Minimum of works documentation requirements; and
- Dealings/ disputes with outside parties minimized.

##### **Disadvantages:**

- A predictable annual budget is necessary to support this option as monthly salaries must be paid;
- Inefficiency in equipment procurement and the lowest initial purchase cost policy can hinder standardization and efficiency;
- Poor mobility of the workforce around the network unless transport is provided;
- Paid labor and equipment may be standing if no funds are available for fuel and materials;
- Poor management may result in inefficient use of available resources and poor cost-awareness;
- Little pressure to try new solutions and technologies; and
- High mobilization and demobilization costs if the maintenance units are based at the central level.

#### 4.5 Option 4 – Hire-in equipment

This option may be used to supplement options, particularly force account, to provide equipment for specific operations such as towed grading or materials haulage. The funding could be provided by the Ministry of Public Works, the County Council, an NGO, or a benevolent trader, farmer or other well-wisher.

##### **Advantages:**

- This option includes most of the advantages of force account, with the additional advantages that:
- The equipment is under the direct control of the road agency;
- Equipment is hired only when funds are available;
- Rapid mobilization is possible if hiring facilities exist in the county; and
- The roads agency is not required to make a large capital outlay to purchase equipment.

##### **Disadvantages:**

- In many rural areas of Liberia there are no local hiring facilities for equipment;
- High mobilization and demobilization costs if the equipment hiring company is far from the site; and
- The hiring company might be slow to attend to breakdowns of the equipment on site.

## 4.6

**Option 5 – Community Based Organisation (CBO)**

This consists of the use of a group of persons based within the community and organized specifically to carry out the routine maintenance works under an agreement or contract with the road agency. This can be for a single route, or a number of routes serving the community. This approach differs from the length person or family contract approach only in that the number of persons expected to be involved would be greater, and that consequently work may be concentrated at a particular time or times of the year. This option can be particularly suitable for the Routine Maintenance activities

**Advantages:**

- Low cost compared to most other forms of contract (due to low overheads, low mobilization and demobilization costs, absence of profit component, and local participation);
- Can be cash or in-kind payment according to community circumstances;
- Simple contract/agreement required;
- Direct response to Routine Maintenance needs – rapid mobilization, or planned seasonal inputs;
- Retain skills and experience within the community, familiarity with the network and any problem sections;
- Close control of the works personnel;
- Anticipated good production due to pride of ‘ownership’ for the network, and appreciation of importance of the asset to the community;
- No dealings/disputes with parties outside of the community;
- Employment and money/resources recycled within the community; and
- Employment can be targeted at poor or disadvantaged persons in the community.

**Disadvantages:**

- Community groups can only carry out routine maintenance activities;
- Possible difficulties in controlling output and quality;
- Not suitable in areas of dispersed or low population density;
- No capability to organize equipment;
- May not have access to construction quality hand tools so that the road agency may have to purchase these in advance;
- Community groups may not have members who are professionals or semi-professionals in the road industry; this may result unprofessional work and failure;
- Workers may initially require some training; and
- Community groups are usually supported by government for the sake of a job creation initiative and may not comply with all legal procedures; this may lead to problems in the implementation stages.

## 4.7

**Option 6 – Length Person or Family Contract**

A contract or agreement is drawn up with an individual or family to carry out specified routine maintenance activities on a road at certain times of the year for a payment in cash or in-kind. The works may be on a full-time or part-time basis.

Usually a laborer is appointed for a distinct section of road close to his/her home, typically 1.0 to 1.5 km in length. He or she is provided with all the necessary (construction quality) hand tools to carry out all the routine maintenance activities as instructed by a supervisor from the Ministry of Public Works or the County Council.

**Advantages:**

- Many of the advantages are the same as for the CBO and include:
- A single person can be made fully responsible for a section of road;
- Low cost compared to most other forms of contract due to low overheads, low mobilization and demobilization costs, absence of profit component, and local participation;
- Can be cash or in-kind payment according to community circumstances;
- Simple contract/agreement required;

- Flexible approach to seasonal needs - rapid mobilization;
- Pride of 'ownership' for the network;
- No dealings/disputes with parties outside of the community;
- Employment and money/resources recycled within the community;
- Employment can be targeted at poor or disadvantaged persons in the community;
- Assured of continuous maintenance all year round; and
- Contract can be for several years renewable annually based on performance.

**Disadvantages:**

- A high level of supervision is required to control output and quality – the system will degenerate if the supervisor is not continuously mobile and effective in the management;
- Not suitable in areas of dispersed or low population density;
- No capability to organize equipment;
- May not have access to construction quality hand tools so that the road agency may need to purchase these;
- Workers may initially require some training; and
- There is no guarantee of continuity of the agreement if the person is displaced or moves to another area.

## 4.8 Option 7 – Voluntary Labor

The use of local (community) labor to carry out maintenance works on the roads on a 'no-fee' basis is one of the options for maintaining community roads, especially roads which do not receive annual road agency funding. The approach can be suitable for simple Routine Maintenance activities such as grass cutting and clearing of drains. It has been used successfully on LVR and routes without government responsibility. If the whole community can be persuaded to attend a 'maintenance day' once or twice a year with their hand tools, there may be sufficient labor resources to carry out the necessary maintenance work under the guidance of a trained supervisor. This is the cheapest way to maintain an LVR and involves no taxation, cost or levy to the community. Everybody contributes and benefits equally. Wealthier inhabitants, traders or other well-wishers can contribute hand tools, equipment rental or food to create a community occasion.

**Advantages:**

- No financing or cash accounting required;
- In richer communities, individuals can elect to pay cash instead - this can provide funding for materials, handtools and equipment hire, or even paid labor;
- Minimum of works documentation requirements;
- Direct response to all maintenance needs;
- Rapid mobilization;
- Retain skills & experience within the community;
- Direct supervision of works;
- Pride of 'ownership' for the network; and
- No dealings/disputes with outside parties.

**Disadvantages**

- Can be a severe burden on the community's poorest persons;
- May be difficulty in motivating and organising inputs;
- Difficulties in controlling output and work quality;
- Not suitable for work during the agricultural 'high' season;
- Not suitable in areas of dispersed or low population density;
- Few prospects for PAID community employment or money being injected into the community;
- No capability to organize equipment;
- May not have access to construction quality hand tools; and
- May initially require some supervisor and 'gang leader' training.



## 4.9 Forms of Contract

There are several forms of contract that can be used for the contracting of road maintenance to private sector contractors. The two most common forms of contract are summarised below.

### Remeasured contract

The traditional form of contract uses bills of quantities or schedule of rates, with unit rates for each maintenance activity. The rates are either provided by the contractor in a tender or determined by the client. The contractor is paid according to the quantity of work done. Each bill item is linked to a specification which describes what the contractor is required to do in order to receive payment. This form of contract is the basis for the maintenance specifications provided in Annex E.1.

The remeasured form of contract requires a high level of supervision by the client. The contractor must be given instructions for the work required to be carried out. The client supervisor must then agree the measurement of work completed by the contractor at the end of the month in order to prepare the payment certificate.

The advantage of the remeasured form of contract is that the client only pays for work actually done on the road. It is suitable for maintenance contracts with small emergent contractors as they are not required to carry any risk for unforeseen road deterioration.

### Performance-based contract

Performance-based contracts require the contractor to accept the greater part of the risk for predicting road deterioration. The contractor must plan and specify the long-term maintenance needs for each road to satisfy an outcome-based performance specification adopted by the client. The specification requires the contractor to maintain the road in a certain minimum condition. This may be described, for example, by a maximum roughness level or minimum average speed of travel. There may be a requirement in the specification to maintain the grass growing at the side of the road below a certain height. The contract is usually lump sum, with monthly instalments. If the performance standards are not achieved, appropriate deductions are made from the monthly instalment. The formula for assessing the deductions must be specified in the contract.

When bidding for a performance-based contract, the contractor must predict the rate of deterioration of the road and therefore the maintenance requirements. This form of contract is therefore most suited to large experienced contractors. Small emergent contractors are not able to take on the risk of unforeseen deterioration, particularly of unpaved roads. The contractor requires substantial in-house planning and management capability. Less supervision is required by the client, but the client must have a regular presence on site to verify that the minimum performance levels are being achieved. For low volume rural roads, it is normally sufficient for the client supervisor to visit the road once a month.

Performance-based specifications are often used for the maintenance of a road following construction, with the works contractor given responsibility for the maintenance over an extended period (up to ten years in some cases). Under this type of contract, it is important that the standard of the road at the end of the contract period is clearly defined.

Performance-based maintenance contracts tend to be expensive as the contractor is required to carry a high level of risk. They are more suited to paved roads carrying higher levels of traffic than low traffic unpaved roads. On unpaved roads the deterioration is normally due more to environmental factors than the traffic. This form of contract can be unpopular with local communities, if the community does not understand the mechanism of the contract. For example, when the road is new the community might not understand why the contractor is receiving payment without doing any work on the road.

## 4.10 Area-based road maintenance

Under area-based road maintenance the contractor is based in a camp, normally close to a district centre. The contractor is responsible for the maintenance of a network of roads in the vicinity of the camp. The maintenance works can be specified using a re-measured form of contract or a performance-based specification.

The camp is equipped with basic tools and equipment for maintenance activities. For the maintenance of unpaved roads, the camp is typically equipped with a tractor, towed grader and tire drag, though this may depend on the soils in the area and the material used for gravel wearing course. Full-time

staff employed by the contractor at the camp typically includes a supervisor, mechanic and clerk. When labor is required for maintenance tasks, people are recruited from the local community.

The area based system lends itself to multi-year contracts, with the team based at the camp becoming familiar with the maintenance needs of the network over the extended period of time. Under a performance-based specification this may assist the contractor to optimize the maintenance inputs and thereby maximise profit.

The area based maintenance system is easily adapted to force account operations. The maintenance unit is based permanently at the camp and is provided with fuel, spares, construction materials etc. by a centralised organisation. The unit carries out prescribed maintenance activities which vary depending on the time of year. This system has been successfully implemented in Zimbabwe by the District Development Fund since the 1980s on a network of 25,000 km of unpaved roads (Gongera, et al, 2003).



**Figure E.4.1: Maintenance base camp in Zimbabwe**

## 5. WORK PLANNING AND PRODUCTIVITY

### 5.1 Outline Planning Guide

It is important to plan the maintenance works according to the defect repair needs, the priorities and the resources available to carry out the works.

The following labor resource requirements can be used as an outline planning guide (Table E.5.1).

**Table E.5.1: Outline routine maintenance planning for LVRs**

Number of Person-days of work expected/km/year				
Number of "wet" months	Gravel	Gravel	Earth	Earth
	< 50vpd	> 50vpd	< 50vpd	> 50vpd
4	40	45	45	52
8	68	75	79	88
12	100	107	115	125

#### Notes:

- i. Number of "wet" months per year are with rainfall >125mm.
- ii. Estimates assume 'maintainable' road with proper camber and drainage system. Not applicable for problem soils such as 'black cotton' and unpaved roads in steep terrain.
- iii. Does not include periodic works such as re-gravelling.

With good record keeping the data in Table E.5.1 can be refined by the road agency or contractor and used to estimate the total labor resources required for the maintenance program and estimate the total labor cost. The cost of equipment inputs must also be included. Earth and gravel roads typically require light reshaping by grading between 1 and 4 times per year.

### 5.2 Productivity Targets

To plan and manage maintenance works it is useful to have productivity standards, norms or targets. These need to be flexible considering the variable nature of LVR maintenance works, the location of the works, and the experience of the supervisor and workforce. The development of local productivity norms or targets can take considerable time to achieve. The productivity targets included in Table E.5.2 were developed in East Africa but provide a guide to planning maintenance works in Liberia. Some modifications have been made to the East Africa values based in experience on the Liberia-Swedish Feeder Road Project.

The targets represent the expected productivities that can be achieved with a well organised and managed workforce. They should therefore be used as targets to be worked towards. It is expected that under normal conditions, 60% to 80% of the productivity standards should be achieved. Good record keeping will allow local productivity standards to be developed over time.

Table E.5.2: Productivity targets per person-day

Code	Maintenance Activity	Unit	Task Difficulty				Notes
			1	2	3	4	
2-01	Cut grass	m <sup>2</sup> /day	400	300	200	-	Difficulty = Density of grass cutting 1) Light 2) Medium 2) Dense
2-02	Bush clearing - light	m <sup>2</sup> /day	425	350	275	-	Difficulty = Density of bushes 1) Light 2) Medium 2) Dense
3-01	Plant grass and water	m <sup>2</sup> /day	100	-	-	-	Difficulty 1) Normal conditions
4-01	Culvert Cleaning	No. per day (60cm diam, 7m long)	4	3	2	1	Difficulty = Silt depth 1) up to 1/4 2) 1/4 to 1/2 3) 1/2 to 3/4 4) over 3/4
5-01	Drain Clearing - Manual (Culvert outfall)	m/day	55	40	25	-	Difficulty = Silt Depth 1) Up to 10cm 2) 10 to 20cm 3) Over 20cm
5-01	Drain Clearing - Manual (Turnout drains)	m/day	60	45	30	-	Difficulty = Silt depth 1) Up to 10cm 2) 10 to 15m 3) Over 15m
5-01	Drain Clearing - Manual Wet areas Dry soft soil Dry hard soil	m/day	65 55 30	45 40 23	30 30 18	-	Difficulty = Silt depth 1) Up to 10cm 2) 10 to 15cm 3) Over 15m
6-01	Construct or replace scour check	No/day	5	7	-	-	Difficulty = Type of scour check 1) wood 2) stone
9-01	Mortared Masonry Repair	Square metre of wall per day	14	8	-	-	Difficulty = Depth of damage 1) Up to 15cm 2) 15 to 30cm
10-01	Dry Masonry Repair	Square metre of wall per day	14	8	-	-	Difficulty = Depth of damage 1) Up to 15cm 2) 15 to 30cm
12-01	Reshape & Compact Earth Road Camber (labor-based)	m/day	70	50	-	-	Difficulty = Type of reshaping over road width 1) (Light) up to 75mm cut 2) (Heavy) over 75mm cut

Code	Maintenance Activity	Unit	Task Difficulty				Notes
			1	2	3	4	
13-01	Spot Repair - Selected Material	Wheel barrows/day	25	18	13	8	Difficulty = Hauling distance from stockpile 1) up to 100m 2) 100 to 200m 3) Over 200m
14-01	Grade Gravel Road (light)	km/day	10	-	-	-	Difficulty = 4 passes more than 3cm of cut. Excludes mobilisation & demobilization
15-01	Grade Gravel Road (heavy)	km/day	4.2	-	-	-	Difficulty = 8 passes more than 3cm of cut. Excludes mobilisation & demobilization



## 6. SAFETY DURING MAINTENANCE OPERATIONS

Whenever maintenance works are carried out the following safety measures should be observed:

- Ensure that safety gear have been issued to all personnel on site and they have had safety training;
- Provide temporary traffic signs and barriers correctly located on site at both ends of the works site and a sufficient distance away to warn road users of works underway ahead (see Figure E.6.1 and Figure E.6.2);
- Assign flaggers at both ends of the works site to control traffic flow during the maintenance operations (see Figure E.6.2);
- Ensure that traffic-control operations are properly carried-out for the safety of workers and road users and that road users are not unnecessarily delayed;
- Ensure that all equipment and vehicles are parked off the carriageway or behind protective barriers and signs, when not in use;
- Ensure that no materials are left in a location where they may interfere with the flow of traffic and that the road adjacent to the worksite is kept clean, swept of any debris arising from the work;
- Ensure that all excavations are clearly marked and protected for the benefit of all road users, equipment and workers;
- Ensure that all operators are trained in operating their equipment;
- Inform operators and labor of the potential risks and procedures for working with or close to machinery;
- Ensure that where work on the carriageway or shoulder remains unfinished overnight, proper warning lights and/or barriers are provided; and
- Ensure that all sites are left tidy and cleared of debris when the work is completed.

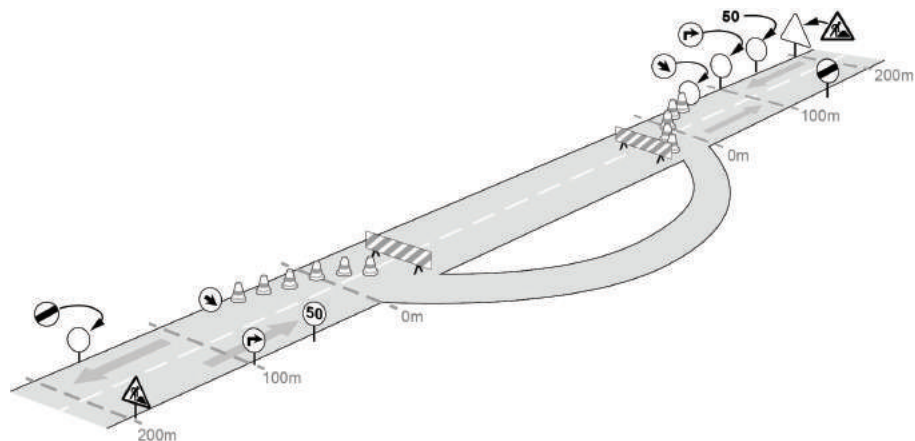

**Figure E.6.1: Sign posting for diversion of traffic off the road**

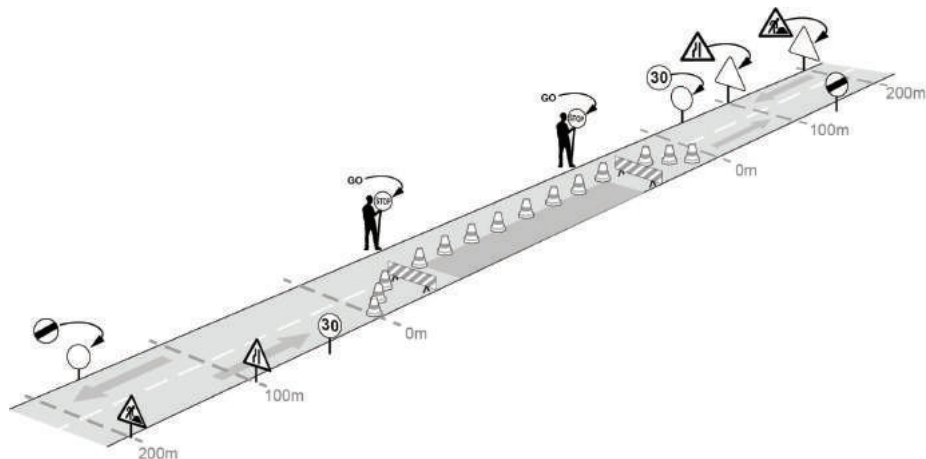

**Figure E.6.2: Sign posting for diversion of traffic to one side of the road**

## 7. MAINTENANCE OF BRIDGES & STRUCTURES

### 7.1 General Requirements

Cross drainage structures may account for a high proportion of the total investment cost of a road. They are the potential weak points in a rural road network due to the possible damaging effects of floods and high water flows being concentrated at the points where the water crosses the road. The failure of these structures results in high replacement costs and disruption in the free flow of traffic on the road. It is therefore particularly important that full attention is given to maintenance of structures to ensure that they are always in good condition. If the maintenance is not carried out, there may be serious consequences for road users. It can result in increased safety hazards, reduced quality of service or even loss of the structure and severing of the transport link.

A culvert, bridge or other structure is an integral part of the road. Its condition affects the level of service that the road provides. A structure should be designed so that no major repair works are required during its 'design life' (e.g. replacement of abutments, piers or deck structural members). Eventually major works may be required such as a new timber bridge deck or safety barrier replacement.

It is usually not possible to devise a 'maintenance-free structure' for a watercourse crossing at affordable cost. However, application of the design and construction guidelines contained in this LVR Manual series should reduce maintenance requirements to an acceptable and manageable level. Conversely, poor design or construction will result in an abnormally high requirement for maintenance, or even eventual loss of the structure.

There are a number of aspects which should be appreciated in devising appropriate management and maintenance arrangements for structures. This applies to individual structures, or a large number of structures at various locations on a road network.

Structures will often need no maintenance for periods of many months or sometimes even years. Deterioration or damage to a structure can progress slowly (e.g. corrosion, attack by insects), or suddenly (e.g. in a flood or vehicle accident). The need for repairs may not be obvious to road users or through casual observation from the road. However, the deterioration can progress, if not checked, to result in the need for major works at great cost and requiring substantial unplanned resource mobilisation.

The resources for maintenance and repair of a typical structure are required intermittently, not continuously. It is usually most efficient to provide maintenance resources only when the structure requires maintenance or repair works.

### 7.2 Managing Structures

The maintenance works required to be carried out on a structure will range from basic seasonal clearing of silt and debris through to replacement of components of the structure when they are worn out or damaged.

It is necessary to set up a structures management system to ensure that each structure on the road network stays in a condition that it is able to carry out its function in a safe manner. This 'system' should identify when work needs to be carried out on each structure and prioritise the work in accordance with the budget. Regular inspections are required to identify any damage or deterioration of the structure, or problems adjacent to the structure which may threaten its stability.

The key components of a structures management system are:

- An inventory of all structures (i.e. What is the asset? What are its key features? These are management records which generally do not change with time, except for new structures or after major structural changes to an existing one);
- An inspection system (to determine the condition and repair needs);
- Arrangements for specifying, arranging, supervising, recording/reporting and paying for the works. Arrangements should also be in place for checking the 'value for money' of maintenance operations and expenditures.

Overseas Road Note 7 provides comprehensive guidelines on the inspection and documentation of inventory and condition information on structures. A paper based system is adequate. Computer

systems can help if the number of structures being managed is substantial and the operating environment can support the maintenance of the computer system. In a limited resource environment, it can be difficult to justify and secure the recurring costs of administration, computer support personnel and inevitable software and hardware upgrades required for a computer system, i.e. there can be an undue and unnecessary dependence on external resources.

Certain maintenance activities such as de-silting and removal of debris should be carried out under a regular programme of works in conjunction with the road maintenance. For example, before the rainy season all silt should be removed from culverts, their inlets and outlet channels. After the rains, and particularly after individual floods, silt and debris should be cleared from structures to avoid later damage due to blockages or diversion/concentration of water.

These regular clearing operations are an ideal opportunity to carry out an inspection of a structure. With the scarcity and expense of engineering personnel, it is possible to train persons with limited education (e.g. the gang leader) to carry out inspections and to alert engineering staff to situations that require action.

Inspections of all structures should be carried out after a flood situation as this is the most likely time for damage to have occurred. Particular attention should be paid to identifying any movement, especially at joints, cracking/spalling and assessing whether erosion has occurred around abutments and piers, or at the ends of aprons. Where water is permanently standing against the structure, probing with ranging rods, poles or plumb lines should be carried out to identify unseen scouring. A boat or raft may be required for this inspection.

All structures, from culverts to bridges, should receive a documented routine inspection at least once each year. Inspection records should be carefully filed for future reference. Even a report of 'no defects' is important management information.

The management of a structure costs money. Before a structure is built, the ongoing provision of the funds and resources for the management (including inspections) as well as the maintenance of the structure should be assured.

### 7.3 Maintenance Activities

Structure maintenance activities can be grouped into regular or routine maintenance (Table E.7.1), and periodic major operations (Table E.7.2).

Maintenance records should be kept for each structure, which include:

- Estimates of work proposed;
- Details of work carried out;
- Date of completion of the repair;
- Supervisor's quality control reports;
- Actual costs of repair.

Storage of information should be on a structure by structure basis so that the complete history can be easily viewed.

Major repairs to structures require technical expertise for the design and supervision of remedial work.

**Table E.7.1: Structure maintenance activities (routine)**

Cleaning/clearing
Sweeping
De-silting
Unblocking
Removal of vegetation and flood/wind borne debris (This includes inlets and outlet channels as well as culvert barrels)
Repair of loose/missing connectors and fixings
Replacement of damaged/missing planks or kerbs

**Table E.7.2: Structure maintenance activities (periodic)**

Random stone filling
Retaining wall repairs, pointing/repair of masonry
Riverbed scour repairs
Gabion repairs
Repair of parapets, marker posts, safety barriers and features/signs
Painting
Structural repairs to the following defects:
▪ Structural timber decay, splitting or insect attack
▪ Bulging masonry
▪ Cracked concrete or masonry
▪ Honeycombed concrete
▪ Spalling concrete
▪ Serious rust or chemical stains
▪ Exposed or corroding reinforcement or pre-stressing steel
▪ Damp patches on the concrete
▪ Seriously corroded structural steelwork
▪ Damaged/distorted structural steelwork
▪ Loose structural rivets, bolts or other fixings
▪ Cracks in structural steelwork
▪ Settlement of deck, piers, abutments or wingwalls
▪ Expansion joint or bearing defects
▪ Erosion requiring piling works.

## 7.4 Common Structure Maintenance Requirements

### 7.4.1 Scour

Damage due to scour and erosion is the most common cause of major or unrepairable damage to a structure. Once scour or erosion around a structure starts, the damage can increase very rapidly. It is therefore essential that maintenance is carried out promptly to prevent further structural damage.

### 7.4.2 Drifts

The drift must maintain a firm roadway across the width of the river, which is not covered by debris or eroded by the flood water. The face of the river embankments should also be protected against scour and erosion. It may be possible to encourage the growth of vegetation along the banks to improve the bank stability and prevent erosion. The common maintenance issues to address are:

- Cracking of the slab;
- Undercutting on the downstream side;
- Erosion at ends of slab where it is not extended above high flood levels;
- Lack of downstream protection; and
- Guidestones knocked off.

### 7.4.3 Culverts

The most common maintenance problem associated with culverts is blockage due to silt and other debris. Hence regular cleaning of the culverts is essential. A blocked culvert can result in damage to the road in three ways:

- Water can seep into the subgrade of the road and reduce its strength - the road may subside, and the road surface will break up.
- The water can undermine the head and wingwall of the culvert causing it to collapse - the road embankment will then be unsupported and rapidly subside.
- In an extreme case the water level may continue to increase until the water floods over the road. The road may then become impassable and major damage occur as the water erodes the road and culvert. Ultimately the road will be washed away, and a large gully will be scoured across the road.

Water discharging from culverts with excessive velocity will erode the stream bed and possibly undermine the whole structure. It is therefore essential to provide some form of protection to the ground immediately below the outlet of a culvert. The protection is usually in the form of a masonry or gabion apron. It may also be necessary to prevent erosion of the watercourse downstream of the culvert. Bio-engineering planting may be an appropriate and low-cost solution.

The main cause of blockage of culverts is by water carried debris and vegetation. Larger debris tends to collect at the entrance to the culvert causing blockage at the headwall, while silt is deposited in and upstream from the culvert. If unchecked this silt can build up until it fills the culvert opening. Long grass at the outlet of a culvert can cause silting at the outlet and eventual blockage of the culvert. It is therefore necessary, particularly before the rainy season, to clean culvert barrels, inlets and outlets to allow water to flow freely through the culvert.



**Figure E.7.1: Box culvert partially blocked by vegetation**

Any material removed from a culvert should be disposed of downstream of the culvert to prevent it washing back into the structure. Other common defects that require maintenance to be carried out on culverts include:

- Downstream erosion;
- Headwall knocked down or damaged;
- Outfall channel eroded or silted;
- Undercutting of the culvert outfall apron; and
- Ponding of water at the inlet and/or outlet causing subsidence of the road embankment.

#### **7.4.4 Vented Drifts and Large Bore Culverts**

The common maintenance requirements with vented fords and large bore culverts are similar to culverts and drifts. In addition to the issues discussed above the following defects may need to be corrected during maintenance:

- floating debris, such as tree branches, can block the culvert barrels;
- cracking and breaking of roadway slab; and
- cracking and breaking of structure faces.





**Figure E.7.2: Cleaning the drop inlet and barrel of a large bore culvert**

#### 7.4.5

#### Bridge maintenance

The substantially larger investment in bridges, compared to smaller structures, justifies greater attention to inspection and maintenance of these vital road components. The consequences of failure due to lack of maintenance can be complete loss of access for a considerable period with serious adverse social and economic outcomes. It is therefore important to establish a regime of regular bridge inspections and active maintenance response works.

Inspections should be carried out annually to identify and initiate maintenance repairs for the following defects:

- Minor Defects (non-structural):
  - Accumulation of dirt or soil on bridge deck;
  - Blocked scuppers;
  - Stones, soil or dirt in joints or around bearings;
  - Vegetation or soil in weep holes or in backfill drainage outlets;
  - Flood debris at or under bridge; and
  - Wind-blown debris on or under bridge.
- Minor Defects (structural):
  - Loose or missing nailed/bolted connectors or fixings;
  - Damaged running boards or deck planks;
  - Rusty steel, faded paint;
  - Untreated wood; and
  - Defective masonry joints.
- Minor Defects (Safety):
  - Damaged safety barrier or parapet; and
  - Damaged warning signs.

The following defects may require major repair works and specialist expertise to ensure appropriate remedial works. The inspection system should initiate mobilisation of the necessary expertise when these defects are identified:

- Major Defects:
  - Scour adjacent to structure;
  - Structural timber decay, splitting or insect attack;
  - Bulging masonry;
  - Cracked concrete or masonry;
  - Honeycombed concrete;

- Spalling concrete;
- Serious rust or chemical stains;
- Exposed or corroding reinforcement;
- Damp patches on the concrete;
- Seriously corroded structural steelwork;
- Damage/distorted structural steelwork;
- Loose structural rivets, bolts or other fixings;
- Cracks in structural steelwork;
- Settlement of deck, piers or abutments;
- Erosion requiring piling works; and
- Vehicle Impact damage (particularly to steel panel bridges).

Further guidance on bridge and structures maintenance is available from the PIARC International Road Maintenance Handbook Volume IV. Guidance on the inspection of bridges can be found in the Transport and Road Research Laboratory, Overseas Road Note 7, Volume 2 “Bridge Inspector’s Handbook”.

## APPENDIX E.1: SPECIFICATIONS FOR MAINTENANCE OF LOW VOLUME ROADS

### CODING & MEASUREMENT SYSTEM

Each defect has a corresponding maintenance activity with the same code. The measurement of each item shall include for full compensation, for labor, materials, tools, supervision, equipment or transport and incidental costs required to carry out the work. Measurement shall be by the units shown.

### SUMMARY OF ACTIVITIES

CODE	ACTIVITY	MEASUREMENT UNIT
	<b>Roadside activities</b>	
1-01	Inspection of the road	km
1-02	Removal of obstructions	No
2-01a	Grass Cutting (Manual)	m <sup>2</sup>
2-01b	Grass Cutting (Mechanized)	m <sup>2</sup>
2-02	Bush clearing and tree removal	m <sup>2</sup>
2-03	Grubbing	m <sup>2</sup>
3-01a	Plant grass by seeding	m <sup>2</sup>
3-01b	Plant grass by turfing	m <sup>2</sup>
	<b>Drainage activities</b>	
4-01	Culvert/Drift Cleaning	No.
5-01	Drain cleaning (manual)	m
5-02	Drain cleaning (mechanized)	m
6-01	Construct or replace stone or wooden scour check	No.
6-02	Stone masonry drain lining	m
6-03	Concrete drain lining	m
7-01	Repair erosion damage (rock fill)	m <sup>3</sup>
7-02	Gabion check dam	m <sup>3</sup>
	<b>Retaining walls and road furniture</b>	
8-01	Gabion structure repair	m <sup>3</sup>
9-01	Mortared masonry repair	m <sup>3</sup>
10-01	Dry masonry repair	m <sup>3</sup>
11-01	Clean road sign	No.
11-02	Replace road sign	No.
	<b>Earth road carriageway maintenance</b>	
12-01	Reshape and compact earth road camber (labor-based)	m
12-02	Reshape and compact earth road camber (equipment-based)	m

CODE	ACTIVITY	MEASUREMENT UNIT
	Gravel road carriageway maintenance	
13-01	Spot repair to carriageway using selected material	m <sup>3</sup>
14-01	Light reshaping (manual)	m
14-02	Light reshaping (mechanized)	m
15-01	Grading gravel road (heavy)	m
16-01	Tire dragging	m
	Paved road routine maintenance	
17-01	Pothole or spot repair (sealed road)	m <sup>2</sup>
17-02	Pothole or spot repair (un-mortared stone or brick)	m <sup>2</sup>
17-03	Pothole or spot repair (mortared stone or brick)	m <sup>2</sup>
17-04	Edge break repair (sealed road)	m <sup>3</sup>
17-05	Crack sealing	m
18-01	Shoulder grading (mechanized)	m <sup>2</sup>
	Periodic maintenance	
19-01	Shoulder repair (manual)	m <sup>2</sup>
19-02	Shoulder repair (mechanized)	m <sup>2</sup>
20-01	Regravelling	m <sup>3</sup>
21-01	Reseal the road	m <sup>2</sup>
22-01	Replace road markings	m

## SPECIFICATIONS

1-01	ACTIVITY
	Inspection of the road
<b>Scope of works: Regular inspection of the road for any obstacles.</b>	
<p><b>Specifications:</b></p> <ul style="list-style-type: none"> <li>▪ Inspect the road twice a month.</li> <li>▪ Travel by any available means along entire section length and take observations across formation width and drainage system.</li> <li>▪ Obtain regular information from road users on whether the carriageway is blocked.</li> <li>▪ Record the type and extent of any blockages or obstacles on the road.</li> </ul> <p><b>Description of bill item:</b></p> <p><b>1-01</b> The unit of measurement shall be the length of road inspected in km.</p>	
1-02	ACTIVITY
	Removal of obstructions
<b>Scope of works: Removal of any object causing obstruction to normal traffic movement or causing danger or discomfort to road users or interfering with normal functioning of any of the road elements or features.</b>	
<p><b>Specifications:</b></p> <ul style="list-style-type: none"> <li>▪ Dead animals: Locate area out of formation width and within road reserve but free from garden or roadside development. Excavate pit 1m deep. Use disposable hand gloves to remove and carry dead animal to excavated pit and bury it and the used gloves. Backfill and compact.</li> <li>▪ Fallen trees: Use power-saw or chainsaw to chop into movable pieces. Carry or roll off the formation width and deposit into road reserve which is free from road side developments and away from drainage system. Avoid damage to road structure, road surface or other road elements during rolling of cut pieces.</li> <li>▪ Boulders (greater than 30cm diameter): Use crow bars and timber rollers to push boulders off the road formation to the lower side taking advantage of gravity and slope. Make good any damage to the road surface while rolling boulder. Support or bed the boulder in a stable position to avoid possible rolling and damage to people or property downhill.</li> </ul> <p><b>Description of bill item:</b></p> <p><b>1-02</b> The unit of measurement shall be the number of objects removed from the road and disposed of in accordance with the specification.</p>	



2-01	ACTIVITY
	Grass cutting
<p><b>Scope of works: Cutting of grass and shrubs along the roadside to improve visibility along the road, on curves and to avoid obstruction of road signs, or concealing stray animals or pedestrians near to or crossing the road.</b></p>	
<p><b>2-01a Grass Cutting (Manual)</b></p> <p><b>Specifications:</b></p> <ul style="list-style-type: none"> <li>▪ Place warning signs and safety devices.</li> <li>▪ Cut all grass evenly to a height of a maximum of 10cm above the ground level and to the required width from the edge of the road.</li> <li>▪ Grass shall generally be cut while facing away from the road so that any flying objects due to the slashing are not thrown onto the carriageway.</li> <li>▪ Increase the width of the road side cut on the inside of curves to ensure good visibility.</li> <li>▪ Clear all cut grass, from the road carriageway, drains ditch and from inlets and outlets of drainage structures and dispose in a safe place away from the road.</li> <li>▪ Collect and safely dispose of any litter or debris on the roadside.</li> <li>▪ <b>DO NOT BURN</b> the grass cut along the road or the debris removed after maintenance.</li> <li>▪ Measure and record the total length and width of road side cut.</li> <li>▪ Remove the temporary signs and safety devices.</li> </ul> <p><b>2-01b Grass Cutting (Equipment)</b></p> <p><b>Specifications:</b></p> <ul style="list-style-type: none"> <li>▪ Place warning signs and safety devices.</li> <li>▪ Cut grass to a maximum height of 10cm above the ground level and to the required width from the edge of the road.</li> <li>▪ Mow grass using tractor drawn mower or hand-held sickle power mower to level ground free from obstruction from debris.</li> <li>▪ Cut grass in ditches, and areas round fixed road furniture by hand.</li> <li>▪ Rake and load onto trailer/truck to designated disposal sites. <b>BURNING OF GRASS</b> is not allowed.</li> <li>▪ Clear the carriageway, drains, turn-out drains, inlet and outlet of drainage structures of any debris and litter and dispose of safely.</li> <li>▪ Measure and record total length and width of road side mowed.</li> <li>▪ Remove all temporary signs and safety devices.</li> </ul> <p><b>Unit of measurement:</b></p> <p><b>2-01</b> The unit of measurement shall be the area of grass cut in m<sup>2</sup>.</p>	

2-02	ACTIVITY
	Bush clearing and tree removal
<b>Scope of works: Improve visibility to maintain safe sight distance, visibility of road signs, road markers, animals and pedestrians within the road reserve.</b>	
<p><b>Specifications:</b></p> <ul style="list-style-type: none"> <li>▪ Place warning signs and safety devices.</li> <li>▪ Cut, uproot and remove bushes and trees to ensure that all bushes and trees are cleared.</li> <li>▪ Cut tree branches overhanging the road so that a minimum 4.5m clearance is obtained.</li> <li>▪ Workmen must ensure that no damage is caused to fixed objects such as road furniture when removing debris and cut or uprooted during clearing.</li> <li>▪ Backfill and compact to density of surrounding ground all excavated holes dug during removal of roots.</li> <li>▪ Collect and clear all cut roots and debris from drains, carriageway and road reserve, load and dispose to designated sites.</li> <li>▪ Measure and record the length and width of area cleared.</li> <li>▪ Remove temporary road signs and safety devices.</li> </ul> <p><b>Unit of measurement:</b></p> <p><b>2-02</b> The unit of measurement shall be the area of bush and trees cleared in m<sup>2</sup>.</p>	
2-03	ACTIVITY
	Grubbing
<b>Scope of works: Improve drainage of the road surface by grubbing vegetation growing on the edge of the road or shoulder</b>	
<p><b>Specifications:</b></p> <ul style="list-style-type: none"> <li>▪ Place warning signs and safety devices.</li> <li>▪ Remove grass growing along the edge of road using a hoe, without removing excessive material from the road shoulder.</li> <li>▪ Do not remove grass growing on the edge of the road that does not impede the flow of water off the road.</li> <li>▪ Collect and clear all cut grass and roots and debris from drains, carriageway and road reserve, load and dispose to designated sites.</li> <li>▪ Measure and record the length and width of area grubbed.</li> <li>▪ Remove temporary road signs and safety devices.</li> </ul> <p><b>Unit of measurement:</b></p> <p><b>2-03</b> The unit of measurement shall be the area of grubbing carried out m<sup>2</sup>.</p>	

3-01	ACTIVITY
	Plant grass
<b>Scope of works: Control slope erosion damage by planting grass.</b>	
<p><b>Specifications:</b></p> <ul style="list-style-type: none"> <li>▪ Place warning signs and safety devices.</li> <li>▪ Mark areas to be planted.</li> <li>▪ Import top soil to improve quality of in situ material and lightly compact.</li> </ul> <p><b>3-01a Seeding</b></p> <ul style="list-style-type: none"> <li>▪ Loosen the soil to a depth of 10 cm in the area to be seeded using rakes or similar tools.</li> <li>▪ Spread the topsoil to a depth of at least 5 cm.</li> <li>▪ Apply fertilizer at the specified rate, if directed.</li> <li>▪ Apply ground limestone at the specified rate and mix in, if directed</li> <li>▪ Apply seeds by hand at the specified rate.</li> <li>▪ Lightly roll the seeded area within 24 hours using hand roller, only if the soil does not adhere to the roller.</li> <li>▪ The seeded area should be watered as required until the grass has taken hold.</li> </ul> <p><b>3-01b Seedlings/Turfing</b></p> <ul style="list-style-type: none"> <li>▪ Trim the grass to be planted into slips of 20 to 30cm and plant them in the V ditch with edge of ditch line slightly uphill forming a U shape.</li> <li>▪ Water immediately after planting</li> <li>▪ Space the slips 10 to 15 cm apart</li> <li>▪ Spacing of the lines of seedlings should not exceed 0.5m</li> <li>▪ Clear the site of left over plants and trimmings</li> <li>▪ Measure and record area planted</li> <li>▪ Remove temporary signs and safety devices.</li> </ul> <p><b>Unit of measurement:</b></p> <p><b>3-01</b> The unit of measurement shall be the area planted with grass in m<sup>2</sup>.</p>	

4-01	ACTIVITY
	Culvert/drift cleaning
<b>Scope of works: Removal of silt, debris or excess vegetation blocking or interfering with the smooth flow of water into, through and out of drainage structures.</b>	
<p><b>Specifications:</b></p> <ul style="list-style-type: none"> <li>▪ Place warning signs and safety devices.</li> <li>▪ Culvert to be cleared of all silt and debris. Culvert inlets and outlets to be cleared of vegetation and silt to a length of 5m on both sides of the culvert.</li> <li>▪ The inlet and outlet trenches to have a bottom width of 400mm more than the culvert diameter, and the trench sides to have a slope of 1:1, or flatter in fine sandy type material.</li> <li>▪ Material and debris from the culvert/drift must be spread or dumped where they cannot wash back into the watercourse and cause an obstruction to water flow, preferably on the downstream side of the culvert, well away from the watercourse.</li> <li>▪ Remove temporary signs and safety devices.</li> </ul> <p><b>Unit of measurement:</b></p> <p><b>4-01</b> The unit of measurement shall be number of culverts or drifts cleaned.</p>	

5-01	ACTIVITY
	Drain cleaning (manual)
<b>Scope of works: Clear side and turn-out drains of all obstacles interfering with flow of water.</b>	
<p><b>Specifications:</b></p> <ul style="list-style-type: none"> <li>▪ Place warning signs and safety devices.</li> <li>▪ Remove all the silt and debris in the drains using hand labor.</li> <li>▪ Dig out any undesirable vegetation growing in the drains.</li> <li>▪ Ensure that all the cleared silt and debris is placed well clear of the drain to avoid washing back and blocking the drains when it rains.</li> <li>▪ Measure the length of drain cleared.</li> <li>▪ Clean up the area and remove temporary signs and safety devices.</li> </ul> <p><b>Unit of measurement:</b></p> <p><b>5-01</b> The unit of measurement shall be the length of drains cleared in metres.</p>	

5-02	ACTIVITY
	Drain cleaning (mechanized)
<b>Scope of works: Cleaning of side drain and turn-out drain and removing silt and debris.</b>	
<p><b>Specifications:</b></p> <ul style="list-style-type: none"> <li>▪ Place warning signs and safety devices.</li> <li>▪ Clear all silt and debris from the side drains using the edge of the grader blade.</li> <li>▪ Flatten the windrow on the top outer side of the drain and clear all loose material.</li> <li>▪ Measure the drain width and length and record the measurements.</li> <li>▪ Remove traffic control signs and safety devices.</li> </ul> <p><b>Unit of measurement:</b></p> <p><b>5-02</b> The unit of measurement shall be the length of drains cleared in metres.</p>	

6-01	ACTIVITY
	<b>Construct or replace stone or wooden scour check</b>
<b>Scope of works: Control erosion damage on side drains by constructing scour checks.</b>	
<p><b>Specifications:</b></p> <ul style="list-style-type: none"> <li>▪ Place warning signs and safety devices.</li> <li>▪ New scour checks shall be constructed across the full width of the drain affected by erosion.</li> <li>▪ The spacing of scour checks varies according to soil type and gradient of the drain.</li> <li>▪ Shape the damaged drain to restore the original shape of the drain.</li> <li>▪ The gradient of the side drain should be checked with an Abney level or line and level to determine the requirements for scour checks (spacing guidance in the LVR Design Manual).</li> <li>▪ Scour checks should not normally be constructed on drains with gradients of less than 2%. This would encourage too much silting of the drain and could lead to road damage.</li> <li>▪ The scour checks must not be too high otherwise water will be forced onto the surrounding ground, the shoulder or the roadway. The scour checks construction should therefore be controlled with the aid of a template.</li> <li>▪ After the basic scour check has been constructed, an apron should be built immediately downstream either using stones or grass sods pinned to the drain invert with wooden pegs. The apron will help resist the forces of the water flowing over the scour checks. Grass sods should be placed against the upstream face of the scour checks, to prevent water seeping through the scour checks and to encourage the silting behind the scour checks. The long-term objective is to establish complete grass cover over the silted scour checks to stabilize them</li> <li>▪ Water the new vegetation until established.</li> <li>▪ Clear loose material and count and record number of scour checks repaired/constructed.</li> </ul> <p><b>Unit of measurement:</b>  <b>6-01</b> The unit of measurement shall be number of scour checks constructed.</p>	
6-02	ACTIVITY
	<b>Stone masonry lining to drain</b>
<b>Scope of works: Control erosion of side drains by lining the drain with mortared stone pitching.</b>	
<p><b>Specifications:</b></p> <ul style="list-style-type: none"> <li>▪ Place warning signs and safety devices.</li> <li>▪ Shape the damaged drain to restore the original shape of the drain using the ditch template.</li> <li>▪ The stones must be sound, tough and durable, and with a minimum dimension of 200 mm.</li> <li>▪ Clean the stones of dirt or clay.</li> <li>▪ Moistened the stones and embed them in freshly laid cement mortar composed of one part of cement to six parts of sand.</li> <li>▪ Fill the spaces between the stones with cement grout of the same composition as the mortar. Work the grout into the pitching to ensure that all spaces or voids between the stones are completely filled with grout to the full depth of the stone pitching.</li> <li>▪ The mortar and grout must be placed in a continuous operation on the same day.</li> <li>▪ Remove any grout spilt onto the exposed surfaces of the stone while it is still soft.</li> <li>▪ Neatly finish the joints between the stones.</li> <li>▪ Cure the grouted pitching with wet sacking or other wet cover for a period of not less than four days after grouting.</li> <li>▪ Clear loose material and tidy the site.</li> <li>▪ Measure and record the area of mortared stone pitching constructed.</li> </ul> <p><b>Unit of measurement:</b>  <b>6-02</b> The unit of measurement shall be the area of mortared stone pitching constructed in m<sup>2</sup>.</p>	



6-03	ACTIVITY
	Concrete lining to drain
<b>Scope of works: Control erosion of side drains by lining the drain with concrete.</b>	
<p><b>Specifications:</b></p> <ul style="list-style-type: none"> <li>▪ Place warning signs and safety devices.</li> <li>▪ Shape the damaged drain to restore the original shape of the drain using the ditch template.</li> <li>▪ Fix formwork to the required lines and levels to enable the concrete to be laid in alternate panels or maximum 3 metre length.</li> <li>▪ Water the surface prior to placing the concrete.</li> <li>▪ The concrete must have a minimum strength of 20 MPa.</li> <li>▪ The thickness of the concrete shall conform with the thickness shown on the drawings or specified by the Engineer <math>\pm 10\text{mm}</math>.</li> <li>▪ If mesh reinforcing is specified it shall be placed in the center of the depth of the concrete using approved non-porous cover blocks.</li> <li>▪ Compact the concrete and finish it with a wood float.</li> <li>▪ Cure the concrete for at least seven days with wet sacking or other wet cover.</li> <li>▪ Clear loose material and tidy the site.</li> <li>▪ Measure and record area of concrete lining constructed.</li> </ul> <p><b>Unit of measurement:</b></p> <p><b>6-03</b> The unit of measurement shall be the area of concrete lining constructed in m<sup>2</sup>.</p>	

7-01	ACTIVITY
	Repair erosion damage (rock fill)
<b>Scope of works: Repair of erosion damage on road shoulders, slopes and drain using rock fill.</b>	
<p><b>Specifications:</b></p> <ul style="list-style-type: none"> <li>▪ Place warning signs and safety devices.</li> <li>▪ Measure the area to be repaired and record the width, length and depth of the damaged area.</li> <li>▪ Place all rocks individually with the broad side on the bottom starting with the bigger rocks and filling gages with medium and small ones interlocking and minimizing void space.</li> <li>▪ Place the smaller rocks to form a filter.</li> <li>▪ Avoid placing rocks on the carriageway or too close to the road.</li> <li>▪ Clear the area of left over rock and debris.</li> <li>▪ Remove traffic control signs and safety devices.</li> </ul> <p><b>Unit of measurement:</b></p> <p><b>7-01</b> The unit of measurement shall be the volume of rock fill used for the repair in cubic metres.</p>	

7-02	ACTIVITY
	Gabion check dam
<b>Scope of works: Construction of gabion check dams across eroded gullies to control and repair erosion damage.</b>	
<p><b>Specifications:</b></p> <ul style="list-style-type: none"> <li>▪ Place warning signs and safety devices if the works are close to the road.</li> <li>▪ Excavate a firm and level foundation trench for the gabions across the gully with a minimum depth of 300mm below the bottom of the gully.</li> <li>▪ Provide benches in the foundation trench at the sides of the gully - the height and length of the benches shall correspond with the size of the gabion baskets.</li> <li>▪ Prepare the gabion baskets in a regular shape with all sides straight and symmetrical.</li> <li>▪ Place each gabion against a firm excavated wall or next to another gabion basket.</li> <li>▪ Secure the gabions by tying them to the adjacent gabion(s)</li> <li>▪ Fit bracing ties as necessary.</li> <li>▪ Fill the gabion basket manually with hard durable stones no larger than 25 cm but no smaller than the size of the mesh wire forming the gabion.</li> <li>▪ Pack the stones tightly against each other to form a solid structure.</li> <li>▪ Slightly overfill the basket to allow for settlement of the stones.</li> <li>▪ Firmly secure the lid to the sides using tying wire.</li> <li>▪ The vertical joints in the gabion wall must be staggered from one layer of gabions to the next.</li> <li>▪ Provide a spillway in the center of the gabion wall to contain the flow of water.</li> <li>▪ Remove all loose debris and tidy the site.</li> <li>▪ Measure and record the volume of gabions constructed.</li> <li>▪ Remove warning signs signage.</li> </ul> <p><b>Unit of measurement:</b></p> <p><b>7-02:</b> The unit of measurement shall be volume of gabions constructed in cubic metres.</p>	

8-01	ACTIVITY
	Gabion structure repair
<b>Scope of works: Repair damaged gabion baskets and reinstate.</b>	
<p><b>Specifications:</b></p> <ul style="list-style-type: none"> <li>▪ Place warning signs and safety devices</li> <li>▪ Dismantle damaged gabion and clear the site for repair</li> <li>▪ Measure the area and volume of work required to make good the damaged extent of gabions</li> <li>▪ Shape the gabion basket into a regular shape with all sides straight and symmetrical</li> <li>▪ Place gabion against a firm excavated wall or next to an existing gabion basket</li> <li>▪ Secure the gabion by tying it to the adjacent gabion(s)</li> <li>▪ Fit bracing ties as necessary</li> <li>▪ Fill the gabion basket manually with hard durable stones no larger than 25 cm but no smaller than the size of the mesh wire forming the gabion</li> <li>▪ Pack the stones tightly against each other to form a solid structure - slightly overfill the basket</li> <li>▪ Firmly secure the gabion lid to the sides using tying wire.</li> <li>▪ Remove all loose debris and signage.</li> </ul> <p><b>Unit of measurement:</b></p> <p><b>8-01</b> The unit of measurement shall be volume of gabion repaired in cubic metres.</p>	

9-01	ACTIVITY
	Mortared masonry repair
<b>Scope of works: Repair of damaged section of mortared masonry works and re-instate the structure to as close as possible to its original condition.</b>	
<p><b>Specifications:</b></p> <ul style="list-style-type: none"> <li>▪ Place warning signs and safety devices.</li> <li>▪ Measure the area to be repaired and record the width, length and depth of the damaged area.</li> <li>▪ Remove damaged stone work and clear rubble, and then prepare the surface.</li> <li>▪ Excavate the trench for any foundations required down to rock or firm ground to a minimum depth of 300mm.</li> <li>▪ Prepare cement mortar 1 part cement to four parts pit sand for use during the placing of rocks. The mortar shall be prepared in quantities that can be used within an hour.</li> <li>▪ Place mortar on the bottom of the trench and lay stones in the bed of mortar 10 - 40mm thick</li> <li>▪ Select and place stones adjacent to each other with mortar between them, ensuring regular joint width.</li> <li>▪ Clean all exposed surfaces of excess mortar.</li> <li>▪ Cure the mortar using wet sacking for a minimum of seven days from the day of repair works</li> <li>▪ Clear site of loose materials.</li> <li>▪ Remove traffic control signs and safety devices.</li> </ul> <p><b>Unit of measurement:</b></p> <p><b>9-01:</b> The unit of measurement shall be the volume of masonry repaired in cubic metres.</p>	

10-01	ACTIVITY
	Dry masonry repair
<b>Scope of works: Repair of damaged section of dry masonry works and re- instate the structure to as close as possible to its original condition.</b>	
<p><b>Specifications:</b></p> <ul style="list-style-type: none"> <li>▪ Place warning signs and safety devices</li> <li>▪ Measure the area to be repaired and record the width, length and depth of the damaged area</li> <li>▪ Remove damaged stone work and clear rubble, and then prepare the surface</li> <li>▪ Excavate the trench for any foundations required down to rock or firm ground to a minimum depth of 300mm</li> <li>▪ Lay shaped stones neatly packing them on a bedding of sand</li> <li>▪ Wedge joints with smaller chips to secure stones in place and fill in the voids with sand to restrain movement</li> <li>▪ Construct edges and top with mortared stone to restrain movement of packed stones.</li> <li>▪ Clear site of left over stones and debris</li> <li>▪ Remove traffic control signs and safety devices.</li> </ul> <p><b>Unit of measurement:</b></p> <p><b>10-01</b> The unit of measurement shall be the volume of masonry repaired in cubic metres.</p>	

<b>11-01</b>	<b>ACTIVITY</b>
	<b>Clean dirty road sign</b>
<b>Scope of works: Clean Dirty Road Sign</b>	
<p><b>Specifications:</b></p> <ul style="list-style-type: none"> <li>▪ Place warning signs and safety devices.</li> <li>▪ Clean sign face using cloth, water and detergent solution.</li> <li>▪ Remove all traces of detergent with a cloth and soft brush and rinse with water.</li> <li>▪ Clean the back of the sign and the supporting structure using water and cloth.</li> <li>▪ Remove dirt from corners of fittings.</li> <li>▪ Count and record the number and type of road signs cleaned.</li> <li>▪ Tidy up the site and remove all traffic signs and safety devices.</li> </ul> <p><b>Unit of measurement:</b></p> <p><b>11-01</b> The unit of measurement shall be number of signs cleaned.</p>	
<b>11-02</b>	<b>ACTIVITY</b>
	<b>Replace road sign</b>
<b>Scope of works: Replace defective road sign</b>	
<p><b>Specifications:</b></p> <ul style="list-style-type: none"> <li>▪ Place warning signs and safety devices</li> <li>▪ Remove the defective sign and post as directed</li> <li>▪ Supply and erect new sign and post as directed and to national specifications</li> <li>▪ Tidy up the site and remove all traffic control signs and safety devices.</li> </ul> <p><b>Unit of measurement:</b></p> <p><b>11-03</b> The unit of measurement shall be number of signs replaced.</p>	
<b>12-01</b>	<b>ACTIVITY</b>
	<b>Reshape and compact earth road camber (labor-based)</b>
<b>Scope of works: Repair damaged earth road surface and reshape camber using labor.</b>	
<p><b>Specifications:</b></p> <ul style="list-style-type: none"> <li>▪ Place warning signs and safety devices.</li> <li>▪ Set out the centre line of the road and the edge of the carriageway including horizontal and vertical curves.</li> <li>▪ Mark out the side drains with pegs and string lines.</li> <li>▪ Excavate the drains as a rectangular shaped trench and throw the excavated material on to the road surface.</li> <li>▪ Excavate the front slope and the back slope of the drain and use the ditch template to ensure the correct shape for the drain; throw the excavated material onto the road.</li> <li>▪ Set out the camber for the road using pegs and string lines.</li> <li>▪ If the loose material on the road is dry, water it with a towed water bowser.</li> <li>▪ Spread the loose material on the road to establish the road formation.</li> <li>▪ Check the camber using the camber board.</li> <li>▪ Compact the road surface until the roller makes no further indentation in the surface or a specified density is achieved.</li> <li>▪ Remove traffic control signs and safety devices.</li> </ul> <p><b>Unit of measurement:</b></p> <p><b>12-01</b> Unit of measurement shall be the length of earth road reshaped in metres.</p>	

12-02	ACTIVITY
	<b>Reshape and compact earth road camber (equipment-based)</b>
<b>Scope of works: Repair damaged earth road surface and reshape camber using equipment.</b>	
<p><b>Specifications:</b></p> <ul style="list-style-type: none"> <li>▪ Place warning signs and safety devices</li> <li>▪ Scarify the existing surface to cut to the bottom of any surface defects and loosen the material for reshaping.</li> <li>▪ Work the grader on one side of the road at a time in passes about 200 metres long to convenient and safe turning points.</li> <li>▪ Complete the work on one side of the road at a time with an even number of passes to avoid a flat finished crown.</li> <li>▪ Initially bring material in from the edges of the road and then redistribute the material away from the crown.</li> <li>▪ If the material is dry spray the windrow with water before spreading the windrow back across the road.</li> <li>▪ Apply a second application of water to achieve the correct moisture content for compaction.</li> <li>▪ Check the camber using a camber board.</li> <li>▪ Compact the road surface until the roller makes no further indentation in the surface or a specified density is achieved.</li> <li>▪ Remove traffic control signs and safety devices.</li> </ul> <p><b>Unit of measurement:</b></p> <p><b>12-02</b> Unit of measurement shall be the length of earth road reshaped in metres.</p>	

13-01	ACTIVITY
	<b>Spot repair to carriageway with selected material</b>
<b>Scope of works: Repair of potholes, ruts and soft spots on gravel road surface using selected gravel material.</b>	
<p><b>Specifications:</b></p> <ul style="list-style-type: none"> <li>▪ Place warning signs and safety devices.</li> <li>▪ Excavate and shape the hole to a depth of 75 -100mm minimum. Measure the excavated hole and record the measurements.</li> <li>▪ Remove any debris, standing water and loose material or mud.</li> <li>▪ Obtain selected gravel material meeting national specifications to gravel wearing course.</li> <li>▪ Add water to the gravel to achieve optimum moisture content.</li> <li>▪ Backfill the gravel material in layers of 10cm and compact using a hand rammer or plate compactor.</li> <li>▪ Remove any surplus material and tidy up the area</li> <li>▪ Remove traffic control signs and safety devices.</li> </ul> <p><b>Unit of measurement:</b></p> <p><b>13-01</b> Unit of measurement shall be the volume of material placed and compacted in m<sup>3</sup>.</p>	



14-01	ACTIVITY
	Light re-shaping (manual method)
<b>Scope of works: Reshaping the road using manual means to reduce roughness, improve riding quality and maintain camber</b>	
<p><b>Specifications:</b></p> <ul style="list-style-type: none"> <li>▪ Place warning signs and safety devices.</li> <li>▪ Loosened, trim and reshaped the surface with a pickaxe, hoe or mattock and rakes to form the required camber and crossfall.</li> <li>▪ Check the camber with the camber board and spirit level.</li> <li>▪ Fill any local depressions with approved gravel material.</li> <li>▪ Measure the length of road reshaped and record the measurements.</li> <li>▪ Remove traffic signs and safety devices.</li> </ul> <p><b>Unit of measurement:</b></p> <p><b>14-01</b> The unit of measurement shall be the length of reshaping in metres.</p>	
14-02	ACTIVITY
	Light re-shaping (mechanized method)
<b>Scope of works: Grading of the road using mechanical means to reduce roughness, improve riding quality and maintain camber</b>	
<p><b>Specifications:</b></p> <ul style="list-style-type: none"> <li>▪ Place warning signs and safety devices.</li> <li>▪ Grading should begin from one side of the road and progress across to the other side of the road leaving the windrow on one side. Cutting passes should be a maximum of 5cm deep. The windrow is then re-spread to the correct camber.</li> <li>▪ On average four passes across the road are sufficient to provide a smooth riding surface on a 4 to 5m carriageway.</li> <li>▪ On completion clear all loose stones and windrows from the carriageway.</li> <li>▪ Measure the lengths of road maintained and record the measurements.</li> <li>▪ Remove traffic signs and safety devices.</li> </ul> <p><b>Unit of measurement:</b></p> <p><b>14-02</b> The unit of measurement shall be the length of reshaping in metres.</p>	

15-01	ACTIVITY
	Grade gravel road carriageway (heavy)
<b>Scope of works: Mechanical grading, scarify and move the material into a windrow and then mix with water and spread into required profile and compact.</b>	
<p><b>Specifications:</b></p> <ul style="list-style-type: none"> <li>▪ Place warning signs and safety devices.</li> <li>▪ Rip and scarify the existing road surface and push into a windrow towards the center of the road.</li> <li>▪ If the material is dry spray the windrow with water before spreading the windrow back across the road.</li> <li>▪ Remove loose stones and windrows from the carriageway.</li> <li>▪ Spread the material and compact forming the required profile; check the camber using the camber board.</li> <li>▪ Apply a second application of water to achieve the correct moisture content for compaction.</li> <li>▪ Compact the road surface until the roller makes no further indentation in the surface or a specified density is achieved.</li> <li>▪ Remove traffic signs and safety devices.</li> </ul> <p><b>Unit of measurement:</b></p> <p><b>15-01</b> The unit of measurement shall be the length of heavy reshaping in metres.</p>	

16-01	ACTIVITY
	Tire dragging
<b>Scope of works: Use of a tire drag towed by a tractor or a truck to reduce roughness, improve riding quality and retard the development of corrugations</b>	
<p><b>Specifications:</b></p> <ul style="list-style-type: none"> <li>▪ Place warning signs and safety devices.</li> <li>▪ Tow the drag at up to 5 km/hour.</li> <li>▪ Tow the drag in the same direction as the traffic flow covering both sides of the road.</li> <li>▪ Measure the length of road maintained.</li> <li>▪ Remove traffic signs and safety devices.</li> </ul> <p><b>Unit of measurement:</b></p> <p><b>16-01</b> The unit of measurement shall be the length of road dragged in metres.</p>	

17-01	ACTIVITY
	<b>Pothole or spot repair (sealed road)</b>
<b>Scope of works: Repair of a damaged area or pothole in a sealed road</b>	
<p><b>Specifications:</b></p> <ul style="list-style-type: none"> <li>▪ Place warning signs and safety devices.</li> <li>▪ Clean the area thoroughly using a broom.</li> <li>▪ Trim the hole into a regular rectangular shape with level base.</li> <li>▪ Fill the hole with approved selected material allowing extra fill for settlement after compaction.</li> <li>▪ Moisten and compact thoroughly with a hand rammer or plate compactor.</li> <li>▪ Apply bitumen binder to the repaired area at the required rate of spread (bitumen emulsion or heated bitumen).</li> <li>▪ Immediately apply approved aggregate material to the area sprayed with bitumen.</li> <li>▪ Lightly roll the patch until the aggregate is embedded in the binder or (in the case of emulsion) after the emulsion has 'broken'.</li> <li>▪ Tidy up the area of loose material.</li> <li>▪ Remove traffic control signs and safety devices.</li> </ul> <p><b>Unit of measurement:</b></p> <p><b>17-01</b> The unit of measurement shall be the area of the repair in square metres.</p>	

17-02	ACTIVITY
	<b>Pothole or spot repair (unmortared stone or brick)</b>
<b>Scope of works: Repair damaged section of road with un-mortared stone or brick surface.</b>	
<p><b>Specifications:</b></p> <ul style="list-style-type: none"> <li>▪ Place warning signs and safety devices.</li> <li>▪ Remove damaged stones or bricks.</li> <li>▪ Remove the bedding and expose the damaged area.</li> <li>▪ Level the base and moisten then compact.</li> <li>▪ Re-lay the bedding to original thickness.</li> <li>▪ Re-lay new stones or bricks to fill the hole.</li> <li>▪ Spread fine sand over the laid stones or bricks to fill the joints and ensure interlocking.</li> <li>▪ Tamp the stones or bricks with a hammer to pack properly.</li> <li>▪ Clean up loose material and left-over sand.</li> <li>▪ Remove traffic control signs and safety devices.</li> </ul> <p><b>Unit of measurement:</b></p> <p><b>17-02</b> The unit of measurement shall be the area of the repair in square metres.</p>	

17-03	ACTIVITY
	Pothole or spot repair (mortared stone or brick)
<b>Scope of works: Repair damaged section of mortared stone or brick.</b>	
<p><b>Specifications:</b></p> <ul style="list-style-type: none"> <li>▪ Place warning signs and safety devices.</li> <li>▪ Remove damaged stones and bricks and clear the site for repair.</li> <li>▪ Measure the area of work required to make good the damaged area.</li> <li>▪ Sprinkle some water on the cleared area and compact.</li> <li>▪ Prepare mortar comprising one part cement to four parts pit sand and place on the base area to be repaired.</li> <li>▪ Place clean stones or bricks on the mortar bedding adjacent to each other with mortar in between them to bond.</li> <li>▪ Clean the stones or bricks of excess mortar remove all loose material and dirt.</li> <li>▪ Remove traffic control signs and safety devices.</li> </ul> <p><b>Unit of measurement:</b></p> <p><b>17-03</b> The unit of measurement shall be the area of the repair in square metres.</p>	

17-04	ACTIVITY
	Edge break repair (sealed road)
<b>Scope of works: Repair of edge break to a bitumen sealed road using premix asphalt</b>	
<p><b>Specifications:</b></p> <ul style="list-style-type: none"> <li>▪ Place warning signs and safety devices.</li> <li>▪ Mark the edge of the repair with a straight line.</li> <li>▪ Break the damaged area back to the marked line and to a minimum depth of 50mm.</li> <li>▪ Clean the area of rubble, dirt, dust and chips.</li> <li>▪ Prepare hot or cold-mix asphalt concrete to the required mix proportions.</li> <li>▪ Place the asphalt against the marked line to reinstate the edge of the road.</li> <li>▪ Compact the asphalt using hand rammers or compaction equipment.</li> <li>▪ Remove traffic control signs and safety devices.</li> </ul> <p><b>Unit of measurement:</b></p> <p><b>17-04</b> The unit of measurement shall be the volume of asphalt used in the repair in cubic metres.</p>	

17-05	ACTIVITY
	Crack sealing (sealed road)
<b>Scope of works: Repair of cracks in the surface of a bitumen sealed</b>	
<p><b>Specifications:</b></p> <ul style="list-style-type: none"> <li>▪ Place warning signs and safety devices to close the section of road to traffic.</li> <li>▪ Clean out the cracks with a broom and air from a tire pump or compressor.</li> <li>▪ Fill the cracks with an approved cut-back bitumen or bitumen emulsion. For wider cracks mix fine sand into the binder.</li> <li>▪ Pour the liquid into the crack using a watering can and push the liquid into the crack using a squeegee shaped into a vee.</li> <li>▪ Sprinkle the surface of the binder with dry sand or quarry dust.</li> <li>▪ Remove traffic control signs and safety devices and reopen the road to traffic.</li> </ul> <p><b>Unit of measurement:</b></p> <p><b>17-05</b> The unit of measurement shall be the length of cracks sealed in metres.</p>	

18-01	ACTIVITY
	Shoulder grading (mechanized)
<b>Scope of works: Repair of minor erosion damage to restore efficient drainage and improve road safety.</b>	
<p><b>Specifications:</b></p> <ul style="list-style-type: none"> <li>▪ Place warning signs and safety devices.</li> <li>▪ Mark areas to be repaired.</li> <li>▪ Scarify the area using a towed grader or other authorised equipment.</li> <li>▪ Moisten the area if the material is dry.</li> <li>▪ Spread the material to the correct cross fall to ensure good drainage.</li> <li>▪ Compact material to the same density as the surrounding ground or to a density specified by the Engineer using a motorized roller or hand operated compactor.</li> <li>▪ Measure and record the area repaired</li> <li>▪ Tidy up the area and remove temporary signs and safety devices.</li> </ul> <p><b>Unit of measurement:</b></p> <p><b>18-01</b> The unit of measurement shall be in the area of shoulder/slope area repaired in m<sup>2</sup>.</p>	



19-01	ACTIVITY
	Shoulder repair (manual)
<b>Scope of works: Repair of major erosion damage on road shoulder and slopes.</b>	
<p><b>Specifications:</b></p> <ul style="list-style-type: none"> <li>▪ Place warning signs and safety devices.</li> <li>▪ Mark areas to be repaired by indenting on the ground eroded areas.</li> <li>▪ Scarify with a pick, shovel hoe etc. to depth of minimum 100mm</li> <li>▪ Moisten the area if material is dry.</li> <li>▪ Add material of similar composition/specification if required to the existing and add water to obtain optimum moisture content.</li> <li>▪ Spread the material to the correct cross fall to ensure good drainage.</li> <li>▪ Compact the material to the same density as the surrounding ground or to a density specified by the Engineer.</li> <li>▪ Check that the finished cross fall complies with the specification requirements.</li> <li>▪ Measure and record the area repaired.</li> <li>▪ Tidy up the area and remove temporary signs and safety devices.</li> </ul> <p><b>Unit of measurement:</b></p> <p><b>19-01</b> The unit of measurement shall be the area of shoulder/slope repaired in m<sup>2</sup>.</p>	

19-02	ACTIVITY
	Shoulder repair (mechanized)
<b>Scope of works: Repair major erosion damage on road shoulder and slopes.</b>	
<p><b>Specifications:</b></p> <ul style="list-style-type: none"> <li>▪ Place warning signs and safety devices.</li> <li>▪ Mark areas to be repaired.</li> <li>▪ Scarify using a towed grader or other authorised equipment to depth of the erosion damage</li> <li>▪ Moisten the area if material is dry.</li> <li>▪ Add material of similar composition/specification if required to the existing and add water to obtain optimum moisture content.</li> <li>▪ Blade mix and spread the material to the correct cross fall to ensure good drainage.</li> <li>▪ Compact material to the same density as the surrounding ground or to a density specified by the Engineer using a motorized roller or hand operated compactor.</li> <li>▪ Check that the finished cross fall complies with the specification requirements.</li> <li>▪ Measure and record the area repaired.</li> <li>▪ Tidy up the area and remove temporary signs and safety devices.</li> </ul> <p><b>Unit of measurement:</b></p> <p><b>19-02</b> The unit of measurement shall be in the area of shoulder/slope area repaired in m<sup>2</sup>.</p>	

20-01	ACTIVITY
	Regravelling with selected material
<b>Scope of works: Re-gravelling of road section involving bringing in additional natural gravel to supplement existing layer, water, mix and compact.</b>	
<p><b>Specifications:</b></p> <ul style="list-style-type: none"> <li>▪ Place warning signs and safety devices.</li> <li>▪ Provide a detour for use by traffic during re gravelling exercise or arrange suitable traffic control.</li> <li>▪ Repair any localised damage on the subgrade or pavement before re gravelling (14-01).</li> <li>▪ Scarify existing gravel layer to ensure bond with new material.</li> <li>▪ Bring in additional approved gravel and dump along the road at specified intervals to obtain the desired final thickness.</li> <li>▪ Spread, water and mix the gravel then form the surface into required camber or cross fall.</li> <li>▪ Clear all oversize stones and loose windrows.</li> <li>▪ Remove traffic control signs and safety devices.</li> </ul> <p><b>Unit of measurement:</b></p> <p><b>20-01</b> The unit of measurement shall be the volume of gravel placed and compacted in m<sup>3</sup>.</p>	

21-01	ACTIVITY
	Reseal the road
<b>Scope of works: Reseal a bituminous paved road with a specified thin bituminous seal.</b>	
<p><b>Specifications:</b></p> <ul style="list-style-type: none"> <li>▪ Place warning signs and safety devices.</li> <li>▪ Repair all potholes and other defects in the road surface (measured under 18-01).</li> <li>▪ Brush all loose material off the road.</li> <li>▪ Wash the road surface with water and stiff brooms.</li> <li>▪ Spray the approved binder on to the road surface at the specified application rate and in accordance with the manufacturer's guidelines using a hand lance or mechanical bitumen distributor.</li> <li>▪ Spread approved aggregate on the road surface at the specified application rate either by hand application or mechanical aggregate spreader.</li> <li>▪ Roll the surface with a pneumatic tired roller to bring the binder up through the aggregate and create a tight mosaic.</li> <li>▪ Avoid longitudinal joints or minimise them by adjusting the width of the spray bar to that the number of passes of the bitumen distributor is the same as the number of traffic lanes. Adjust the spray bar to leave a 10 – 15 cm wide edge with less binder, which is left uncovered by aggregate. The edge is then overlapped with the following pass of the bitumen distributor before covering with aggregate.</li> <li>▪ Apply additional heavy rolling to even out the longitudinal joints and the built up ridge caused by bitumen over-spray.</li> <li>▪ Construct transverse joints using start and finishing sheets with the end of the previous section blinded off to make an accurate starting line for the new section. Transverse joints should never be placed on top of each other and they should be staggered by approximately 50 metres along the road.</li> <li>▪ Carry out follow-up inspections of the sprayed surfacing work to correct any defects that may have occurred during the sealing operation.</li> <li>▪ Tidy up the site and remove all traffic control signs and safety devices.</li> </ul> <p><b>Unit of measurement:</b></p> <p><b>21-01</b> The unit of measurement shall be the area of road surface resealed in m<sup>2</sup>.</p>	

22-01	ACTIVITY
	Replace road markings
<b>Scope of works: Replace road markings that are worn or covered due to resealing the road.</b>	
<p><b>Specifications:</b></p> <ul style="list-style-type: none"> <li>▪ Place warning signs and safety devices.</li> <li>▪ Approved retro-reflective road-marking paint shall be used for all road markings. The paint shall be delivered at the site in sealed containers bearing the name of the manufacturer and the type of paint. The viscosity of the paint shall be such that it can be applied without being thinned.</li> <li>▪ Before the paint is applied, the surface shall be clean and dry and completely free from any soil, grease, oil, acid or any other material which will be detrimental to the bond between the paint and the surface.</li> <li>▪ Road markings shall be applied to bituminous surfaces only after sufficient time has elapsed to ensure that damage will not be caused to the painted surface by volatiles evaporating from the surfacing.</li> <li>▪ The lines shall be pre-marked by means of paint spots of the same colour as that of the final lines. These paint spots shall be no more than 1.5 m apart.</li> <li>▪ After spotting, the positions of the road markings shall be approved by the Engineer prior to commencing any painting operations.</li> <li>▪ The paint shall be stirred before application in accordance with the manufacturer's instructions. Paint shall be applied without the addition of thinners.</li> <li>▪ Where the paint is applied by machine, it shall be applied in one layer. The satisfactory operation of the machine shall be demonstrated on a suitable site away from the permanent works.</li> <li>▪ Where painting is done by hand, it shall be applied in two layers, and the second layer shall not be applied before the first layer has dried. As most road-marking paint reacts with the bitumen surface of the road, the paint shall be applied with one stroke only of the brush or roller.</li> </ul> <p>Tidy up the site and remove all traffic control signs and safety devices.</p> <p><b>Unit of measurement:</b></p> <p><b>22-01</b> The unit of measurement shall be the length of lines painted on the road surface in m.</p>	

## APPENDIX E.2: REFERENCES AND FURTHER ADVICE

### Documentation

The following documents and publications may be accessed for further information. Many of these documents may be accessed or downloaded free of charge from the ReCAP website.

1. Gongera, K. and Petts, R. A Tractor and Labour Based Routine Maintenance System for Unpaved Rural Roads. Intech Associates. Second Edition, June 2003.
2. ILO, Guide to Tools and Equipment for Labour Based Road Construction, 1981.
3. Intech Associates & MOPW Kenya, Road Maintenance Manual, 1992.
4. I&D Consult & MOPW Kenya, Headman's Handbook for Maintenance, 1991.
5. Transport and Road Research Laboratory, Overseas Road Note 1, Road Maintenance Management for District Engineers, 2003.
6. Transport and Road Research Laboratory, Overseas Road Note 7, Volume 2, Bridge Inspector's Handbook, 1988.
7. World Road Association (PIARC), International Road Maintenance Handbook, 4 Volumes, 1994 and revisions.

## APPENDIX E.3: ROAD INVENTORY DATA COLLECTION FORM

### Road Inventory Data Collection Form

ROAD AGENCY NAME:   
 COUNTY:  ASSESSOR:  DATE:

---

**ROAD AND SECTION DETAILS:**

ROAD NAME: <input style="width: 200px;" type="text"/> TRAFFIC: <input style="width: 50px;" type="text"/> ROAD NO.: <input style="width: 50px;" type="text"/> <input style="width: 50px;" type="text"/> ROAD START POINT: <input style="width: 150px;" type="text"/> Km START POINT COORD: X <input style="width: 50px;" type="text"/> Y <input style="width: 50px;" type="text"/>  Section Name: <input style="width: 200px;" type="text"/> Section Start Point: <input style="width: 150px;" type="text"/> Km Start Point Coords: X <input style="width: 50px;" type="text"/> Y <input style="width: 50px;" type="text"/>	<table border="1" style="width: 100%; text-align: center; border-collapse: collapse;"> <tr> <td>1</td><td>2</td><td>3</td><td>4</td><td>4</td></tr> <tr> <td>&lt;20</td><td>20-50</td><td>50-100</td><td>100-200</td><td>&gt;200</td></tr> </table> ROAD END POINT: <input style="width: 150px;" type="text"/> Km END POINT COORD: X <input style="width: 50px;" type="text"/> Y <input style="width: 50px;" type="text"/>  Road Reserve Avg Width: <input style="width: 50px;" type="text"/> m Section End Point: <input style="width: 150px;" type="text"/> Km End Point Coords: X <input style="width: 50px;" type="text"/> Y <input style="width: 50px;" type="text"/>	1	2	3	4	4	<20	20-50	50-100	100-200	>200
1	2	3	4	4							
<20	20-50	50-100	100-200	>200							

---

**INVENTORY DATA:**

<b>Vert. Alignment:</b> <table border="1" style="width: 100%; text-align: center; border-collapse: collapse;"> <tr> <td>Flat</td><td>Rolling</td><td>Steep</td></tr> <tr> <td><input style="width: 30px;" type="text"/></td><td><input style="width: 30px;" type="text"/></td><td><input style="width: 30px;" type="text"/></td></tr> </table>	Flat	Rolling	Steep	<input style="width: 30px;" type="text"/>	<input style="width: 30px;" type="text"/>	<input style="width: 30px;" type="text"/>	<b>Horizontal Alignment:</b> <table border="1" style="width: 100%; text-align: center; border-collapse: collapse;"> <tr> <td>S/Curves</td><td>Gentl Curves</td><td>Straight</td></tr> <tr> <td><input style="width: 30px;" type="text"/></td><td><input style="width: 30px;" type="text"/></td><td><input style="width: 30px;" type="text"/></td></tr> </table>	S/Curves	Gentl Curves	Straight	<input style="width: 30px;" type="text"/>	<input style="width: 30px;" type="text"/>	<input style="width: 30px;" type="text"/>	<b>Vegetation:</b> <table border="1" style="width: 100%; text-align: center; border-collapse: collapse;"> <tr> <td>Grass</td><td>L/Bush</td><td>H/Bush</td></tr> <tr> <td><input style="width: 30px;" type="text"/></td><td><input style="width: 30px;" type="text"/></td><td><input style="width: 30px;" type="text"/></td></tr> </table>	Grass	L/Bush	H/Bush	<input style="width: 30px;" type="text"/>	<input style="width: 30px;" type="text"/>	<input style="width: 30px;" type="text"/>
Flat	Rolling	Steep																		
<input style="width: 30px;" type="text"/>	<input style="width: 30px;" type="text"/>	<input style="width: 30px;" type="text"/>																		
S/Curves	Gentl Curves	Straight																		
<input style="width: 30px;" type="text"/>	<input style="width: 30px;" type="text"/>	<input style="width: 30px;" type="text"/>																		
Grass	L/Bush	H/Bush																		
<input style="width: 30px;" type="text"/>	<input style="width: 30px;" type="text"/>	<input style="width: 30px;" type="text"/>																		

<b>Pavement Surface Types:</b> <table border="1" style="width: 100%; text-align: center; border-collapse: collapse;"> <tr> <td>1</td><td>2</td><td>3</td><td>4</td><td>5</td></tr> <tr> <td>Earth</td><td>Gravel</td><td><input style="width: 30px;" type="text"/></td><td><input style="width: 30px;" type="text"/></td><td><input style="width: 30px;" type="text"/></td></tr> </table>	1	2	3	4	5	Earth	Gravel	<input style="width: 30px;" type="text"/>	<input style="width: 30px;" type="text"/>	<input style="width: 30px;" type="text"/>	<b>Pavement Material Types:</b> <table border="1" style="width: 100%; text-align: center; border-collapse: collapse;"> <tr> <td>1</td><td>2</td><td>3</td><td>4</td><td>5</td></tr> <tr> <td>Clay/Silt</td><td>Sandy Clay</td><td>Sand</td><td>Gravel</td><td>Stoney Gravel</td></tr> </table>	1	2	3	4	5	Clay/Silt	Sandy Clay	Sand	Gravel	Stoney Gravel
1	2	3	4	5																	
Earth	Gravel	<input style="width: 30px;" type="text"/>	<input style="width: 30px;" type="text"/>	<input style="width: 30px;" type="text"/>																	
1	2	3	4	5																	
Clay/Silt	Sandy Clay	Sand	Gravel	Stoney Gravel																	

<b>Pavement Surface Type &amp; Width:</b> Chainage: <table border="1" style="width: 100%; border-collapse: collapse;"> <thead> <tr> <th>From</th><th>To</th><th>Type</th><th>Width (m)</th></tr> </thead> <tbody> <tr><td> </td><td> </td><td> </td><td> </td></tr> <tr><td> </td><td> </td><td> </td><td> </td></tr> <tr><td> </td><td> </td><td> </td><td> </td></tr> <tr><td> </td><td> </td><td> </td><td> </td></tr> <tr><td> </td><td> </td><td> </td><td> </td></tr> <tr><td> </td><td> </td><td> </td><td> </td></tr> <tr><td> </td><td> </td><td> </td><td> </td></tr> <tr><td> </td><td> </td><td> </td><td> </td></tr> <tr><td> </td><td> </td><td> </td><td> </td></tr> <tr><td> </td><td> </td><td> </td><td> </td></tr> </tbody> </table>	From	To	Type	Width (m)																																									<b>Pavement Material Type:</b> Chainage: <table border="1" style="width: 100%; border-collapse: collapse;"> <thead> <tr> <th>From</th><th>To</th><th>Type</th><th>Remark</th></tr> </thead> <tbody> <tr><td> </td><td> </td><td> </td><td> </td></tr> <tr><td> </td><td> </td><td> </td><td> </td></tr> <tr><td> </td><td> </td><td> </td><td> </td></tr> <tr><td> </td><td> </td><td> </td><td> </td></tr> <tr><td> </td><td> </td><td> </td><td> </td></tr> <tr><td> </td><td> </td><td> </td><td> </td></tr> <tr><td> </td><td> </td><td> </td><td> </td></tr> <tr><td> </td><td> </td><td> </td><td> </td></tr> <tr><td> </td><td> </td><td> </td><td> </td></tr> <tr><td> </td><td> </td><td> </td><td> </td></tr> </tbody> </table>	From	To	Type	Remark																																								
From	To	Type	Width (m)																																																																																						
From	To	Type	Remark																																																																																						

<b>Shoulder Type:</b> <table border="1" style="width: 100%; text-align: center; border-collapse: collapse;"> <tr> <td>None</td><td>Earth</td><td>Gravel</td></tr> <tr> <td>1</td><td>2</td><td>3</td></tr> </table>	None	Earth	Gravel	1	2	3	<b>Side Drain Type:</b> <table border="1" style="width: 100%; text-align: center; border-collapse: collapse;"> <tr> <td>None</td><td>Flat</td><td>V-Drain</td><td>Trapez</td></tr> <tr> <td>1</td><td>2</td><td>3</td><td>4</td></tr> </table>	None	Flat	V-Drain	Trapez	1	2	3	4
None	Earth	Gravel													
1	2	3													
None	Flat	V-Drain	Trapez												
1	2	3	4												

<b>Shoulder Type &amp; Width:</b> Chainage: <table border="1" style="width: 100%; border-collapse: collapse;"> <thead> <tr> <th>From</th><th>To</th><th>Type</th><th>L/R</th><th>Width(m)</th></tr> </thead> <tbody> <tr><td> </td><td> </td><td> </td><td> </td><td> </td></tr> <tr><td> </td><td> </td><td> </td><td> </td><td> </td></tr> <tr><td> </td><td> </td><td> </td><td> </td><td> </td></tr> <tr><td> </td><td> </td><td> </td><td> </td><td> </td></tr> <tr><td> </td><td> </td><td> </td><td> </td><td> </td></tr> <tr><td> </td><td> </td><td> </td><td> </td><td> </td></tr> <tr><td> </td><td> </td><td> </td><td> </td><td> </td></tr> <tr><td> </td><td> </td><td> </td><td> </td><td> </td></tr> <tr><td> </td><td> </td><td> </td><td> </td><td> </td></tr> <tr><td> </td><td> </td><td> </td><td> </td><td> </td></tr> </tbody> </table>	From	To	Type	L/R	Width(m)																																																			<b>Side Drain Type, Width, Depth:</b> Chainage: <table border="1" style="width: 100%; border-collapse: collapse;"> <thead> <tr> <th>From</th><th>To</th><th>Type</th><th>Width (m)</th></tr> </thead> <tbody> <tr><td> </td><td> </td><td> </td><td> </td></tr> <tr><td> </td><td> </td><td> </td><td> </td></tr> <tr><td> </td><td> </td><td> </td><td> </td></tr> <tr><td> </td><td> </td><td> </td><td> </td></tr> <tr><td> </td><td> </td><td> </td><td> </td></tr> <tr><td> </td><td> </td><td> </td><td> </td></tr> <tr><td> </td><td> </td><td> </td><td> </td></tr> <tr><td> </td><td> </td><td> </td><td> </td></tr> <tr><td> </td><td> </td><td> </td><td> </td></tr> <tr><td> </td><td> </td><td> </td><td> </td></tr> </tbody> </table>	From	To	Type	Width (m)																																								
From	To	Type	L/R	Width(m)																																																																																																
From	To	Type	Width (m)																																																																																																	

<b>Road Furniture:</b> <table border="1" style="width: 100%; border-collapse: collapse;"> <thead> <tr> <th>Chainage</th><th>Type</th><th>Remark</th><th>Chainage</th><th>Type</th><th>Remark</th></tr> </thead> <tbody> <tr><td> </td><td> </td><td> </td><td> </td><td> </td><td> </td></tr> <tr><td> </td><td> </td><td> </td><td> </td><td> </td><td> </td></tr> <tr><td> </td><td> </td><td> </td><td> </td><td> </td><td> </td></tr> <tr><td> </td><td> </td><td> </td><td> </td><td> </td><td> </td></tr> <tr><td> </td><td> </td><td> </td><td> </td><td> </td><td> </td></tr> <tr><td> </td><td> </td><td> </td><td> </td><td> </td><td> </td></tr> <tr><td> </td><td> </td><td> </td><td> </td><td> </td><td> </td></tr> <tr><td> </td><td> </td><td> </td><td> </td><td> </td><td> </td></tr> <tr><td> </td><td> </td><td> </td><td> </td><td> </td><td> </td></tr> <tr><td> </td><td> </td><td> </td><td> </td><td> </td><td> </td></tr> </tbody> </table>	Chainage	Type	Remark	Chainage	Type	Remark																																																													<b>Roadside Facilities:</b> <table border="1" style="width: 100%; border-collapse: collapse;"> <thead> <tr> <th>Chainage</th><th>Type</th><th>Remark</th></tr> </thead> <tbody> <tr><td> </td><td> </td><td> </td></tr> <tr><td> </td><td> </td><td> </td></tr> <tr><td> </td><td> </td><td> </td></tr> <tr><td> </td><td> </td><td> </td></tr> <tr><td> </td><td> </td><td> </td></tr> <tr><td> </td><td> </td><td> </td></tr> <tr><td> </td><td> </td><td> </td></tr> <tr><td> </td><td> </td><td> </td></tr> <tr><td> </td><td> </td><td> </td></tr> <tr><td> </td><td> </td><td> </td></tr> </tbody> </table>	Chainage	Type	Remark																														
Chainage	Type	Remark	Chainage	Type	Remark																																																																																															
Chainage	Type	Remark																																																																																																		











## APPENDIX E.7: STRUCTURE CONDITION ASSESSMENT FORM

Structures Condition Survey Form																																							
ROAD AGENCY NAME					STRUCTURE TYPE					NO.					LOCATION SKETCH																								
					CULVERT																																		
PROVINCE					DISTRICT																																		
INSPECTION INFORMATION																																							
Inspection Type:					Inspector					Firm										Date (dd/mm/yyyy)																			
GPS COORDINATES																																							
Start										End																													
LOCATION DETAILS																																							
Road No.		Road Name					Chainage (Km)			Feature Crossed				Feature Name																									
STRUCTURE INFORMATION																																							
No. of Openings		Type			Overall Length(m)					Overall Width(m)					Orientation																								
INSPECTION RATINGS																																							
INSPECTION ITEM					D					E					R																								
1. Approach Slabs & Cut Off Walls										5. Waterway																													
2. Wing/Retainer Headwalls										6. Roadway Slabs					9. Parapets/ Handrails																								
3. Scour Protection Works in Waterway										7. Roadway Joints					14. Miscellaneous																								
4. Embankments										8. Guardrails																													
INSPECTION ITEM					10. Walls					11. Top Slab					12. Invert Slab					13. Cell Displacement																			
Position					D					E					R					Position					D					E					R				
Cell																				Cell																			
Cell																				Cell																			
Cell																				Cell																			
Cell																				Cell																			
ACTION REQUIRED																																							
Item	Position	Activity										Qty	Unit	U	MS	Remarks										MF mths	Photos												
Inspector's overall assessment of structure condition and further comments:																																							
Structure Susceptible to Overtopping? Y//																																							
Further Inspection Needed? Y/N																																							
D - DEGREE							E - EXTENT							R - RELEVANCY						U - URGENCY																			
N/A	UA	Insp	None	Minor	Fair	Poor	Severe	Local	>Local	<Gnl	General	Min	Moderate	Major	Critical	Record	Monitor	Routine	< 5 yrs	< 2 yrs	ASAP																		
X	U		0	1	2	3	4	1	2	3	4	1	2	3	4	R	0	1	2	3	4																		



## APPENDIX E.8: ROAD MAINTENANCE SURVEY FORM

Road Agency Name: \_\_\_\_\_ County: \_\_\_\_\_ Reported By: \_\_\_\_\_ Date: \_\_\_\_\_

Road No: \_\_\_\_\_ Road Name: \_\_\_\_\_

Section Name: \_\_\_\_\_ Start Km: \_\_\_\_\_ End Km: \_\_\_\_\_

Code	Activity	Unit	Qty measured	Unit cost	Total cost
1-01	Inspection of the road	km			
1-02	Remove obstructions	No			
2-01	Grass cutting	m <sup>2</sup>			
2-02	Bush clearing and tree removal	m <sup>2</sup>			
2-03	Grubbing	m <sup>2</sup>			
3-01	Plant grass	m <sup>2</sup>			
4-01	Culvert/Drift Cleaning	No			
5-01/02	Drain Cleaning	m			
6-01	Construct or replace scour check	No			
6-02	Stone masonry lining	m			
6-03	Concrete lining	m			
7-01	Repair erosion damage (rockfill)	m <sup>3</sup>			
7-02	Gabion check dam	m <sup>3</sup>			
8-01	Gabion Structure Repair	m <sup>3</sup>			
9-01	Mortared Masonry Repair	m <sup>3</sup>			
10-01	Dry Masonry Repair	m <sup>3</sup>			
11-01	Clean Road Sign	No			
11-02	Replace road sign	No			
12-01/02	Reshape and compact Earth Road	m			
13-01	Spot Repair with selected material	m <sup>3</sup>			
14-01/02	Light reshaping	m			
15-01	Grading gravel road (heavy)	m			
16-01	Tyre dragging	m			
17-01	Pothole or Spot Repair (Sealed Road)	m <sup>2</sup>			
17-02	Pothole or Spot Repair (unmortared stone/brick)	m <sup>2</sup>			
17-03	Pothole or Spot Repair (mortared stone/brick)	m <sup>2</sup>			
17-04	Edge break repair	m <sup>3</sup>			
17-05	Crack sealing	m			
18-01	Shoulder grading	m <sup>2</sup>			
19-01	Shoulder repair	m <sup>2</sup>			