



ReCAP
Research for Community Access Partnership



Monitoring and Evaluation of Low Volume Roads Trial Sections in Kenya

Inception Report



Author

Eng. Ambrose Wafula Waswa

Institution

Across Africa Consultants Ltd.

*AFCAP Project Reference Number:
KEN2043C*

June, 2016

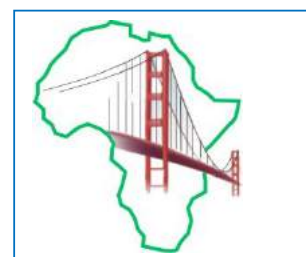

ACROSS AFRICA CONSULTANTS LTD.
HURLINGHAM PLAZA, 2ND FLOOR, SUITE C10
P.O. BOX 8272-00100
NAIROBI, KENYA
TEL: 020-214 963 95
CELL PHONE: +254 722 229 686
EMAIL: consultants.acrossafrica@gmail.com

The views in this document are those of the authors and they do not necessarily reflect the views of the Research for Community Access Partnership (ReCAP), or Cardno Emerging Markets (UK) Ltd for whom the document was prepared

Cover Photo:

<i>Quality assurance and review table</i>			
Version	Author(s)	Reviewer(s)	Date
1.0	Eng. Ambrose Wafula Waswa	Eng. Fredrick Muroki Gichuhi	03-06-2016

ReCAP Project Management Unit
Cardno Emerging Market (UK) Ltd
Oxford House, Oxford Road
Thame
OX9 2AH
United Kingdom



Project Details

ReCAP Database Details: [Monitoring and Evaluation of Low Volume Roads Trial Sections in Kenya]			
Reference No:	KEN2043C	Location	KENYA
Source of Proposal	ACROSS AFRICA CONSULTANTS LTD	Procurement Method	
Theme		Sub-Theme	
Lead Implementation Organisation	ReCAP	Partner Organisation	
Total Approved Budget	100,000 GBP	Total Used Budget	
Start Date	25 th May, 2016	End Date	31 st November, 2016
Report Due Date	3 rd June, 2016	Date Received	

Abstract

This report outlines the preliminary field activities undertaken by Across Africa Consultants Ltd since it was contracted by Cardno Emerging Markets, under the ReCAP Research Programme, for the project “Monitoring and Evaluation of Low Volume Roads Trial Sections in Kenya”. These include reconnaissance tour of all the sites, road marking, drainage assessment, visual inspection of the roads, installation of raingauges, and capacity building with AfCAP consultants and MTRD staff. With the knowledge gained from these activities, the consultant has been able to draft a sound activity schedule for both the baseline survey and the performance monitoring rounds. The consultant is now ready to embark on the actual field activities, namely traffic counts, axle load survey, roughness measurements, rut depth measurements, elastic modulus and pavement strength measurement, base layer moisture content determination, and carrying out the laboratory tests.

Key words

Low volume sealed roads, monitoring, evaluation

RESEACH FOR COMMUNITY ACCESS PARTNERSHIP (ReCAP)
Safe and sustainable transport for rural communities

ReCAP is a research programme, funded by UK Aid, with the aim of promoting safe and sustainable transport for rural communities in Africa and Asia. ReCAP comprises the Africa Community Access Partnership (AfCAP) and the Asia Community Access Partnership (AsCAP). These partnerships support knowledge sharing between participating countries in order to enhance the uptake of low cost, proven solutions for rural access that maximise the use of local resources. The ReCAP programme is managed by Cardno Emerging Markets (UK) Ltd.

See www.research4cap.org

Abbreviations and Acronyms

AFCAP	Africa Community Access Partnership
RECAP	Research for Community Access Partnership
UK	United Kingdom (of Great Britain and Northern Ireland)
MTRD	Materials Testing and Research Division
GoK	Government of Kenya
KeRRA	Kenya Rural Roads Authority
UKAid	United Kingdom Aid (Department for International Development, UK)

Contents

Project Details	ii
Abstract	ii
Key words	ii
Abbreviations and Acronyms	iv
1.0 Introduction	1
1.1 General	1
1.2 Project Description	1
1.3 Project Location	1
1.3.1 <i>Kiambu roads</i>	1
1.3.2 <i>Murang'a County roads</i>	3
1.3.3 <i>Nyeri County roads</i>	5
1.3.4 <i>Nyandarua County roads</i>	5
2.0 Mobilization – Preliminary field activities	7
2.1 Site visit	7
2.1.1 <i>Raingauge installation centres</i>	7
2.1.2 <i>Operational logistics</i>	7
2.1.3 <i>Source of labour</i>	8
2.1.4 <i>KeRRA regional offices</i>	8
2.1.5 <i>Site safety</i>	8
2.1.6 <i>Elements for close attention</i>	9
2.2 Desk studies	9
2.3 Preliminary Site Activities	9
2.3.1 <i>Raingauge installation</i>	10
2.3.2 <i>Road marking</i>	11
2.3.3 <i>Visual inspection</i>	18
3.0 Proposed Plan	19
3.1 Maintenance to D435	19
3.2 The Way Forward	19

1.0 Introduction

1.1 General

Across Africa Consultants Ltd was contracted to undertake the Monitoring and Evaluation of low volume roads trial sections in Kenya under the ReCAP research programme, whose main aim is to support research on utilization of non-standard materials for Low Volume Sealed Road pavements. The contract agreement was finalized and signed on 25th May, 2016. The consultant is to basically manage the carrying out of all the required tests.

The consultant is to submit the baseline survey report in August, 2016. The subsequent monitoring reports will be submitted in December 2016, July and December 2017, and July 2018. The final report will be submitted in October 2018.

1.2 Project Description

The Government of Kenya (GoK) is in the process of upgrading low volume rural roads to paved standards. Good construction material is increasingly getting scarce, and thus construction costs are becoming quite prohibitive, majorly because of the long haulage distances involved. An alternative would be to use non-standard materials for these low volume roads which carry up to 300 vehicles per day. This is what the research aims at, to provide performance based evidence which will contribute to the establishment of appropriate standards for Low Volume Sealed Roads in Kenya.

1.3 Project Location

The trial sections to be monitored are spread across 4 counties in Kenya, namely:

- Kiambu
- Murang'a
- Nyeri
- Nyandarua

1.3.1 *Kiambu roads*

The trial sections in Kiambu county include:

- Wamwang – Karatu Rd D379
- Kang'oo – Kamwangi Rd E1531
- Muruka – Kandara Rd D415

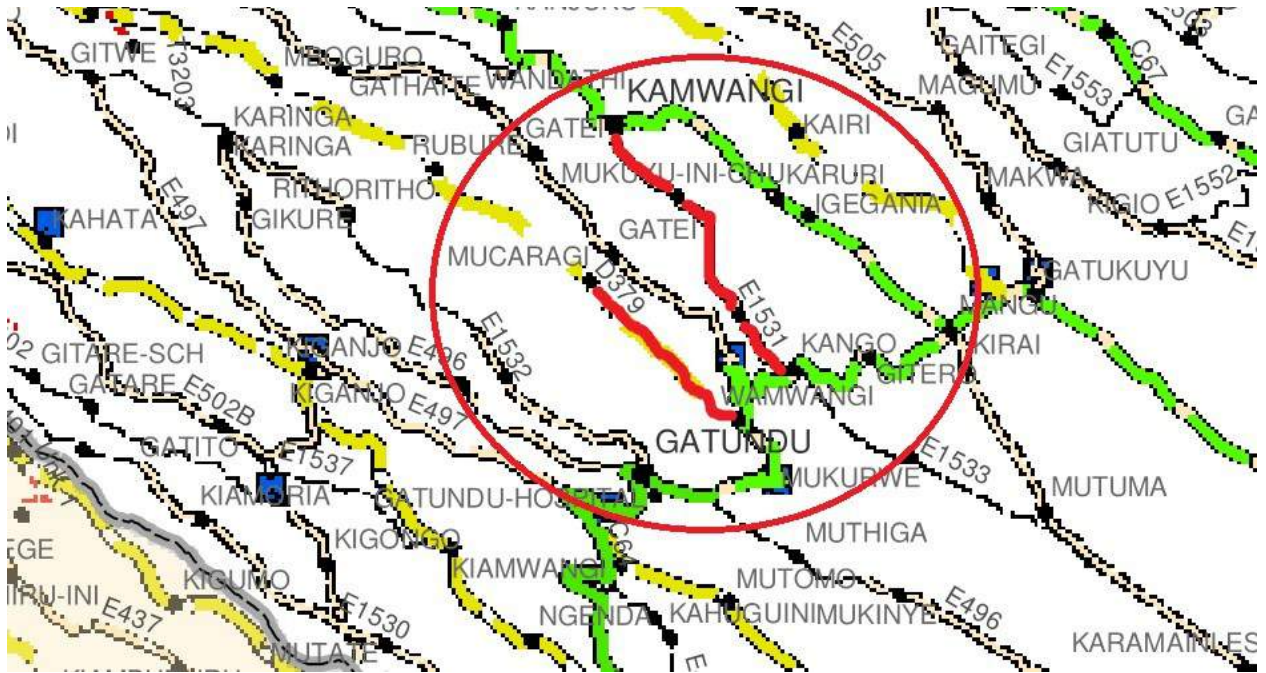

Figure 1: Map showing trial section D379 and E 1531

1.3.1.1 Wamwangi – Karatu Rd D379

This road starts at Wamwangi town centre, some 3 kilometres north of Gatundu town, and is 400 m long. Its construction was completed in the year 2012.

1.3.1.2 Kang’oo – Kamwangi Rd E1531

This trial section is located 4 km to the east of the above mentioned Wamwangi town centre. It starts at Kang’oo and ends at Kamwangi. Construction is currently underway, and thus its survey was amicably cancelled.

1.3.1.3 Muruka – Kandara Rd D415

This 7.5 km trial section starts at Makenzi town centre, passes through Muruka, and goes up to Kandara. Makenzi is just 5 km off road A2.

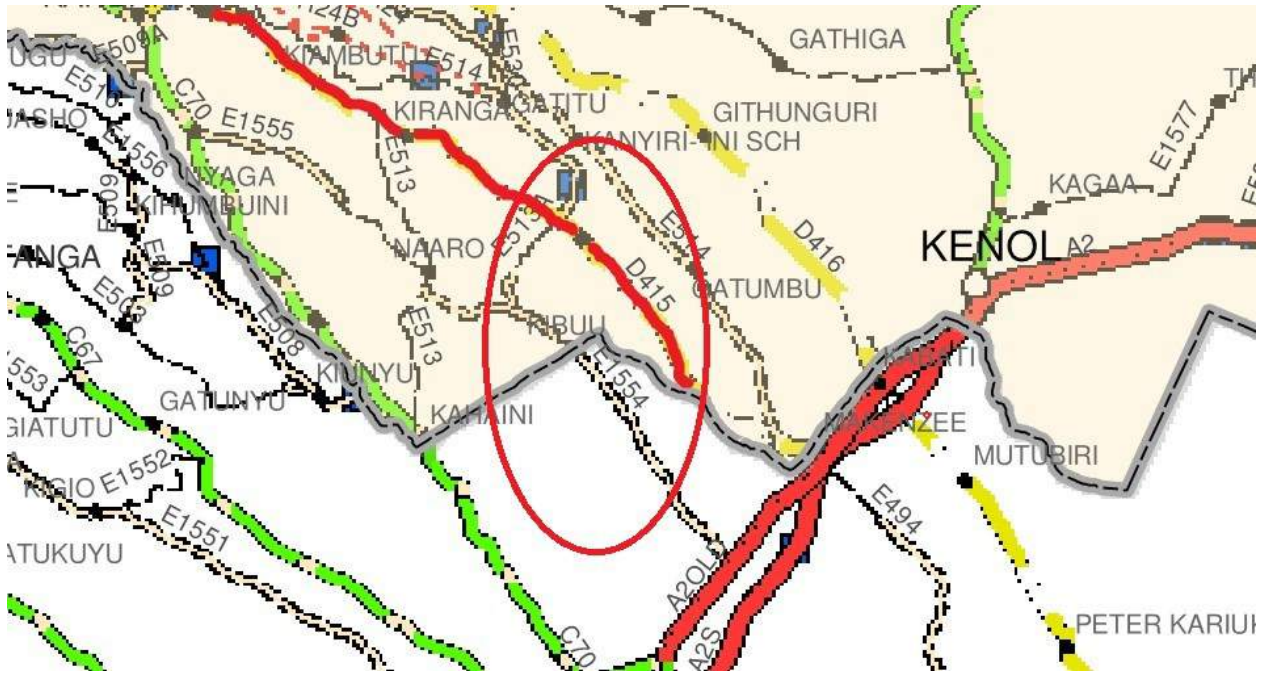

Figure 2: Map showing location of trial section D415 just off Road A2

1.3.2 Murang'a County roads

These include:

- Maragwa town – Gakiogo Jn Rd (D419)
- Karega – Gathara – Ithumbi Rd (D420)
- Gakiogo Jn – Maragua River Rd (D421)
- Kangure – Kinyona Rd (E511)

The first 3 are closely related as shown in the map below. Gakiogo junction is some 3 km from Maragua town.

D421 starts from this junction up to the river, totaling 3.3 km.

D419, starts right from Maragua town, goes past this junction, through Nginda, Irembu, Gikomora and ends at Ngaburi. The tarmacked section ends at Nginda, the rest is still earth road.

D420 starts at Nginda and goes through Ithumbu, Gathara, up to Karega, a total of 13.7 km.

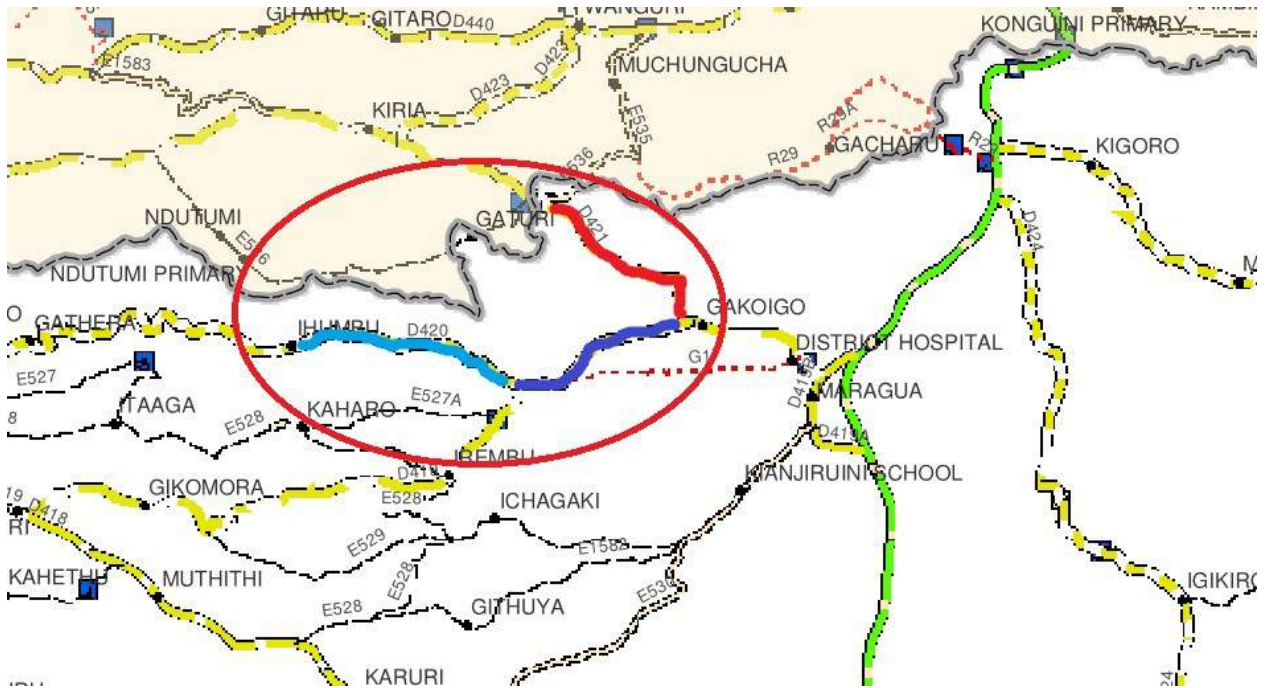

Figure 3: Map showing the interconnection between trial sections D419 (purple), D420 (blue) and D421 (red)

E511 is isolated from the rest as regards the location. It starts some 4 km from Kangari town centre, at some place called Mairi. It is 900 m in length.

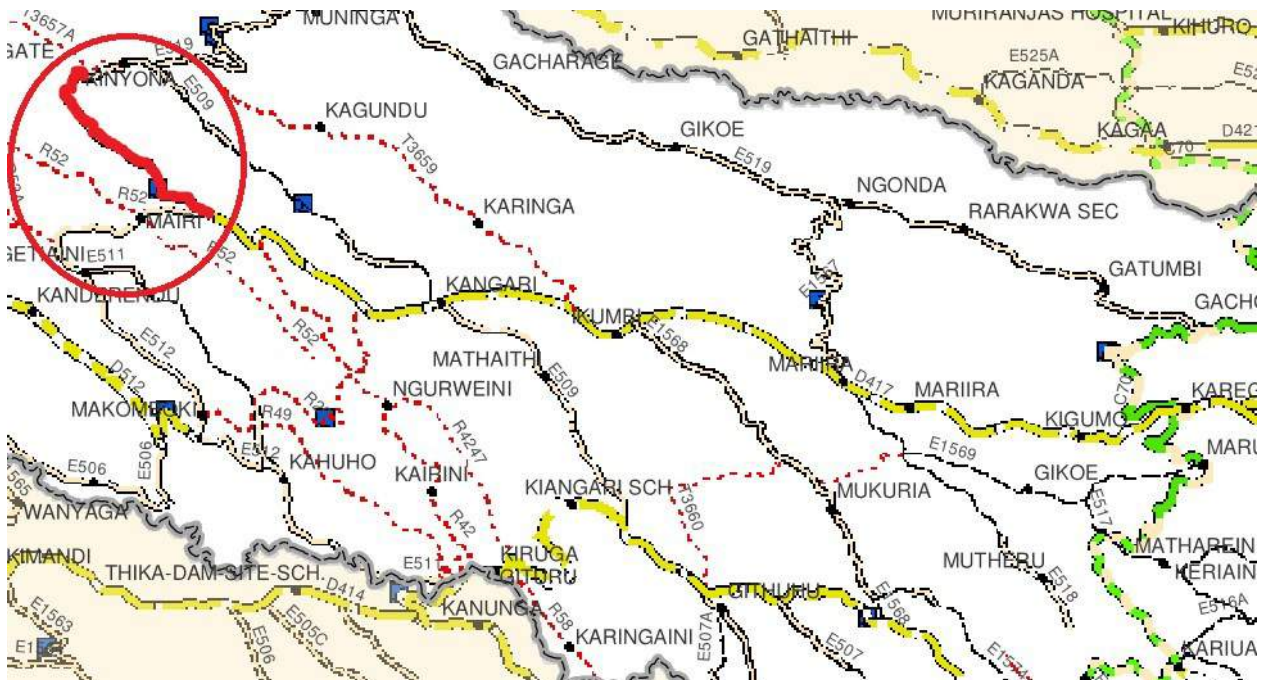

Figure 4: Map showing the location of E511 at some distance from Kangari town

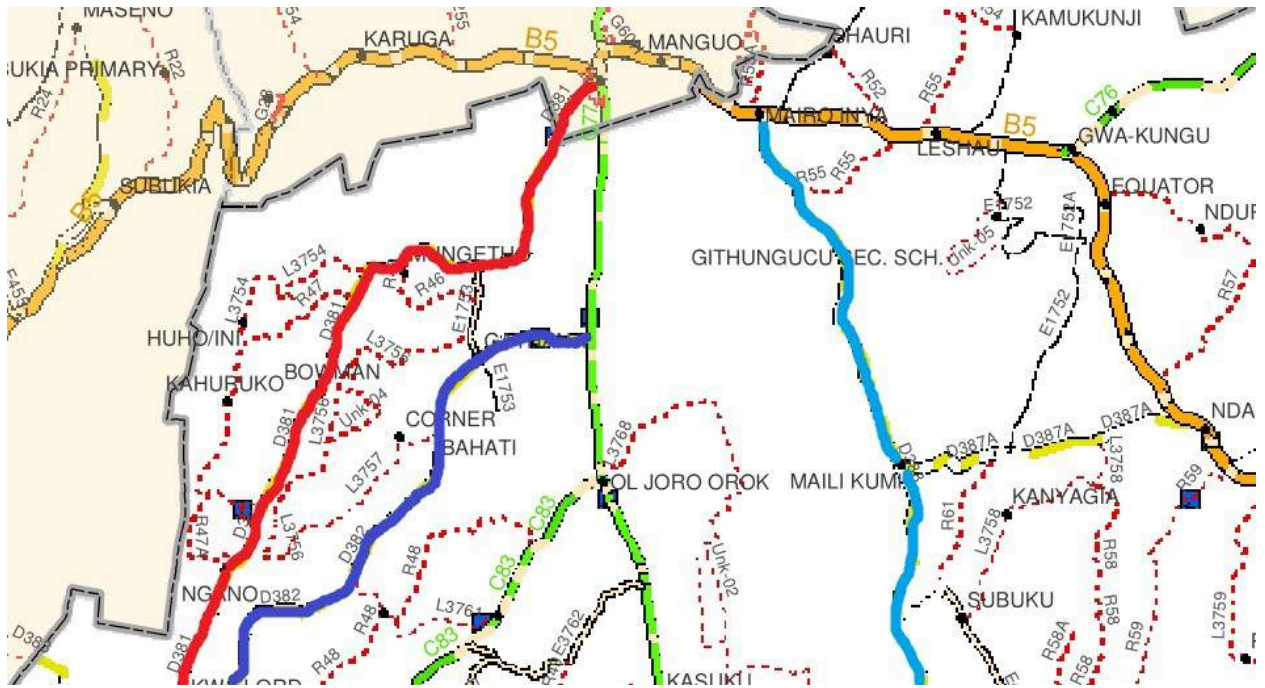

Figure 6: Nyandarua County roads D381, D382 and D388, marked in red, purple and blue respectively

2.0 Mobilization – Preliminary field activities

2.1 Site visit

For the purposes of capacity building, the consultant set out for a reconnaissance tour, together with the Project Manager from MTRD and one AfCAP consultant. This took place from Friday 29th to Saturday 30th April, 2016.



Figure 7: AfCAP consultant (Eng. Otto) and MTRD Project Manager (Eng. Mbarua) guiding Across Africa Overseeing Engineer, Waswa, on the reconnaissance tour of Trial Section D379

From the site visit, the consultant was able to note the following:

2.1.1 Raingauge installation centres

For all the trial sections under study, the consultant was able to identify a nearby school or church or responsible homestead, which would later be approached for negotiation on using their premises to install the raingauges for rainfall data collection. Sections such as D379, E579, D435, D381 and D382 all have schools close to the site, and these are possible raingauge installation centres. Other sections such as E511 have homesteads adjacent to the site which can be approached for maintenance of the raingauges.

The trial sections D419, D420 and D421, due to their close proximity, will have a common raingauge. All the other sections, even though in one region, will each have its own raingauge, to cater for the local variations in rainfall amounts.

2.1.2 Operational logistics

The consultant was able to understand the exact location of the sites and which of the sites can be combined when carrying out the tests so as to increase the operational efficiency. For the three roads in Murang'a, (D419, D420, D421) the sections to be monitored shall be located near Gakoigo junction so that the consultant can supervise works in all the three sites with ease. The three

sections in Nyandarua (D381, D382, D388) shall also be grouped together. Also D435 and E579 in Nyeri, and D379 and D415 in Kiambu county.

The consultant was also able to identify the towns in which the staff will operate from while works on the sites is going on. The consultant shall be lodged at Maragua town while supervising the 3 roads in Murang'a County. For the 3 roads in Nyandarua County, the consultant shall operate from Nyahururu town. Nyeri town will serve as a good base while supervising works on the 2 roads in Nyeri County. For the 3 roads in Kiambu County, Thika town would be a good base to operate from.

The exact travelling distances from site to site were all noted and an estimation of the total distance to be covered by the consultant was made. The consultant is therefore now in a position to wisely plan his movement.

2.1.3 Source of labour

As the Kenyan law stipulates, for such projects, some percentage of labour must come from the locals. The consultant was able to identify villages and towns near each trial section to be monitored, where casual labourers will be easily sourced from. The police posts at Ngano, Wamwangi, Maragua, Nyeri and Nyahururu will provide security guards for the safety of the workers during data collection in the field.

2.1.4 KeRRA regional offices

The consultant was able to identify the location of KeRRA regional offices for the four counties. Some are just adjacent to the site. This will come in handy when it comes to reinstatement of the trial pits and the DCP holes. The consultant is planning to talk with the respective KeRRA regional managers to assist in obtaining premixed asphalt, murrum and aggregate slurry as and when required.

2.1.5 Site safety

The busiest roads, by mere visual inspection, were identified as D419, D420, D381 and D415. These have a relatively high volume of traffic at any particular time. The consultant shall have to put proper site safety measures to curb accidents while work is in progress.

Sections such as E511 and D435 are both on a downhill slope from the main road and the roads have lots of curves. Motorbikes and heavy trucks notoriously speed down these narrow windy roads and can cause harm if not well checked. At some instances, the line of sight around these may not be sufficient to allow overspeeding motorbikes to react soundly on noticing activity on the road. Tight road safety measures will have to be enforced by the consultant on these sections.

For sections D379, D421 and D388 no major traffic management difficulty is envisaged. These roads have generally low volumes of Traffic. Section D382 has big seasonal fluctuations in the traffic, from the normal traffic to peak traffic during the potato harvesting season.



Figure 8: AfCAP consultant, MTRD Project Manager and Across Africa Overseeing Engineer deliberating on the road safety measures required on Trial Section D435

2.1.6 Elements for close attention

Trial section D381 was done by 2 different contractors. The first section has so far experienced extensive surface cracking of the crocodile type. The base, by initial visual inspection, seems to be firm enough, but nevertheless the surface is extensively cracking. This phenomenon has to be properly investigated and concrete reasons established.

The section is also very bumpy and does not offer a smooth drive. The second section is not consistent in terms of the materials used for the wearing surface. The variances can easily be seen by eye observation.

Section E579 is the muddiest of all the roads. This is attributed to the numerous access earth roads, which are basically earth roads of red coffee soils. The sealed pavement has also since construction been encroached by grass and thus the soil cannot be easily washed away. This section will require washing before road marking is done.

2.2 Desk studies

Across Africa has done some preliminary literature review on the trial sections to be monitored. This included determining the exact locations of the 12 roads from the Kenya Roads Board Map, and studying the design and construction of Road D379.

The consultant has requested the MTRD Project Manager to avail the design documents and construction records for all the 12 trial sections before embarking on the baseline survey. These will be reviewed as the project rolls on, to obtain any required information on the pavements.

2.3 Preliminary Site Activities

With the help of one of the AfCAP consultants, Across Africa was able to commence the preliminary field activities.

These include:

- Installation of raingauges

- Road marking
- Visual inspection

2.3.1 Raingauge installation

With the guidance of the AfCAP Consultant, this was successfully done on Friday, 13th May, 2016 for trial section E511. We located a responsible homestead right at the beginning of the site. The home owner agreed to help us collect rainfall data for the area by daily reading and recording the rainfall amounts.

An open space was identified within the owner’s compound. The main criteria for selecting the site was the exposure of the gauge to rain and accessibility of the gauge for the reader while minimizing attraction to vandals.

The raingauge was mounted on a sturdy 5 feet high 100 by 50 mm wooden post, well seated in the ground. This was meant to make it comfortable for the person responsible for taking the readings, as well as getting it out of the reach of small children. The reader was adequately trained, ready for the job. The following is a sample of the readings recorded so far:

Rainfall Registration Chart													Year: 20__
DATE	JAN	FEB	MAR	APRIL	MAY	JUNE	JULY	AUG	SEPT	OCT	NOV	DEC	DATE
	mm	mm	mm	mm	mm	mm	mm	mm	mm	mm	mm	mm	
1						—							1
2						—							2
3						—							3
4													4
5													5
6													6
7													7
8													8
9													9
10													10
11													11
12													12
13													13
14													14
15					2.6								15
16					3.0								16
17					—								17
18					22.6								18
19					40.2								19
20					39.0								20
21					6.2								21
22					2.2								22
23					0.4								23
24					2.0								24
25					0.4								25
26					0.6								26
27					9.4								27
28					0.8								28
29					—								29
30					—								30
31					—								31
Totals													
No of Days													

Figure 9: A sample recording of rainfall amounts from the day of installation of the raingauge to date



Figure 10: Across Africa team with Jon Hongve of AfCAP training a local on how to read and record daily rainfall amounts (Trial Section E511)

2.3.2 Road marking

The consultant has done road marking on all the 11 sites in preparation for the other site works that are to follow. This exercise was conducted from Friday, 13th May, 2016 to Saturday, 28th May, 2016. The AfCAP consultant guided the combined team of Across Africa Consultants and MTRD in marking the first three sites, namely D379, E511 and D388.

2.3.2.1 Road marking templates

For this exercise, the consultant used 3 major road marking templates as illustrated in the figure below:

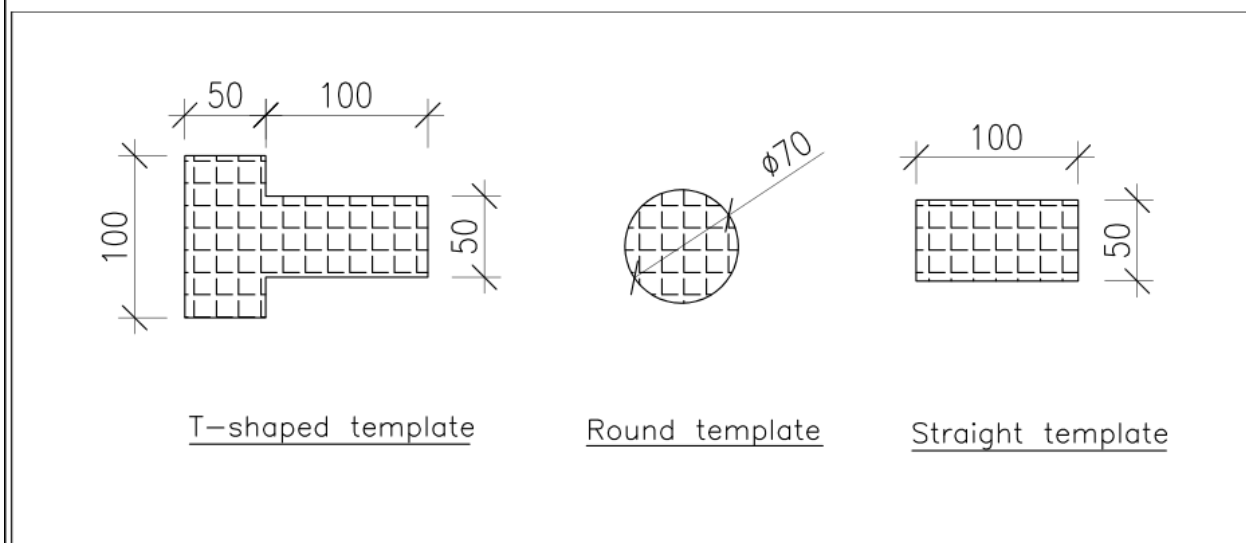

Figure 11: Dimensions of the road marking templates used (adopted from Kenya LTPP guideline)

These are better illustrated in the image below. The workers would lay down the templates flat on the pavement and paint the opening.



Figure 12: Across Africa team using the three road marking templates

2.3.2.2 Paint

The consultant used Crown Road marking paint, made from a chlorinated rubber base. This has a fast drying time. No thinner was used because if included, it reacts with bitumen, dissolving it in such a way that it mixes with the paint, which may lead to pavement deterioration.

Some trial sections, especially E579, required a lot of sweeping of the dust and dirt so as to expose the surface for painting. Other sections were generally clean and could be painted without any need of sweeping

2.3.2.3 Beginning and ending of Section to be monitored

This was marked by a 50 mm wide solid line running across the whole width of the pavement. The chainage of this starting point was marked as km 0 + 000. The chainage of the ending point depends on the length of the section being monitored, but the maximum was km 1 + 000.



Figure 13: The solid line with chainage 0 + 000 marking the beginning of the section to be monitored

2.3.2.4 LTPP section

This measured 200 m long for each trial section. The edges of the destructive zones were demarcated by a dashed line as shown in the image below. The test points falling on this edge were offset 500 mm from the dashed line



Figure 14: The dashed line marking the boundary of the destructive testing panel of the LTPP section



Figure 15: One profile offset 500 mm from the edge of the dashed line

2.3.2.5 Centre line of the road

This was marked using a plus sign as advised by one of the AfCAP consultants. The centre line was accurately obtained by measuring the whole width of the road and locating the middle point. In some instances, like in the case of D415, where the lanes are of different widths, the peak of the camber was taken as the centre line, or rather the yellow line, where it existed.

2.3.2.6 Marking plans

The trial sections to be monitored are either 5.4 m or 6 m wide. Others have wide shoulders whereas others lack. Therefore, the marking plan adopted depended on the width of the pavement. Typical marking plans for a 6 m wide and 5.4 m wide road are shown below:

For some road sections, the outer and inner wheel paths are not clearly defined, and thus it took proper judgement to locate the real wheel paths. This is common in low volume roads, where vehicles tend to drive more or less in the middle of the road.

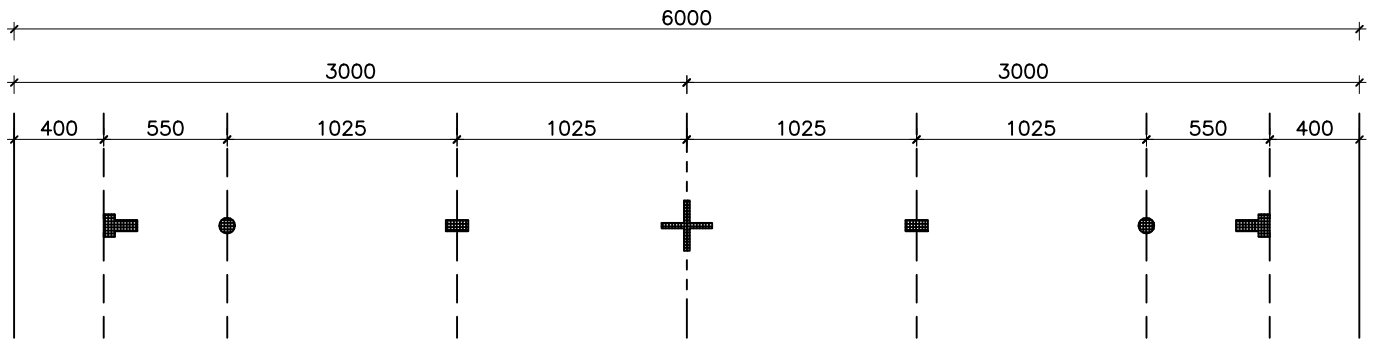

MARKING PLAN FOR 6 M WIDE SEALED SURFACING, OUTER WHEEL PATH
(Adapted from Kenya LSPS Guideline)

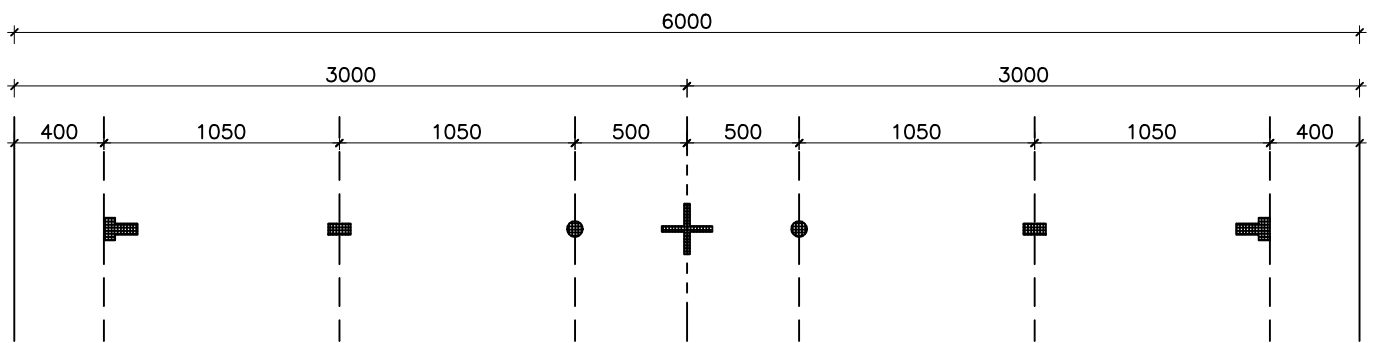

MARKING PLAN FOR 6 M WIDE SEALED SURFACING, INNER WHEEL PATH
(Adapted from Kenya LSPS Guideline)

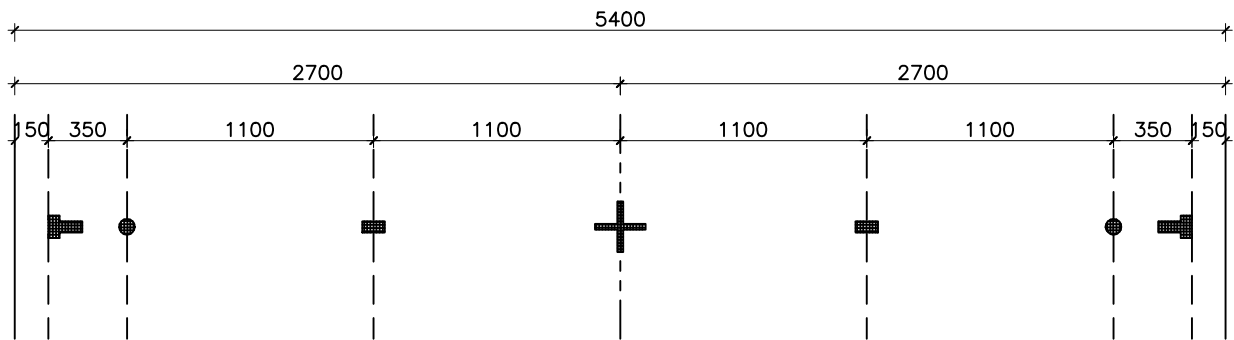

MARKING PLAN FOR 5.4 M WIDE SEALED SURFACING, OUTER WHEEL PATH
(Adapted from Kenya LSPS Guideline)

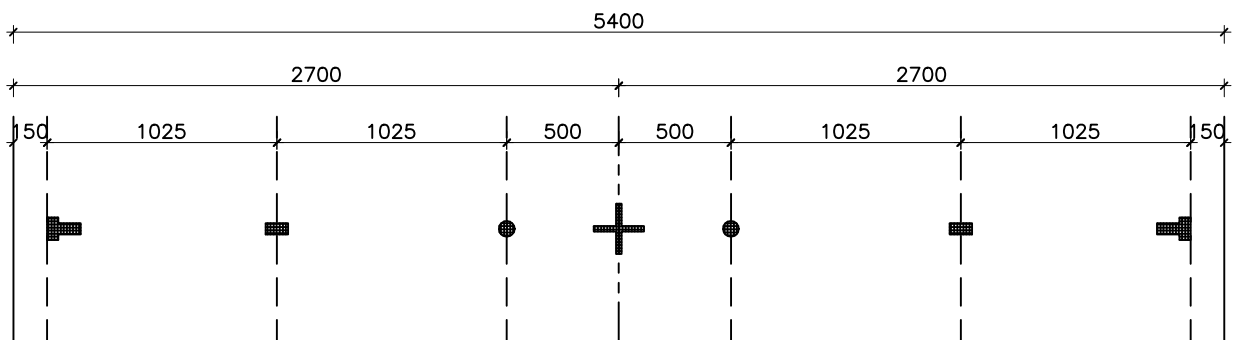

MARKING PLAN FOR 5.4 M WIDE SEALED SURFACING, INNER WHEEL PATH
(Adapted from Kenya LSPS Guideline)

2.3.2.7 Labelling

This included:

- Writing the chainages of all the profiles
- Numbering the 10 LTPP 15 m sections
- Marking the destructive testing zones as either panel A or B



Figure 16: Typical chainage of a profile



Figure 17: Typical numbering of the LTPP sections

2.3.3 Visual inspection

This was conducted for a small section of Road D388 with the guidance of the AfCAP consultant and the corresponding form duly filled. This involved observation and recording:

- Extent of Ravelling/Stone loss
- Pothole formation/Delamination
- Degree of Edgebreaks
- Type and extent of cracking
- Existence of Depressions/Subsidence on the road pavement
- Drainage condition and type along the road pavement

3.0 Proposed Plan

3.1 Maintenance to D435

During the preliminary fieldwork activities, the AfCAP Consultant and Across Africa Consultants identified sections on Road D435 totaling 1472 m² that needed slurry or sand sealing and advised the Nyeri KeRRA Regional Manager accordingly.

3.2 The Way Forward

The trial sections having all been visited and properly marked, the consultant is planning to embark on the actual field work. This will involve:

- Completing the installation of raingauges for all the remaining sites
- Carrying out detailed visual inspection for the remaining sites
- Installation of concrete pillars for section identification
- Conducting 7 days manual traffic counts and 4 days axle load surveys
- Sampling of materials from trial pits and subsequent testing of the same
- Rut depth measurement
- Roughness measurement
- In-situ strength measurement by the Dynamic Cone Penetrometer

Across Africa was able to sit down with MTRD and come up with a detailed time schedule for the tests to be carried out, as seen in the chart overleaf. Mobilization of the various teams and equipment is planned for Monday, 13th June, 2016, and the actual field activities will begin on Tuesday, 14th June, 2016.

MTRD will use the following equipment:

S/N	Parameter	Equipment
1	Rut depth	Straight edge
2	Roughness	Roughometer
3	Stiffness/Deflection	Falling Weight Deflectometer
4.	Axle Load	Portable weighing pads
5	Pavement strength	Dynamic Cone Penetrometer

The key personnel in this project remain as follows:

- Project Manager – Eng. Joachim Mbarua
- Overseeing Engineer – Eng. Ambrose Waswa
- Technician Supervisor – Stephen Nyakeya

Activity Work Schedule (Monitoring and Evaluation of Low Volume Roads Trial Sections in Kenya)

1st PERFORMANCE MONITORING ROUND, Nov 2016

S/N	Road Sections/Activity	1st PERFORMANCE MONITORING ROUND, Nov 2016																																																							
		1st month														2nd month																																									
		1st week				2nd week				3rd week				4th week				5th week				6th week				7th week				8th week																											
1	2	3	4	5	6	7	8	9	10	11	12	13	14	15	16	17	18	19	20	21	22	23	24	25	26	27	28	29	30	31	32	33	34	35	36	37	38	39	40	41	42	43	44	45	46	47	48	49	50	51	52	53	54	55	56		
1	0275 Nairobi																																																								
	Road Marking, VCS, Drainage Ass.																																																								
	DCP tests																																																								
	Base Layer Moisture Content																																																								
	Trial Pits																																																								
	FWD Tests																																																								
	Rut Depth																																																								
	Traffic Counts																																																								
2	ES11 Murang'a																																																								
	Road Marking, VCS, Drainage Ass.																																																								
	DCP tests																																																								
	Base Layer Moisture Content																																																								
	Trial Pits																																																								
	FWD Tests																																																								
	Rut Depth																																																								
	Traffic Counts																																																								
3	0435 Wajir																																																								
	Road Marking, VCS, Drainage Ass.																																																								
	DCP tests																																																								
	Base Layer Moisture Content																																																								
	Trial Pits																																																								
	FWD Tests																																																								
	Rut Depth																																																								
	Traffic Counts																																																								
4	0527 Kericho																																																								
	Road Marking, VCS, Drainage Ass.																																																								
	DCP tests																																																								
	Base Layer Moisture Content																																																								
	Trial Pits																																																								
	FWD Tests																																																								
	Rut Depth																																																								
	Traffic Counts																																																								
	Data Entry																																																								
	Laboratory testing																																																								
	Analysis																																																								
	Draft Report																																																								
	Final Report																																																								

Activity Work Schedule (Monitoring and Evaluation of Low Volume Roads Trial Sections in Kenya)
4th PERFORMANCE MONITORING Round, June 2018

S/N	Road Sections	1st month																												2nd month											
		1st week						2nd week						3rd week						4th week						5th week						6th week									
		1	2	3	4	5	6	7	8	9	10	11	12	13	14	15	16	17	18	19	20	21	22	23	24	25	26	27	28	29	30	1	2	3	4	5	6	7	8	9	10
1	D379 Kiambu																																								
	Rd marking, VCS, drainage ass	█																																							
	Roughness measurement	█																																							
	DCP tests					█																																			
	Rut depth measurement	█																																							
	Traffic Count	█																																							
2	E511 Murang'a																																								
	Rd marking, VCS, drainage ass	█																																							
	Roughness measurement					█																																			
	DCP tests							█																																	
	Rut depth measurement						█																																		
	Traffic Count	█																																							
3	D435 Nyeri																																								
	Rd marking, VCS, drainage ass											█																													
	Roughness measurement								█																																
	DCP tests										█																														
	Rut depth measurement									█																															
	Traffic Count	█																																							
4	D382 Nyandarua																																								
	Rd marking, VCS, drainage ass											█																													
	Roughness measurement											█																													
	DCP tests												█																												
	Rut depth measurement												█																												
	Traffic Count	█																																							
	Data Entry	█																																							
	Analysis										█																														
	Draft Report																							█																	
	Final Report																																								