

REPUBLIC OF MALAWI



Ministry of Transport and Public Works



# **DESIGN MANUAL**

## **for Low Volume Sealed Roads Using the DCP Design Method**

---

September 2013



REPUBLIC OF MALAWI



Ministry of Transport and Public Works

**DESIGN MANUAL**  
**for Low Volume Sealed Roads**  
**Using the DCP Design Method**

---

September 2013

## FOREWORD

I am pleased to provide the foreword to this *Design Manual for Low Volume Sealed Roads Using the DCP Design Method*. Since the publication of the Ministry's Highway Design Manual in 1978, ongoing research in the southern African region, including Malawi, has led to new technologies and practices in the cost-effective provision of low volume sealed roads. As a result, the current manual is no longer appropriate for the design of low volume sealed roads, and a new manual is required to reflect these developments. This Manual supports the Malawi Government's policy of providing safe and reliable all-season road access to the country's rural population through the use of appropriate and cost-effective interventions.

The Government of Malawi commits significant funding for the improvement of road infrastructure in the country. It is therefore important that such funding is utilised efficiently and effectively by all roads agencies in Malawi. This can be achieved by their adherence to the best practice methods and techniques included in the Manual. This Manual will complement the Ministry's efforts in providing policy guidance to the construction industry in the upgrading of gravel and earth roads to a paved standard.

I am pleased to note that the preparation of the Manual was undertaken in close consultation with all stakeholders in the road sector to ensure that it best meets practitioners' requirements.

It is my sincere hope that this Manual will herald a new era in the more efficient and effective provision of low volume sealed roads in Malawi. In so doing, it will make a substantial contribution to the improved infrastructure of our country and, in the process, enhance economic growth and reduce poverty.

I commend this manual to all stakeholders in the road sector.

Hon. Mohammed Sidik Mia  
Minister of Transport and Public Works

## PREFACE

The Ministry of Transport and Public Works is charged with the responsibility of providing adequate, safe and well maintained transport infrastructure to effectively contribute to the socio-economic growth and development of the country.

In discharging its responsibilities, the Ministry uses the Roads Authority to execute its policy in the road sector. In this regard, the Authority is mandated to develop and maintain the classified road network to an appropriate standard.

One of the major challenges faced by the Roads Authority has been the management of a large network of unpaved roads which have imposed a significant technical and financial burden on the organization. This is due, in part, to the use of non-renewable gravel resources which are being seriously depleted. For these reasons, the Authority initiated the development of a new *Design Manual for Low Volume Sealed Roads Using the DCP Design Method*. The design approaches included in the Manual are based on the body of local research information that has been available from previous research and investigations carried out both in Malawi and in the region.

The Manual serves as a standard reference and source of good practice for the design and construction of low volume sealed roads. The aim of the Manual is to provide all practitioners with comprehensive guidance on the wide range of factors that need to be addressed in a holistic manner when undertaking the upgrading of unpaved roads to a paved standard.

The Ministry expects all practitioners in the road sector to adhere to the approaches set out in the Manual. This will ensure that a consistent, harmonised approach is followed in the design and construction of low volume sealed roads in the country.

The Manual, by its very nature, will require periodic updating to take account of the dynamic nature of developments in low volume road technology. The Ministry, therefore, would welcome comments and suggestions from any stakeholders as feedback on all aspects of the Manual during its implementation. All feedback will be carefully reviewed by professional experts with a view to amending future updates of the manual.

Moffat Chitimbe  
Secretary for Transport and Public Works

## ACKNOWLEDGEMENTS

The Ministry of Transport and Public Works wishes to acknowledge the valuable support that was provided by the United Kingdom Department for International Development (DFID) for the preparation of the *Design Manual for Low Volume Sealed Roads Using the DCP Design method*. The project was carried out under the aegis of the Africa Community Access Programme (AFCAP) – a DFID-funded research programme that promotes safe and sustainable access for rural communities in Africa. The project was managed by the Malawi Roads Authority, under the direction of its Chief Executive officer - Eng. P.J. Kulemeka.

The project benefitted from the valuable inputs provided by a Technical Working Group comprising professionals from both public and private sector organisations. The Technical Working Group participated in workshop discussions, field work and training during the process of the development of the Manual. The Technical Working Group comprised the following persons:

### Technical Working Group

---

#### Ministry of Transport and Public Works:

- Mr. K. Mphonda
- Mr. T. Masimbi

#### Ministry of Local Government and Rural Development:

- Mr. H. Kumwenda
- 

#### Roads Authority

- Eng. P.C. Kasakatira
- Eng. B.C. Kapoteza
- Eng. F. Dimu

- Eng. D. Kalinde
  - Mr. W. Kaunde
  - Mr. S. Banda
- 

#### Road Fund Administration

- Mr. G. Gondwe

#### University of Malawi

- Dr. I. Ngoma
- 

#### National Construction Industry Council

- Mr. G. Khonje

#### Consultants

- Eng. T. Hiwa
  - Eng. D. Kara
- 

#### Contractors

- Mr. F. Kavwenje
- Mr. R. Dilawo

#### Facilitator

- Eng. J. Chagunda
-

**Project Management:**

The project was managed by the Crown Agents and carried out under the general guidance of the AFCAP Technical Services Manager, Eng. R. Geddes.

**Manual Development**

The manual was developed and written by Eng. M. Pinard, AFCAP consultant.

**Peer Review**

The manual was reviewed by the following researchers who have all been involved in various aspects of DCP development and its application to LVSR design:

- Dr. J. Rolt, Independent Consultant, formerly Chief Research Scientist, UK Transport Research Laboratory
- Dr. P. Paige-Green, Chief Researcher, CSIR, South Africa
- Eng. E. Kleyn, Independent Consultant, South Africa
- Eng. G. van Zyl, Independent Consultant, South Africa

## LIST OF ABBREVIATIONS

>	Greater than
<	Less than
%	Percentage
<hr/>	
<b>A</b>	<p>AA DT Average Annual Daily Traffic</p> <p>AFCAP Africa Community Access Programme</p> <p>ASTM American Society for Testing Materials</p>
<hr/>	
<b>B</b>	BS British Standard
<hr/>	
<b>C</b>	<p>CBR California Bearing Ratio</p> <p>CESA Cumulative Equivalent Standard Axles</p> <p>CML Central Materials Laboratory</p> <p>CSIR Council for Scientific and Industrial Research</p> <p>CUSUM Cumulative Sum</p>
<hr/>	
<b>D</b>	<p>DBM Drybound Macadam</p> <p>DCP Dynamic Cone Penetrometer</p> <p>DESA Design Equivalent Standard Axles</p> <p>DF Drainage Factor</p> <p>DN The average penetration rate in mm/blow of the DCP in a pavement layer</p> <p>DSN<sub>800</sub> The total number of blows required to penetrate the pavement to a total depth of 800mm (Pavement Structure Number)</p>
<hr/>	
<b>E</b>	<p>EF Equivalence Factor</p> <p>ESA Equivalent Standard Axle (80 kN)</p> <p>EMC Equilibrium Moisture Content</p> <p>EOD Environmentally Optimised Design</p>
<hr/>	
<b>G</b>	GPS Global Positioning System
<hr/>	
<b>H</b>	<p>HGV Heavy Goods Vehicle</p> <p>HV Heavy Vehicle</p> <p>HVR High Volume Road</p>
<hr/>	
<b>I</b>	<p>IDD In Situ Dry Density</p> <p>ILO International Labour Organisation</p> <p>IWP Inner Wheel Path</p>
<hr/>	
<b>K</b>	kN Kilo Newton
<hr/>	
<b>L</b>	<p>LGV Light Goods Vehicle</p> <p>LHS Left Hand Side</p> <p>LL Liquid Limit</p> <p>LSD Layer Strength Diagram</p> <p>LSP Layer Strength Profile</p> <p>LV Low Volume</p>

	LVR	Low Volume Road
	LVSR	Low Volume Sealed Road
<b>M</b>	MC	Moisture Content
	MDD	Maximum Dry Density
	MGV	Medium Goods Vehicle
	MK	Malawi Kwacha
	MESA	Million Equivalent Standard Axles
<b>N</b>	NCIC	National Construction Industry Council
	NG	Natural Gravel
	NMT	Non-motorised Traffic
	NPV	Net Present Value
<b>O</b>	OMC	Optimum Moisture Content
	ORN	Overseas Road Note
	OWP	Outer Wheel Path
<b>P</b>	P075	Percentage material passing the 0.075mm sieve
	PI	Plasticity Index
	PL	Plastic Limit
	PM	Plastic Modulus
<b>R</b>	RA	Roads Authority
	RC	Relative Compaction
	RHS	Right Hand Side
<b>S</b>	SADC	Southern African Development Community
	SB	Subbase
	SG	Subgrade
<b>T</b>	ToR	Terms of Reference
	TRL	Transport Research Laboratory
<b>U</b>	UCS	Unconfined Compressive Strength
	UK	United Kingdom
	USD	United States Dollar
<b>V</b>	VEF	Vehicle Equivalence Factor
	VOC	Vehicle Operating Costs
	vpd	Vehicles Per Day
<b>W</b>	WBM	Waterbound Macadam
	WIM	Weigh-in-Motion

## CONTENTS

Foreword	II
Preface	III
Acknowledgements	IV
List of Abbreviations	VI

### PART A: OVERVIEW

#### 1. INTRODUCTION

1.1 Background	1
1.2 Purpose	1
1.3 Scope	1
1.4 Development	2
1.5 Structure and Contents	3
1.6 Benefits of Using the Manual	3
1.7 Sources of Information	4
1.8 Updating the Manual	4

#### 2. MAIN COMPONENTS OF A LVSR

2.1 Pavement	5
2.2 Cross Section	6
2.3 Drainage Elements	6

### PART B: ROAD DESIGN PROCESS

#### 1. DESIGN PROCESS

1.1 Introduction	9
1.2 Purpose and Scope	9
1.3 Goal	9

#### 2. PRELIMINARY ROAD EVALUATION

2.1 Introduction	11
2.2 Purpose and Scope	11
2.3 General Assessment	11
2.4 Visual Assessment	12
2.5 Structural Assessment	14
2.5 Strip Maps	16

#### 3. TRAFFIC

3.1 Introduction	25
3.2 Purpose and Scope	25
3.3 Procedure for Estimating Design Traffic	26

#### 4. GEOMETRICS AND ROAD SAFETY

4.1 Introduction	35
4.2 Purpose and Scope	35
4.3 Geometrics	35
4.4 Road Safety	38

<b>5. PAVEMENT DESIGN</b>	
5.1 Introduction	47
5.2 Purpose and Scope	47
5.3 Background to DCP Method	47
5.4 Design Principles	47
5.5 DCP Design Procedure	51
5.6 Strengths and Limitations of the DCP Design Method	54
<b>6. MATERIALS</b>	
6.1 Introduction	61
6.2 Purpose and Scope	61
6.3 Approach to Using Local Materials	61
6.4 Selection of Materials	62
6.5 Specification of Materials	64
6.6 Testing of Materials	64
<b>7. SURFACINGS</b>	
7.1 Introduction	69
7.2 Purpose and Scope	69
7.3 Bituminous Surfacing	69
7.4 Non-Bituminous Surfacing	72
7.5 Factors Affecting Choice of Surfacing	75
7.6 Life Cycle Cost Analysis	76
<b>8. DRAINAGE</b>	
8.1 Introduction	81
8.2 Purpose and Scope	81
8.3 Hydrology	81
8.4 Road Level	82
8.5 Road Surface Drainage	83
8.6 Subsurface Drainage	84
8.7 Drainage Channels	84
8.8 Culverts	89
8.9 Low Level Structures	90
8.10 High Level Bridges	91

## **PART C: DESIGN PHILOSOPHY AND GUIDELINES**

<b>1. DESIGN CONSIDERATIONS</b>	
1.1 Introduction	93
1.2 Design Approach	93
1.3 The Road Environment	94
1.4 Environmentally Optimised Design	95
1.5 Design Strategy	95
1.6 Surfacing Options	96
1.7 Context Sensitivity	97

<b>2. ENVIRONMENT</b>	
2.1 Introduction	101
2.2 Climate	101
2.3 Moisture Regime	104
<b>3. MATERIALS</b>	
3.1 Introduction	107
3.2 Materials Characteristics	107
3.3 Local Materials	110
3.4 Specifications	110
3.5 Materials Selection	111
3.6 Materials Testing	113
3.7 Materials Prospecting	113
<b>4. PAVEMENT DESIGN</b>	
4.1 Introduction	117
4.2 Pavement Design Methods	118
<b>5. PRACTICAL CONSIDERATIONS</b>	
5.1 Introduction	123
5.2 Problem Soils	123
5.3 Construction Issues	126
5.4 Vehicle Overloading	129
5.5 Maintenance Issues	129
5.6 Road Safety	131
<b>6. COST ANALYSIS</b>	
6.1 Introduction	133
6.2 Life-Cycle Cost Analysis	133
6.3 Optimum Pavement Design Solution	136
<b>7. IMPLEMENTATION</b>	
7.1 Introduction	139
7.2 Planning Impacts	139
7.3 Design Impacts	140
7.4 Construction Impacts	140
7.5 Maintenance Impacts	141
7.6 Pavement Monitoring Impacts	141
7.7 Environmental Impacts	141

## ANNEXES

Annex 2B:	Example of Determination of Uniform Sections from CUSUM Analysis	20
Annex 2C:	Determination and Choice of DN Percentile Values	21
Annex 2D:	Sample of Strip Map	22
Annex 2E:	Evaluation of Condition of Existing Gravel Road	23
Annex 3A:	Determination of Normal, Generated and Diverted Traffic	32
Annex 3B:	Design Example: Determination of Traffic Design Loading	33
Annex 4A:	Speed Reduction Measures in Villages	39
Annex 5A:	Determination of Strength-Balance of Pavements	56
Annex 6A:	Determination of Laboratory DN Value	65
Annex 7A:	Life Cycle Cost Comparison between a Single Otta Seal plus Sand Seal and a Double Chip Seal (hypothetical only)	78
Annex: A:	DCP Design Example	145
Annex A1:	Alpha-Beta Road: DCP Results and Analysis	151
Annex A2:	Determination of 80 <sup>th</sup> Percentile Values for Uniform Sections	154
Annex A3:	Uniform Sections	156
Annex A4:	Layer Strength Diagrams	156
Annex B:	Glossary of Terms	160

## LIST OF FIGURES

### PART A

Figure 1-1:	Structure of the Manual	3
Figure 2-1:	Main components of a LVSR pavement	5
Figure 2-2:	Cross Section	6
Figure 2-3:	Drainage elements	6

### PART B

Figure 1-1:	Road design process	10
Figure 2-1:	Typical DCP effects with large stone in pavement layer	19
Figure 3-1:	Procedure for establishing design traffic class	25
Figure 3-2:	Structural design period	26
Figure 3-3:	Relationship between BN100 and Load Equivalent Exponent (n) for strength-balanced pavements	29
Figure 4-1:	Road cross section	35
Figure 4-2:	Details of road edge	37
Figure 5-1:	The DCP	48
Figure 5-2:	Layer-strength profile	49
Figure 5-3:	Relationship between DN and CBR	50
Figure 5-4:	Flow diagram of DCP design procedure	51
Figure 5-5:	Collective DCP design profiles	52
Figure 5-6:	Average and extreme DCP strength profiles	52
Figure 5-7:	Layer-strength diagram for various traffic classes	53
Figure 5-8:	Comparison of required and in situ strength profiles	53
Figure 6-1:	DN/density/moisture relationship	53
Figure 7-1:	Common types of bituminous surfacings	70
Figure 7-2:	Cost components of a LCC analysis between a single Otta seal+sand seal and Double Surface Dressing	77
Figure 8-1:	Crown height for LVSRs	82
Figure 8-2:	Potential drainage problems associated with depressed pavement construction	83
Figure 8-3:	Beneficial interception of surface runoff and subsurface seepage	84
Figure 8-4:	Types of side drain	85
Figure 8-5:	Typical masonry scour check	86
Figure 8-6:	Typical layout of mitre drain	87
Figure 8-7:	Mitre drain angle greater than 45 degrees	88
Figure 8-8:	Interceptor, cut-off or catchwater drain	89

## PART C

Figure 1-1:	Traffic loading versus dominant mechanism of pavement distress (Schematic only)	94
Figure 1-2:	Road environment factors	94
Figure 1-3:	Application of the principle of environmentally optimised design	95
Figure 1-4:	Framework for sustainable provision of LVSRs	97
Figure 2-1:	Distribution of rainfall in Malawi	102
Figure 2-2:	Moisture movements in pavements and subgrades	104
Figure 3-1:	Flow diagram stages for materials prospecting	114
Figure 4-1:	Wheel load transfer through pavement structure	117
Figure 5-1:	Moisture movements in expansive soils under a paved road	124
Figure 5-2:	Determination of soil expansiveness (Modified Van de Merwe Chart)	124
Figure 5-3:	Illustration of concept of “compaction to refusal”	127
Figure 5-4:	Deflection-life relationship showing benefits of “compaction to refusal”	127
Figure 5-5:	Impact of overloading on pavement performance	129
Figure 6-1:	Alternative pavement options	133
Figure 6-2:	Distribution of costs and benefits during the life cycle of a road option	134
Figure 6-3:	Components of a typical life cycle cost analysis	135
Figure 6-4:	Combined cost for various pavement structure capabilities	136
Figure 7-1:	Road project cycle and influence on final cost	139

---

## LIST OF TABLES

### PART A

Table 2-1:	Purpose of main pavement components	5
------------	-------------------------------------	---

### PART B

Table 1-1:	Road design process	10
Table 2-1:	Frequency of DCP testing:	14
Table 2-2:	Percentiles of maximum DCP penetration rate to be used to assess in situ material condition	15
Table 3-1:	Structural design period	27
Table 3-2:	Vehicle classification for traffic counts	28
Table 3-3:	Commercial vehicle classification	28
Table 3-4:	Lane width adjustment factor for design traffic	30
Table 3-5:	Designated traffic class for pavement design	31
Table 4-1:	Typically recommended roadway widths	36
Table 4-2:	Safety of slopes (vertical:horizontal)	37
Table 5-1:	DCP design catalogue for different traffic classes	52
Table 6-1:	Approximate relationship between laboratory CBR and DN values at varying moisture contents	62
Table 7-1:	Typical service life of surfacings	71
Table 7-2:	Suitability of various surfacings for use on LVSRs	76
Table 8-1:	Recommended crown height in relation to drain type and longitudinal gradient	82
Table 8-2:	Recommended camber and cross fall for LVSRs	83
Table 8-3:	Spacing between scour checks	87
Table 8-4:	Maximum spacing of mitre drains	89

### PART C

Table 2-1:	Climatic zones: Approximate mean annual rainfall, N-Values and Thornthwaite Moisture Index	103
Table 3-1:	Pavement material types and characteristics	108
Table 3-2:	Variation of CBR with moisture content	109
Table 3-3:	Fundamental pavement material selection factors	112
Table 4-2:	Main characteristics of the DCP design method	120
Table 5-1:	Minimum compaction requirements	128
Table 5-2:	Maintenance activities	130

## LIST OF PHOTOS

### PART B

Photo 7-1:	Example of Cobble Stone surfacing	72
Photo 7-2:	Example of burnt Clay Brick surfacing	73
Photo 7-3:	Example of Concrete Brick surfacing	74
Photo 7-5:	Example of Concrete surfacing (shelter pattern)	74

---

Part: **A**  
**Overview**

# 1. INTRODUCTION

## 1.1 Background

Low volume roads (LVRs), defined as those roads that carry both less than about 300 vehicles per day (vpd) and about 1 million equivalent standard axles over their design life, constitute a significant proportion of the Malawi classified road network. Whilst the approach to the design of these relatively lightly trafficked roads follows the general principles of any good road design practice, they nonetheless differ in a number of respects from the traditional approaches that are generally directed at relatively heavily trafficked roads carrying a greater proportion of multi-axled commercial vehicles. In particular, for LVRs relatively more pavement distress is attributable to the environmental effects than is the case for higher volume situations.

Whilst there are significant life cycle benefits to be achieved from upgrading Malawi's relatively lightly trafficked unpaved roads to a paved standard, the cost of doing so following traditional standards and specifications is prohibitive. However, based on research and investigations carried out over many decades in the Southern African region, including Malawi, there is now performance based evidence on which new design standards and specifications for various aspects of low volume sealed road provision can be based. These findings have been incorporated in the development of this *Design Manual for Low Volume Sealed Roads Using the DCP Design Method* in which the design of the pavement is based specifically on the Dynamic Cone Penetrometer (DCP) design method. The manual reflects historical experience in Malawi and the region and takes full account of the positive experience gained in the country from the construction of similar roads dating back over 20 years.

## 1.2 Purpose

The main purpose of this Manual is to provide practitioners with a rational, appropriate and affordable approach to the design of LVSRs in Malawi. This is achieved by consolidating in one document the latest approaches to the provision of LVSRs including developments in pavement design and surfacing technology and use of road building techniques that allow maximum use to be made of local materials.

The manual is expected to serve as a nationally recognised document, the application of which will harmonise approaches to the provision of LVSRs in Malawi.

## 1.3 Scope

*The Manual applies primarily to the upgrading of existing unsealed LVRs to a sealed standard using the existing alignment to the maximum extent possible.* However, the method can also be used for the design of new roads albeit with a slightly different approach to the evaluation of the in situ conditions and to the construction techniques required. The design is based on the Dynamic Cone Penetrometer (DCP) and is aimed at achieving a balanced pavement design whilst optimising the in situ material strength in the existing gravel road.

Other complementary aspects of road design are also dealt with so as to ensure that they are all addressed in an appropriate manner by the designer. However, the following qualifications to the scope of the manual should be noted:

- **Geometric design:** Since by their very nature LVSRs will generally follow the existing alignment which may not be fully engineered, the *Manual* does not deal with geometric design calculations for determining the horizontal and vertical curvature of the road but, rather, assesses the adequacy of the existing alignment in terms of such issues as safety and drainage.
- **Surfacing design:** A wide range of alternative surfacing types is presented and guidance is provided on the factors which influence their choice for particular applications. However, the detailed design of such surfacings is not addressed as this is available in other guidelines on this subject.
- **Drainage design:** The *Manual* provides a framework to assist the designer in evaluating the adequacy of existing drainage infrastructure and the need for new infrastructure. However, the manual does not deal with detailed drainage design which can be found in other guidelines on this subject.

## 1.4 Development

The development of the manual was overseen by a Technical Working Group comprising a wide cross section of stakeholders in Malawi including representatives from the following organisations:

- Ministry of Transport
- Roads Authority
- Road Fund Administration
- National Construction Industry Council (NCIC)
- University of Malawi
- Consultants
- Contractors
- Road Materials Suppliers

As a result of the high level of local participation in the development of the manual, it has been possible to capture and incorporate a significant amount of local knowledge in the document.

The manual draws extensively on the outputs of previous research and investigation work carried out in Malawi as follows:

- 1) *Performance Review of Design Standards and Technical Specifications for Low Volume Sealed Roads in Malawi*. AFCAP Project MAL/016, May 2011.
- 2) *Collaborative Research Programme on Highway Engineering materials in the SADC Region: Volume 1 – Performance of Low Volume Sealed Roads: Results and Recommendations from Studies in Southern Africa*. UK Transport Research Laboratory, November, 1999.
- 3) *Malawi Low Volume Roads Study: An investigation into the use of Laterite instead of crushed stone or stabilised material as a base course for bituminous surfaced roads*. Scott Wilson Kirkpatrick and Partners/Henry Grace and Partners and Imperial College of Science and Technology, UK. December, 1988.

## 1.5 Structure and Contents

The *Manual* is divided into three sections as follows:

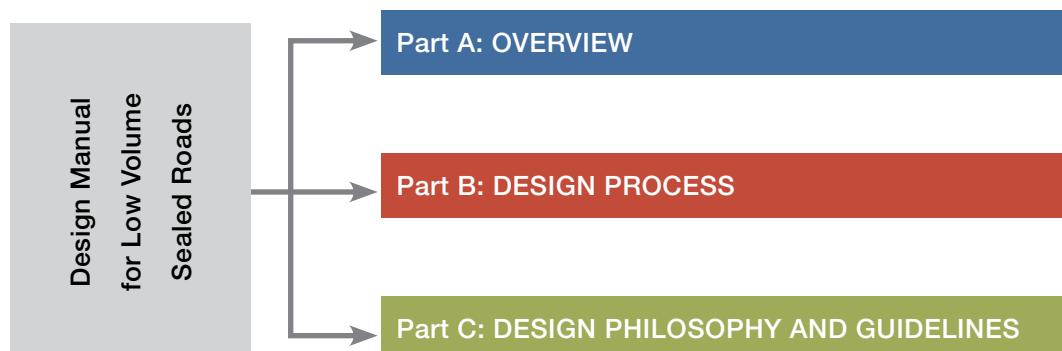

Figure 1-1: Structure of the Manual

- Part A** (this part): Provides an overview of the manual, including its purpose and scope, the approach to its development, its structure and content as well as the benefits to be derived from using the manual and the manner of its updating.
- Part B** Provides the various steps to be followed in the design of a low volume sealed road, including an evaluation of the existing road, the traffic characteristics; the DCP pavement design procedure, an overview of alternative types of surfacings as well as the other related aspects such as drainage, road safety considerations and materials requirements.
- Part C** Provides the design philosophy underlying the relatively new approaches to the design of LVSRs. In so doing, it provides guidance on each aspect of the road design process plus other supplementary topics not addressed in Part B such as the significance of the road environment factors on design, vehicle overloading and practical considerations, such as dealing with problem soils.

## 1.6 Benefits of Using the Manual

There are a number of benefits to be derived from adopting the approaches advocated in the manual. These include providing LVSRs that:

- Are less expensive in economic terms to build and to maintain through the adoption of more appropriate, locally derived technology and design/construction techniques that are better suited to local conditions
- Minimise adverse environmental impacts, particularly with regard to the use of non-renewable resources (gravel)
- Increase employment opportunities through the use of more appropriate technology, including the use of labour based methods where feasible
- Incorporate road safety measures to minimise road accidents

- Take better account of the needs of all stakeholders, particularly the local communities served by these roads
- Foster local road building and maintenance capacity through the greater use of small scale, local contractors
- Ultimately, facilitate the longer term goal of socio-economic growth, development and poverty alleviation in the region

## 1.7 Sources of Information

In addition to providing general information and guidance, the manual also serves as a valuable source document because of its comprehensive lists of references from which readers can obtain more detailed information to meet their particular needs. A bibliography can be found at the end of each chapter of the *Manual*.

## 1.8 Updating of the Manual

As LVSR technology is continually being researched and improved, it will be necessary to update the manual periodically to reflect improvements in practice. All suggestions to improve the manual should be in accordance with the following procedures:

- Any proposed amendments should be sent to the Chief Executive Officer, Roads Authority, motivating the need for the change and indicating the proposed amendment
- Any agreed changes to the manual will be approved by the RA after which all stakeholders will be advised accordingly

## 2. MAIN COMPONENTS OF A LVSR

### 2.1 Pavement

The main components of LVSR pavement are shown in Figure 2-1 and whilst the purpose of these various components is summarised in Table 2-1.

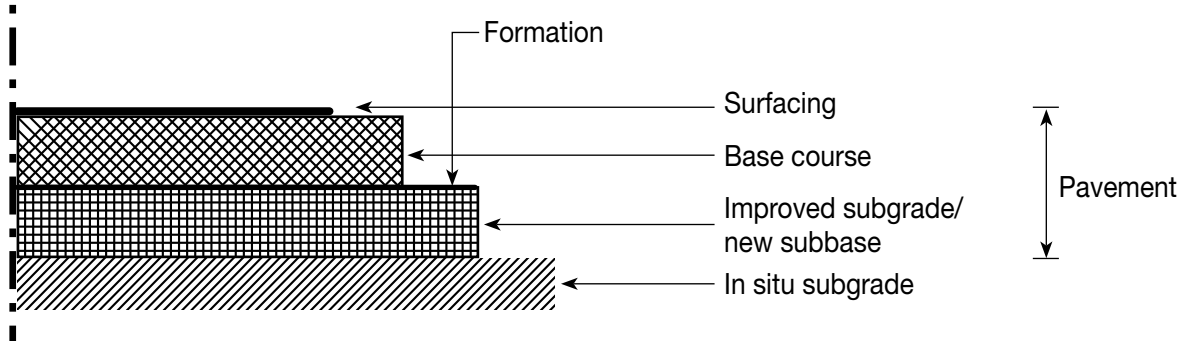

Figure 2-1: Main components of a LVSR pavement

Table 2-1: Purpose of main pavement components

Pavement component	Purpose
Surfacing	<ul style="list-style-type: none"> <li>• Provides a smooth running surface</li> <li>• Provides a safe, economical and durable all-weather surface</li> <li>• Minimises vehicle operating and maintenance costs</li> <li>• Reduces moisture infiltration into the pavement</li> <li>• Provides suitable properties for the local environment, e.g. dust suppression, skid resistance and surface texture</li> <li>• Delineates traffic lanes and shoulders, bicycle paths, traffic calming devices</li> <li>• Visually enhances the road environment for road users and adjacent residents</li> </ul>
Base (base course)	<ul style="list-style-type: none"> <li>• Provides the bulk of the structural capacity in terms of load-spreading ability by means of shear strength and cohesion</li> <li>• Minimises changes in strength with time by having relatively low moisture susceptibility</li> <li>• Minimises the ingress of moisture into the pavement by having adequate shrinkage and fatigue properties</li> <li>• Assists with the provision of a smooth riding surface by having volume stability with time and under load</li> </ul>
Subbase/improved subgrade (reformed & compacted original gravel wearing course)	<ul style="list-style-type: none"> <li>• Provides a stable platform for the construction of the base and surfacing</li> <li>• Assists in providing adequate pavement thickness so that the strains in the in situ subgrade are kept within acceptable limits</li> </ul>
In situ subgrade	<ul style="list-style-type: none"> <li>• Refers to the naturally occurring material on which the pavement and improved subgrade are constructed</li> </ul>

## 2.2 Cross Section

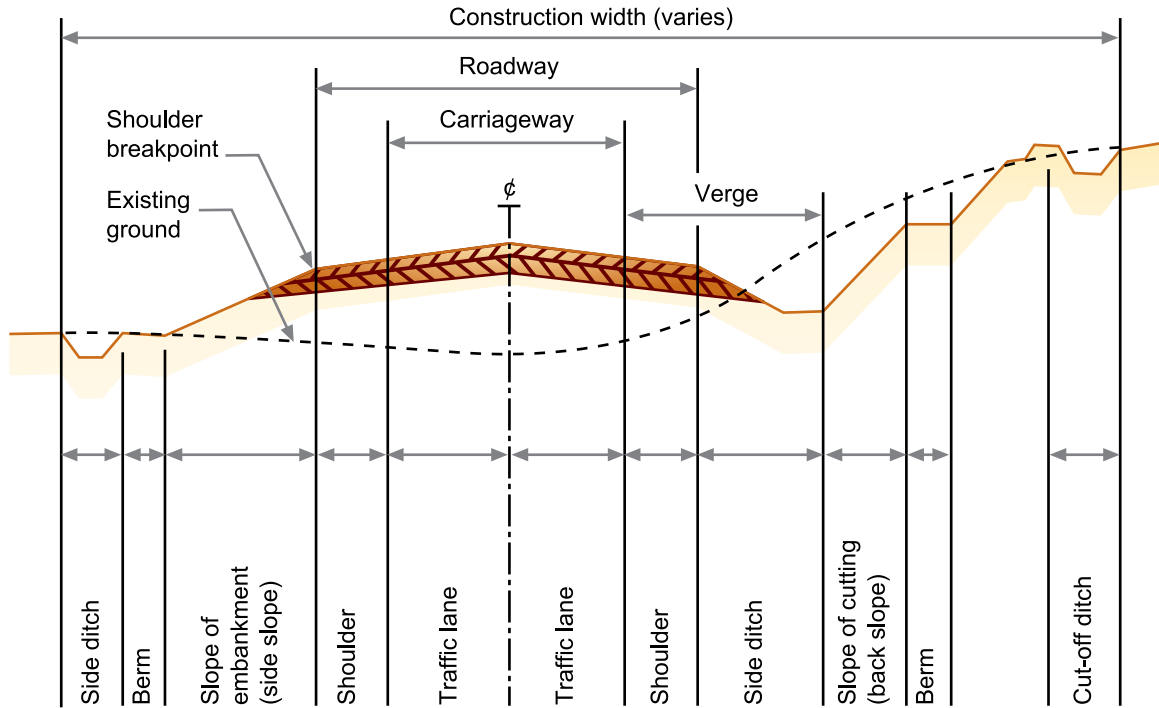

Figure 2-2: Cross section

## 2.3 Drainage Elements

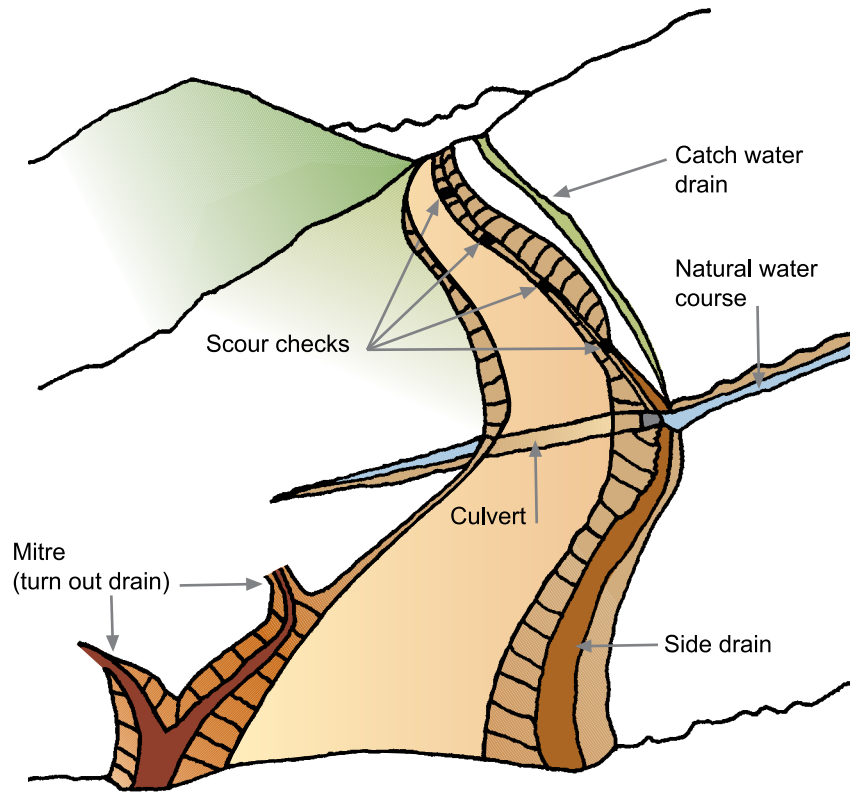

Figure 2-3: Drainage elements



Part: **B**  
**Design  
Process**

# 1. DESIGN PROCESS

## 1.1 Introduction

There are a number of steps to be followed in upgrading an unsealed road to a sealed standard. These steps constitute a design process that needs to be undertaken in a systematic and structured manner in order to produce the most appropriate design that achieves the specified functionality of the road in a cost-effective and environmentally sustainable manner. The design process must also be carried out in a manner that, at each stage, is fully responsive to the road environment in Malawi in terms of such features as the climate (rainfall and temperature), drainage, topographic and sub-soil conditions.

## 1.2 Purpose and Scope

The purpose of this chapter is to outline the design process that is followed in the *Manual* in upgrading an unpaved road to a paved standard. The various steps in the process and the main outputs of each step are summarised Figure 2-1.

## 1.3 Goal

The goal of the road design process is to produce a design that will not only achieve operational efficiency, but will also be safe and cost-effective, be aesthetically pleasing, and minimise the environmental impacts. The role of the road designer is to produce the most appropriate design that achieves the specified functionality using the design inputs from all relevant disciplines. The design must take into account all inputs from stakeholders and road users.

Whereas, previously, economics were the dominant yardstick by which roads were evaluated, we are now entering a new era, where the social, environmental and even cultural dimensions of roads are being increasingly taken into account as part of the responsible decision-making process. Today, the emphasis is on providing roads that are cost-effective and safe to use; that make maximum use of locally available materials; that employ methods of construction that maximise the use of local labour and, above all, that are sustainable in the long term through planned, affordable maintenance interventions.

Figure 1-1: Road design process

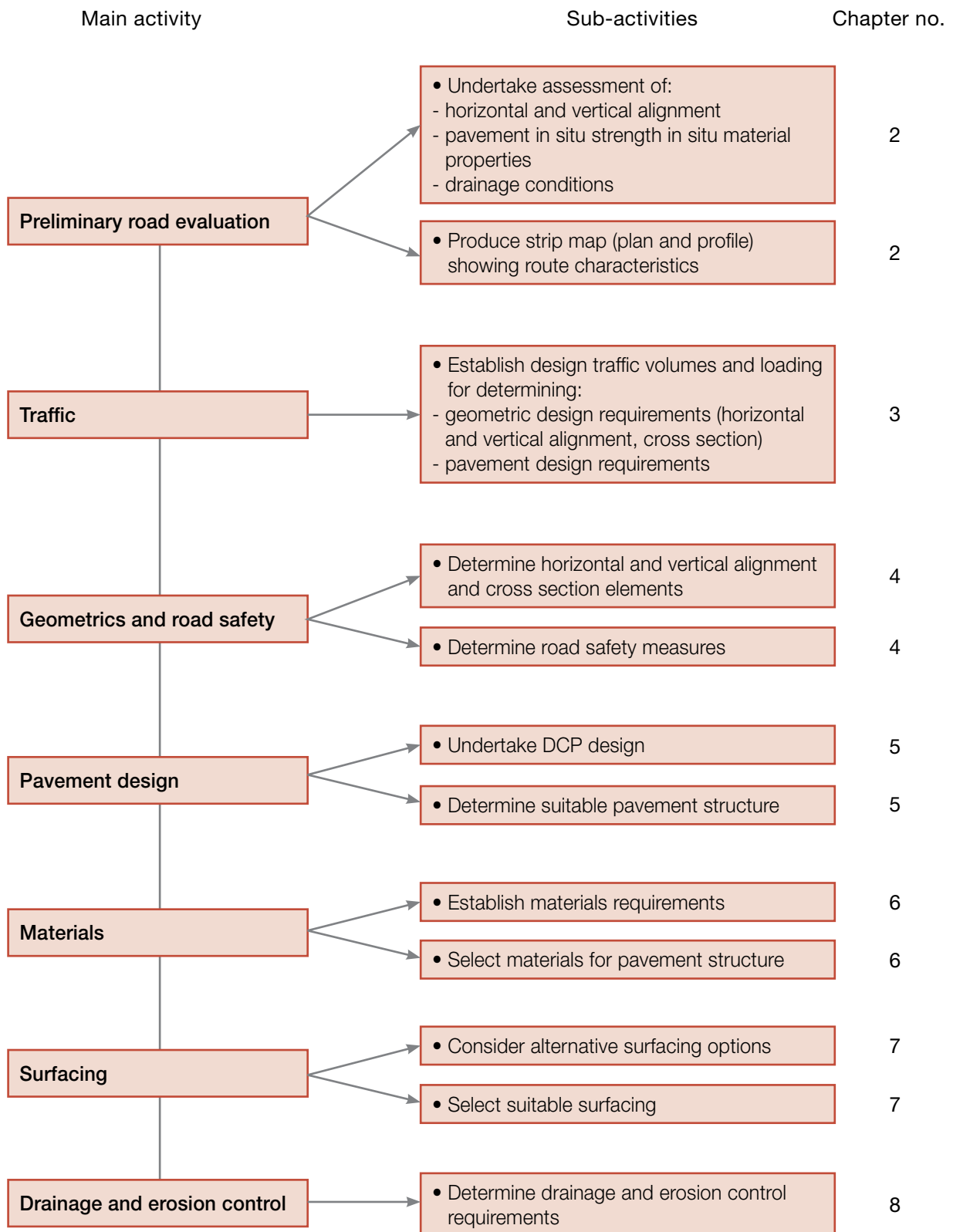

## 2. PRELIMINARY ROAD EVALUATION

### 2.1 Introduction

Information on the physical characteristics and condition of the existing gravel road and its environment are needed before its upgrading requirements can be established. A preliminary road evaluation must therefore be carried out involving appropriate investigations aimed at collecting and compiling information on the road's physical characteristics and surrounding environment as an input for subsequent decision making and design.

### 2.2 Purpose and Scope

The purpose of this chapter is to outline the scope of the preliminary road evaluation which will typically include the following stages of investigations:

- General assessment
- Visual assessment
- Structural assessment

### 2.3 General Assessment

A general assessment of the road is made by undertaking the following activities:

#### 2.3.1 Desk study

Maximum use should be made of all available information before undertaking any field surveys. Sources of information typically includes:

- Available historical data from previous construction and maintenance should be collected for review and any sections of poor alignment and accident black spots should be identified for attention in the design
- Aerial photographs from Google Earth which provide a free and very useful source of information, including a number of road environment factors such as the alignment of the road, drainage patterns, low-lying areas, locations of settlements, etc.
- Previously collected information on the location and variety of materials used in constructing the gravel road – usually available from the Central Materials Laboratory

#### 2.3.2 Consultations with local people

It is important to involve the future users of the upgraded road, including the communities served by the road. Such persons can provide valuable information on various physical characteristics, such as the likelihood of flooding of certain sections of the road, adequacy of existing culverts, the location of weak pavement layers and accident black spots.

#### 2.3.3 Geometric and road safety assessment

The geometric characteristics of the unpaved road, in terms of its horizontal and vertical alignment, will normally be retained for the paved road with minimal improvements. Nonetheless, any hazardous locations or obvious geometric shortcomings, particularly as they affect road safety, such as sharp bends combined with poor sight distance, or inadequate road markings, should be

also be noted for possible improvement including appropriate measures for producing a safer road environment (Chapter 4).

In general, traditional, full scale topographic surveys are not necessary to determine the geometric assessments indicated above. Instead, they can be achieved with the use of a simple GPS device which is sufficiently accurate for a LVR upgrading. Where drainage may be problematic, for example, at low-lying points on the road, cross-sections will be required using survey instruments.

### **2.3.4 Traffic assessment**

The type of traffic using the existing road as well as that which is likely to use the new sealed road needs to be carefully assessed. In rural areas, a wide variety of motorised and non-motorised traffic should be expected as well as a large number of pedestrians in peri-urban areas. Appropriate surveys should therefore be carried out to capture not only various types of traffic movements but also information on pedestrian crossing and pick-up points. Such information is required not only for designing the road pavement (Chapter 5) but also for considering appropriate measures for avoiding edge break/shoulder damage as well as for deciding on an appropriate cross section, including locations for provision of laybys (Chapter 4).

Any historical traffic counts available should also be obtained and can provide useful inputs to estimating future growth rates.

### **2.3.5 Climate assessment**

The characteristics of the climate such as historical annual rainfall data is to be collected as this will provide valuable information on the moisture regime in which the paved road will operate. Such information will alert the designer to the potential sources of moisture infiltration into the road pavement and the measures that should be taken to mitigate such entry.

### **2.3.6 Materials assessment and laboratory testing**

An assessment must be made of the source and availability of all materials required to upgrade the road including the surfacing, pavement layers, construction water and concrete as well as the cost implications. Every effort should be made, as far as possible, to obtain materials that are as close as possible to the road alignment so as to reduce haulage costs.

Samples of the base material, and if necessary the support layers in each uniform section, must be tested in the laboratory to provide information to aid construction and to ensure that the materials meet the relevant specifications as discussed in Chapter 6: Materials.

## **2.4 Visual Assessment**

### **2.4.1 Road condition**

A visual assessment of the road is required to determine its general condition. This is achieved by identifying any weak areas and isolated failures that require to be rectified before the pavement layer(s) and surfacing are constructed.

In flat terrain, low-lying, poorly drained areas should be noted and may require lifting the new road on to a low embankment. This will not only facilitate longitudinal drainage but also avoid saturation of the pavement by ensuring an adequate crown height relative to the invert of the side drains.

The following defects are to be noted along the length of the road for inclusion on a strip map in the manner indicated in Section 2.6.1:

- Ruts
- Shear deformation
- Potholes
- Oversize material

It is important to distinguish between those defects caused by general inadequate structural capacity of the existing pavement and those caused by poor drainage, particularly in the shoulders or outer wheel path (OWP) of the gravel road. Whereas the former will probably require increasing the structural capacity of the existing pavement, for example, by importing a new pavement layer(s), the latter defects could be rectified by improving the drainage without importing new layers. Thus, *isolated problem areas should be rectified individually rather than taking them as representative of the section*. This requires that the DCP survey be carried out in a discriminating manner

#### 2.4.2 Drainage and erosion

When a gravel road is being upgraded to a paved standard, it is important to ensure that the drainage system is functioning well. As the upgrading of major items of drainage structure such as bridges and large culverts is generally expensive, existing infrastructure should be utilised as much as possible. Where required, however, the necessary drainage infrastructure should be provided to an appropriate level as effective drainage of the road to a very large extent affects its performance and ultimate life. A thorough assessment of the existing road drainage system is therefore necessary, including the following:

- Culverts
  - Adequacy of opening (size, flooding, length of culvert)
  - Outlet conditions (ponding, silting, erosion, headwalls)
  - Structural strength (condition of concrete or other materials)
- Low level structures (causeways, drifts, etc.)
  - Adequacy of existing structure to cope with floods
  - Structural condition
  - Width
  - Erosion
- Surface drainage
  - Standing water due to rutting, etc.
- Drainage channels
  - Adequacy of side drains (shape of drain, ponding, silting, erosion)
  - Catchwater drains and cut-off drains (shape of drain, ponding, silting, erosion)
  - Mitre drains (frequency, shape of drain, ponding, silting, erosion)
- Down chutes (condition, frequency, erosion)

Erosion is closely related to drainage and depends on soil type, climate and site conditions. A general assessment of erosion potential is needed for embankments, cuttings, road reserve and borrow areas, leading to design of anti-erosion measures where necessary.

## 2.5 Structural Assessment

A pavement structural assessment is required to ascertain the strength and bearing capacity of the existing gravel road which is to be incorporated as part of the new pavement structure. The procedure for undertaking the structural assessment of the gravel road is as follows:

### 2.5.1 STEP 1: Undertake DCP survey along existing road

A DCP survey must be carried out along the full length of the road with each measurement being taken to a depth of at least 800 mm. The standard method for using the DCP is presented in Annex 2A, including a typical DCP field form.

The frequency of the DCP measurements will depend on a number of factors including the variability in road conditions and level of confidence required. The recommended frequency for upgrading a gravel road to a paved standard should be as follows, with the tests staggered at outer wheeltrack/centre line/outer wheel track (See Table 2-1):

Table 2-1: Frequency of DCP testing

Road condition	Frequency of testing/km*
Uniform (low risk)	5
Non-uniform (medium risk)	10
Low-lying/distressed (high risk)	20

\* Ensure that at least 20 DCP tests are performed per likely uniform section to provide adequate data for statistical analysis.

Care must be exercised in carrying out the DCP survey by discarding any measurements which could produce anomalous results. Such results could arise, for example, where large stones occur in the pavement layer (see Figure 2-1) which would produce misleadingly high resistance to penetration (low DN values).

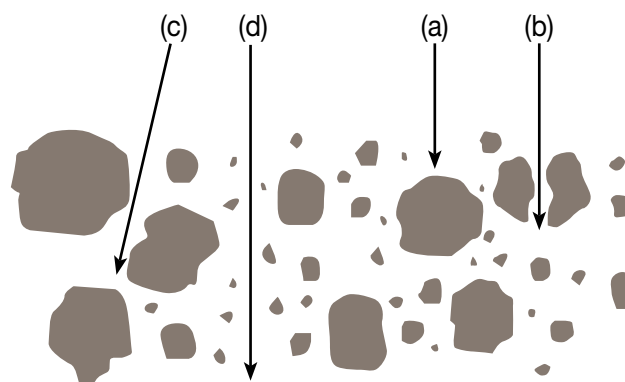

Figure 2-1: Typical DCP effects with large stones in pavement layer

#### Typical DCP effects with large stones in pavement layer:

- (a) cone cannot penetrate at all and the test needs to be re-done
- (b) cone breaks stone but penetration is characteristically hard and DSN800 is high
- (c) cone tries to push stone aside. Result is high because of side friction generated on cone shaft
- (d) Usually provides a normal result

It may sometimes be necessary to ignore the DCP readings in the top 30-50 mm of the gravel layer due to the effect of upward pushing of the material at the surface during the initial stages of the DN measurement. In such a situation, the DN values obtained would not be meaningful as they would not be reflective of the shear strength of the material.

### 2.5.2 STEP 2: Obtain DCP penetration rates in pavement layers and input results into DCP computer programme

As the inherent in situ strength of the material is strongly dependent on the prevailing moisture (and density) conditions, it is essential that an estimate of the in situ moisture condition is made at the time of the DCP survey for comparison with the expected moisture regime in service. To this end, at least 2 samples per kilometre should be obtained for moisture content determination from the outer wheel track road at depths of 0-150, 150-300 and 300-450 mm.

### 2.5.3 STEP 3: Obtain moisture content beneath pavement at time of survey.

The DCP results obtained at each measurement point must be entered into the DCP programme and the data processed, as guided, to obtain weighted average DN values (penetration rate in mm/blow), for each 150 mm layer of the pavement structure and the DSN800 value (total number of blows required to reach a depth of 800 mm).

### 2.5.4 STEP 4: Determine uniform sections

Following completion of Step 2, the DN values for each 150 mm layer as well as the DSN800 should be plotted against the chainage of the road, using a cumulative sum (CUSUM) technique to identify uniform sections along the road. This will typically identify changes in underlying materials types, transitions from cut to fill or variable soil moisture conditions. An example of the manner of determining uniform sections using the CUSUM analysis method described above is presented in Annex 2B.

### 2.5.5 STEP 5: Adjust DCP results for moisture conditions

Based on the estimate of the in situ moisture condition at the time of the DCP testing (Step 2) adjust the DCP results obtained in Step 4 in accordance with the percentile values shown in Table 2-2. It can be seen that the DCP data collected during the dry season will be relatively stronger (lower DN) than that collected during the wet season. The use of the respective 80th and 20th percentiles (design traffic < 0.5 MESA) or the 90th and 30th percentiles (traffic loading 0.5 - 1.0 MESA) effectively results in an estimate of the expected in service conditions.

Table 2-2: Percentiles of maximum DCP penetration rate to be used to assess in situ material conditions

Anticipated long-term in-service moisture content in pavement	Percentile of minimum strength profile (maximum penetration rate – DN mm/blow)	
	Design traffic < 0.5 MESA	Design traffic 0.5 – 1.0 MESA
Drier than at time of DCP survey	20	30
Same as at time of DCP survey	50	65
Wetter than at time of DCP survey	80	90

The in situ moisture content tends to be a function of the height of the pavement layer(s) above natural ground level, adjacent cuttings, material properties and the depth of the water table below natural ground level. Given a conducive moisture regime (see Section 8.4), after surfacing the moisture content in the base tends to stabilise to equilibrium at typically 70 – 90% of OMC.

An example of the application of the above table to determine an appropriate percentile value of the minimum in situ strength profile of the pavement that should be used for design purposes is provided in Annex 2C.

### 2.5.6 Interpretation of results

The designer should not undertake the DCP design of a road as a desk exercise. For proper interpretation of the DCP results, the designer needs to be intimately familiar with the ground conditions at the time of the survey. The DCP survey should be complemented with a visual condition survey (see Section 2.6.1) in which the designer must be involved in order to obtain a proper “feel” for or “understanding” of for the road that is being designed.

## 2.6 Strip Maps

In order to provide a good “picture” of the existing unpaved road in terms of the key road environment factors that may affect the design of the paved road, a strip map should be produced. The details included in this linear map will assist with the application of the Environmentally Optimised Design (EOD) approach to the design of the road (See Annex 2D). The map will also be of assistance to the designer in terms of showing such features as access roads, lay-bys/bus stops etc for which particular attention should be given in terms of side drainage and visibility as well as to the contractor in preparing his tender. Such a map would normally obviate the need for a more traditional and expensive detailed topographic road survey that can hardly be justified for a low volume road.

The following items should be included on the strip map which is illustrated in Annex 2E.

### 2.6.1 Road cross section

The cross section describes the profile of the road relative to the natural ground level in terms of the following:

- Embankment
- Level
- Depression
- Cutting

### 2.6.2 Road condition

The condition of the existing gravel road generally reflects a number of factors affecting its performance such as gravel quality, pavement bearing capacity, moisture regime and drainage. For example, severely distressed sections are often located in areas where the gravel quality is poor and/or the road level may be low and/or drainage is poor. The in situ conditions must be catered for in the final design.

During the visual assessment, the road condition should be rated into the following four categories based on the degree and extent of the occurrence as described in Annex 2D.

Band A:	Good	- Few defects
Band B:	Fair	- Few defects with degree of defects seldom severe
Band C:	Poor	- General occurrence of particular defects with degree of severe
Band D:	Very poor	- Many defects. The degree of the majority of defects is severe and the extent is predominantly general to extensive

### 2.6.3 Traffic

Information on traffic volumes will influence both the pavement design (type of surfacing, thickness and quality of pavement materials) and the geometric design (width of pavement and shoulders) of the road.

Motorised traffic should be categorised and colour coded into the following bands:

Band A:	< 75 vpd
Band B:	76-150 vpd
Band C:	151-300 vpd
Band D:	> 300 vpd
Band D:	> 15% (Very steep)

### 2.6.4 Vertical gradient

The vertical gradient will influence a number of design parameters including type of surfacing and drainage requirements. This parameter can be determined by means of a GPS and should be categorised and colour coded into the following bands:

Band A:	< 3% (Flat)
Band B:	3-7% (Moderate)
Band C:	7-15% (Steep)
Band D:	> 15% (Very steep)

### 2.6.5 Pavement strength (bearing capacity)

The pavement bearing capacity (DSN<sub>800</sub>) provides a good indication of the existing strength of the unpaved road to a depth of 800 mm as obtained from the DCP survey. This parameter should be determined for each uniform section and colour coded into the following bands of relative bearing capacity :

Band A:	DSN <sub>800</sub> = > 200 (very high)
Band B:	DSN <sub>800</sub> = 151-200 (high)
Band C:	DSN <sub>800</sub> = 101-150 (moderate)
Band D:	DSN <sub>800</sub> = <100 (low)

### 2.6.6 Drainage features

The following drainage features should be shown against the chainage of the road:

- Drainage structures
- Direction and angle of water flow
- High points
- Low points
- Possible locations of mitre drains

## ANNEX 2A: Use of the DCP

Attention should be paid to the following issues when using the DCP.

- The equipment must be held vertically at all times. Any deviation from the vertical will result in difficulties in getting repeatable readings from the measuring staff. In addition, the friction effects between the falling mass and the upper rod reduce the energy imparted to the cone
- The hammer must touch the base of the handle before being released, without jolting the equipment vertically. The hammer should be released to fall under its own mass and not “thrown” down
- When testing “hard” materials, the hammer will often bounce a number of times on the anvil before coming to rest. It should not be lifted for the next drop before coming to total rest
- The test should start with the upper portion of the shoulder of the cone flush with the surface of the layer being tested
- During testing, it is common to note that uplift or mounding of the layer around the DCP hole occurs. This may result in a gradual rise of the measuring staff relative to the equipment and hence a reduction in the reading being obtained. Care should be taken that the base of the measuring staff is not affected by this “mounding”
- The cones will suffer from wear and deformation, particularly when testing hard materials, and need to be replaced periodically. Prior to any test, the condition of the cone should be checked to ensure that the point is sharp, the whole cone is screwed into the shaft and the lower surface is not excessively rough (see Photograph 2A-1). High tensile or tempered cones are not recommended as they tend to shear off when striking a hard stone



**Photo 2A-1: Typical cones and problems**

*(From left to right: disposable cone, conventional cone, worn cone tip, worn cone, incorrect cone with shoulder too wide, 30° cone)*

Figure 2-1: Typical DCP Field Form and Example Measurements

DCP Test Measurements							
Project Name: Nchisi Road							
<b>Chainage (km):</b> 0.060				<b>Surface Type:</b> Unpaved			
<b>Direction:</b> West				<b>Thickness (mm):</b> -			
<b>Location/offset:</b> Lane 1/ 2.00 m				<b>Base type:</b> Natural gravel (laterite)			
<b>Zero Error (mm):</b> 44 mm				<b>Thickness:</b> 120 mm			
<b>Test date:</b> 06.08.2010				<b>Surface Moisture:</b> Dry			
No.	Blows	Cumulative Blows	Penetration Depth (mm)	No.	Blows	Cumulative Blows	Penetration Depth (mm)
1	0	0	44	26	5	125	379
2	5	5	62	27	5	130	388
3	5	10	72	28	5	135	411
4	5	15	86	29	5	140	426
5	5	20	93	30	5	145	441
6	5	25	101	31	5	150	460
7	5	30	115	32	5	155	478
8	5	35	131	33	5	160	497
9	5	40	148	34	5	165	510
10	5	45	166	35	5	170	519
11	5	50	183	36	5	175	546
12	5	55	202	37	5	180	563
13	5	60	222	38	5	185	578
14	5	65	238	39	5	190	597
15	5	70	259	40	5	195	610
16	5	75	271	41	5	200	629
17	5	80	288	42	5	205	643
18	5	85	300	43	5	210	684
19	5	90	310	44	5	215	710
20	5	95	321	45	5	220	736
21	5	100	332	46	5	225	758
22	5	105	341	47	5	230	790
23	5	110	358	48	5	235	830
24	5	115	365	49	5		
25	5	120	372	50	5		

## ANNEX 2B: Example of Determination of Uniform Sections from CUSUM Analysis

### 1. CUSUM Analysis

Chainage (km)	B Measured DCP (DN Value -mm/blow)	C Difference from average (A-B)	CUSUM (Accumulated values of C)
1	14	-1.2	-1.2
2	13	-0.2	-1.4
3	15	-2.2	-3.6
4	14	-1.2	-4.8
5	13	-0.2	-5.0
6	14	-1.2	-6.2
7	7	5.8	-0.2
8	9	3.8	3.4
9	8	4.8	8.2
10	13	-0.2	8.0
11	15	-2.2	5.8
12	18	-5.2	0.6
13	14	-1.2	-0.6
14	16	-3.2	-3.8
15	14	-1.2	-5.0
16	14	-1.2	-6.2
17	15	-2.2	-8.4
18	18	-5.2	-13.6
19	14	-1.2	-14.8
20	15	-2.2	-17.0
21	9	3.8	-13.2
22	10	2.8	-10.4
23	9	3.8	-6.6
24	12	0.8	-5.8
25	9	3.8	-2.0
26	11	1.8	-0.2

Average: A = 12.8mm/blow

## 2. Uniform sections

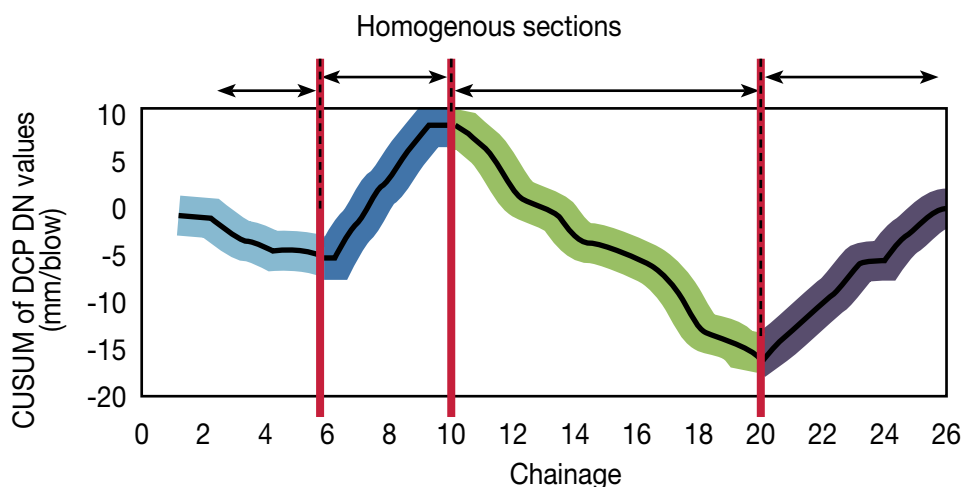

## ANNEX 2C: Determination and Choice of DN Percentile Values

### 1. DCP Survey results - DCP Survey results–Uniform section derived from CUSUM analysis of DN 150 (Base)

(N.B. DN 0-150 = DN in first 150mm of pavement.)

Chainage (km)	Point No	DN 150 (Base) (mm/blow)	Percentile of minimum strength profile (max. penetration rate – DN mm/blow)		
			20th	50th (Mean)	80th
0.00	1	2.29			
0.25	2	4.44			
0.50	3	2.00			
0.75	4	8.67			
1.00	5	3.75	3.46**	5.24	8.19
1.25	6	8.07			
1.50	7	5.11			
1.75	8	5.37			
2.00	9	6.60			
2.25	10	10.12			
Anticipated long-term in-service moisture content in pavement*					
Drier than at time of DCP survey			3.46	N/A	N/A
Same as at time of DCP survey			N/A	5.24	N/A
Wetter than at time of DCP survey			N/A	N/A	8.19

\* This is one of the most carefully considered decisions the designer will have to make to ensure that a reliable DCP design is achieved. See Section 2.5.5 for the basis on which the decision should be made.

\*\* The percentile value in an Excel spreadsheet may be obtained from the expression: =PERCENTILE(N\$1:N\$10,0.2) where N is the column containing the DN values.

### 2. Definition of percentile

A percentile of a range of values is the point in the range at or below which a given percentage of values is found. For example, the 80th percentile of the distribution of DN values given in the above example is the point at or below which 80% of the values fall, i.e. 8.19, as illustrated below.

DN value	% ile*	DN %ile (mm/blow)	Anticipated long-term in-service moisture content in pavement
2.00 2.29 3.75 4.44	20th	3.36	Drier than at the time of DCP survey
5.11 5.37 6.60	50th	5.24	Same as at time of DCP survey
8.07 8.67 10.12	80th	8.19	Wetter than at time of DCP

\* %ile value may need to be adjusted for the design traffic loading as indicated in Table 2-2.

## ANNEX 2D: Sample of Strip Map

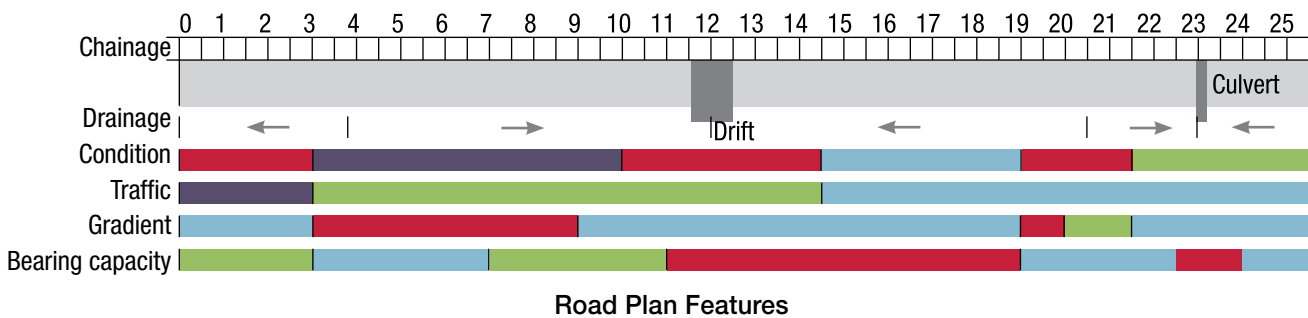

Legend			
<b>Condition</b>	Good	<b>Traffic</b>	< 75 vpd
	Fair		76-150 vpd
	Poor		151-300 vpd
	Very poor		> 300 vpd
		<b>Gradient</b>	< 3%
			3 – 7%
			7 – 10%
			> 10%
		<b>Bearing capacity (DSN<sub>800</sub>)</b>	> 200
			151-200
			101-150
			<100

## ANNEX 2E: Evaluation of Condition of Existing Gravel Road

### General approach

The assessment of the condition of the existing gravel road is based on functional descriptors in which various attributes of distress are described in terms of type, degree and extent of occurrence for each assessment segment, i.e. the length of road for which one assessment rating is recorded (typically 1 km). During the survey the rating team (typically two raters) should travel along the road at no more than 20-25 km/hr, and stopping at least one within every kilometer.

### Types of distress

The types of distress to be recorded are as follows:

- Ruts
- Corrugations
- Gravel thickness loss
- Potholes

### Degree of distress

The degree of a particular type of distress is a measure of its severity and should be the best average assessment of the seriousness of a particular type of distress. The general descriptions of degree of each type of distress are presented below.

Degree	Severity	Description
1	Slight	Distress just discernible
2	Moderate	Distress is distinct
3	Severe	Distress is significant
4	Very severe	Distress is extreme

The rating of the various types of distress shall be as follows:

Rating	Ruts (Depth mm)	Corrugations (Depth mm)	Gravel Thickness (mm)	Potholes (Number)
Good	< 25	< 25	125 – 150	< 5
Fair	25 - 50	25 - 50	75 – 125	5 – 15
Poor	50 - 75	50 - 75	50 – 75	15 – 25
Very poor	> 75	> 75	< 50	> 25

### Extent of distress

The extent of distress is a measure of how widespread the distress is over the length of the road segment. The general descriptions of extent of each type of distress are presented below.

Extent	Description
1	No or isolated occurrence over parts of the segment length
2	Intermittent (scattered) occurrence, over significant parts of the segment length or extensive occurrence over a limited portion of the segment length
3	More frequent occurrence over a major portion of the segment length
4	Extensive occurrence over most of the segment length

### Overall condition

The description of the overall condition of the gravel road is based on its composite rating which reflects the raters assessment of the average degree and extent of each distress type as presented in the table below.

Rating	Description
1 = Good	Few defects
2 = Fair	Few defects with degree of defects seldom severe. Extent is only local if degree is severe
3 = Poor	General occurrence of particular defects with degree of severe
4 = Very poor	Many defects. The degree of the majority of defects is severe and the extent is predominantly general to extensive

### Example of assessing overall road condition

Assment Segment		Distress Assessment								Overall Condition
		Ruts		Corrugations		Gravel Thickness		Potholes		
Start	Finish	Degree	Extent	Degree	Extent	Degree	Extent	Degree	Extent	
0.00	0.05	3	1	2	2	1	2	2	1	2 = Fair
0.05	0.10	4	3	4	4	4	3	4	3	4= V. poor

Whereas the assessment of the various types of distress is based on reasonably quantitative criteria, that for the overall condition assessment is based more on a qualitative assessment of the individual ratings.

## 3. TRAFFIC

### 3.1 Introduction

Reliable information on traffic volumes and patterns is essential for different aspects of the road design process, including:

- **Geometric design:** For geometric design purposes, the volume and composition of traffic, both motorised and non-motorised, influence the cross section design (carriageway and shoulders)
- **Pavement design:** The deterioration of sealed roads caused by traffic results from both the magnitude and frequency of individual axle loads. Thus, pavement design requires information on the total number of commercial vehicles which will use the road and their axle loads
- **Road safety:** The volume, type and characteristics of the traffic using the road will all influence the type of road safety measures required to ensure a safe road environment, particularly with regard to catering for the requirements of vulnerable road users, including non-motorised traffic and pedestrians

### 3.2 Purpose and Scope

The objective of this chapter is to provide the procedures required for estimating the design traffic loading as outlined in Figure 3-1.

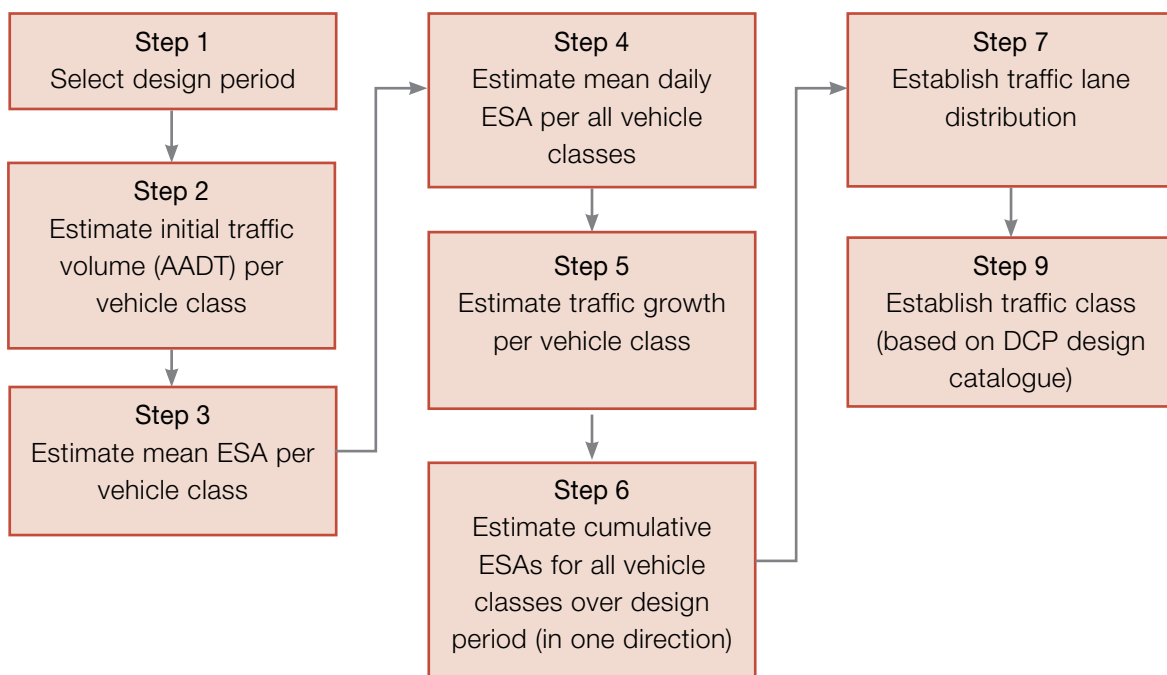

Figure 3-1: Procedure for establishing design traffic class

### 3.3 Procedure for Estimating Design Traffic

#### 3.3.1 STEP 1: Select design period (Step 1)

A structural design period must be selected, over which the cumulative axle loading is determined for the basis of the pavement design. Such a period is defined as the time span in years considered appropriate for the road pavement to function before reaching a terminal value of accepted serviceability after which major rehabilitation or reconstruction would be required. In addition to its role in estimating the quantum of the design traffic for pavement design purposes, the design period also forms the basis for expectations of how the constructed pavement will perform. Thus, it is expected that a certain amount of maintenance work will need to be carried out in order to meet the design life.

Figure 3-2 illustrates the definition of the design period in relation to its terminal serviceability level (e.g. riding quality (roughness) or rutting).

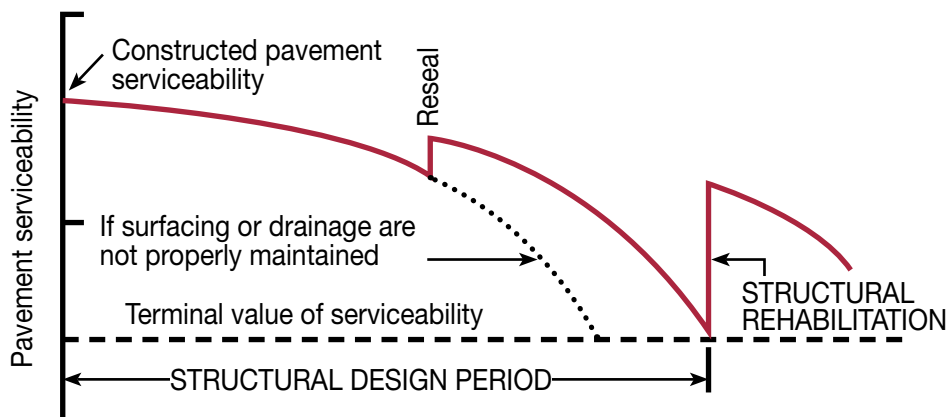

Figure 3-2: Structural design period

The various factors that influence the choice of design period include:

- The strategic importance of the road (i.e. its classification)
- Maintenance strategies (highly trafficked facilities will demand long periods of low maintenance activity)
- Funding considerations
- The anticipated time for future upgrading of the road
- The likelihood that factors other than traffic, e.g. a highly reactive subgrade, will cause distress necessitating major rehabilitation in advance of any load-related distress

Based on the above factors, Table 3-1 provides guidance on the selection of the structural design life. Choosing a relatively short design life reduces the problem of long-term traffic forecasting whilst choosing a relatively long design life requires greater care in estimating the design traffic loading if over/under-design of the pavement, and the related cost implications, are to be avoided.

Table 3-1: Structural design period

Design data reliability	Importance/level of service	
	Low	High
Low	10 yrs	10 - 15 yrs
High	10 - 15 yrs	15 - 20 yrs

### 3.3.2 STEP 2: Estimate initial traffic volume per vehicle class

This is determined on the basis of appropriate traffic surveys to establish the traffic volume by each traffic class in terms of the Annual Average Daily Traffic (AADT) at the time of the road opening. In arriving at the AADT, cognisance should also be taken of the possibility of diverted traffic (existing traffic that changes from another route) and generated traffic (traffic generated from the development).

The two most commonly used types of traffic surveys for LVRs are:

- Automatic Traffic Survey (traffic counters with inductive loops and weighing-in-motion (WIM) sensors)
- Manual Traffic Survey

The objective of undertaking either of the above types of traffic surveys is essentially to obtain an estimate of the AADT using the road, disaggregated by vehicle type. Prediction of such traffic is notoriously imprecise, especially where the roads serve a predominantly developmental or social function. Thus, the timing, frequency and duration of traffic surveys should be given very careful consideration in terms of striking a balance between cost and accuracy.

Errors in estimating traffic for LVSRs can be reduced by conforming to the following rules:

- Count for seven consecutive days
- On some days count for a full 24 hours, preferably with one 24-hour count on a weekday and one during a weekend; on other days, 16 hour counts (typically 06.00 – 22.00 hours) should be made and expanded to 24 hour counts using a previously established 16:24 hour expansion ratio
- Avoid counting at times when road travel activity increases abnormally; for example, just after the payment of wages and salaries, or at harvest time, public holidays or any other occasion when traffic is abnormally high or low
- If possible, repeat the seven-day counts several times throughout the year  
Care should be exercised in selecting appropriate locations for conducting the traffic counts to ensure a true reflection of the traffic using the road and to avoid under- or over-counting. If any junctions occur along the road length, counts should also be conducted before and after the junctions and the turning movements of buses and trucks recorded to guide the selection of road width and type of seal at those areas

All traffic, both motorised and non-motorised, is grouped into one of twelve categories as shown in Table 3-2 for subsequent capacity analysis for cross-section and surfacing design and axle load analysis for pavement design.

Table 3-2: Vehicle classification for traffic counts

Vehicle Classification												
1	2	3	4	5	6	7	8	9	10	11	12	13
Car	Pick-up	4WD	Minibus	Large bus	Med. bus	LGV	MGV	HGV	Tractor	Motor Cycle	Bicycle	Animal cart
Capacity analysis				Axle load analysis					Capacity analysis			

The definitions of the commercial vehicle classification shall be as in Table 3-3:

Table 3-3: Commercial vehicle classification

- Large bus	Seating capacity of 40 or more
- Medium bus	Seating capacity of 28 or more
- Light Goods Vehicle (LGV)	2 axles, including steering axle ≤ 3 tonnes empty weight
- Medium Goods Vehicle (MGV)	2 – 5 axles, including steering axle ≥ 3 tonnes empty weight
- Heavy Goods Vehicle (HGV)	6 or more axles, including steering axle ≥ 3 tonnes empty weight

### 3.3.3 STEP 3: Estimate mean ESA per vehicle class (VEF)

Static axle load data on the vehicles expected to use the road is required to determine the mean axle load Equivalence Factor (EF) and, subsequently the mean Vehicle Equivalence Factor (VEF), i.e. the sum of the axle load EFs for each vehicle. Such data should preferably be obtained from surveys of commercial vehicles using the existing road or, in the case of new roads on new alignments, from existing roads carrying similar traffic. Where project specific axle load surveys are not carried out, recourse may be made to historical information.

The axle load EF is determined from converting the surveyed axle loads to ESAs/axle and then deriving a representative weighted average value for each vehicle class. In some cases, there will be distinct differences in each direction and separate EFs should be derived for each direction.

The EF (ESAs) is derived as follows:

$$EF = [W/8160]^n \text{ (for loads in kg) or } = [W/8.16]^n \text{ (for loads in tonnes)}$$

where  $W$  = axle load (in kg or kN)

$n$  = power exponent

and the standard axle load is taken as 8160 kg or 8.16 tonnes

In the DCP design method, the value of “ $n$ ” has been found to be affected by the composition of the pavement structure in terms of its “*balance*” which influences the load *sensitivity* of the pavement. Moreover, the exponent “ $n$ ” is related to the Pavement Balance Number, BN (the number of blows to penetrate the top 12.5% of the pavement as a percentage of the number required to penetrate 800 mm), through the derived model which is illustrated in Figure 3-3. (See Chapter 5 and Annex 5A).

For LVSRs, which are commonly constructed from granular materials in both the base course and

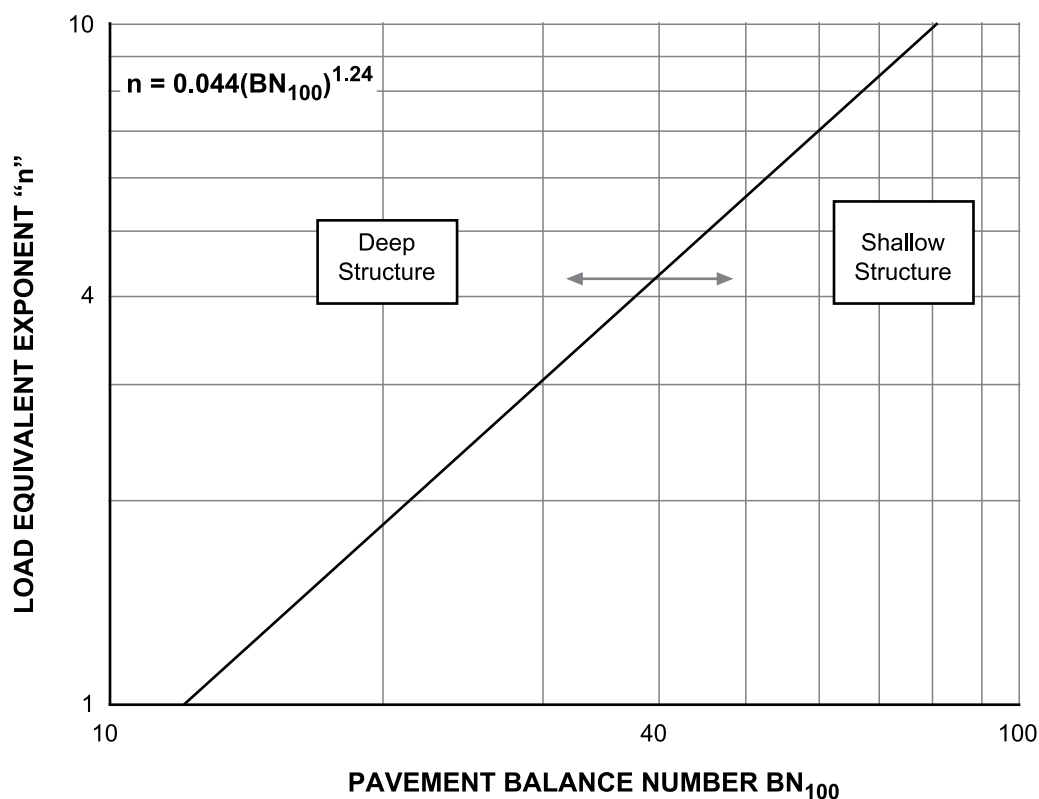

Figure 3-3: Relationship between BN100 and load equivalent exponent (n) for strength-balanced pavements

improved subgrade, the mean BN value of the existing pavement should be determined for each uniform section from which the related damage exponent “n” can be obtained from Figure 3-3 for use in determining the design traffic loading for the section. However, the minimum recommended value of n is 3.

### 3.3.4 STEP 4: Estimate mean daily ESA for each vehicle class

The estimated mean daily ESAs for each vehicle class (DESA) is obtained from the traffic data derived in Step 2 and the VEFs derived in Step 3 as follows:

$$- \text{DESA} = \text{AADT} \times \text{VEF}$$

### 3.3.5 STEP 5: Estimate traffic growth per vehicle class

Following the establishment of the baseline traffic, further analysis is required to establish the total design traffic based on forecast of traffic growth in each vehicle class. To forecast such growth, it is first necessary to sort traffic in terms of the following categories:

- **Normal traffic** – that which pass along the existing road in the absence of its upgrading to a higher standard
- **Diverted traffic** – that which changes from another route to the project road, but still travels between the same origin and destination points
- **Generated traffic** – additional traffic that occurs in response to the new or improved road

The methods typically used for determining normal, diverted and generated traffic are presented in Annex 3A.

### 3.3.6 STEP 6: Estimate cumulative ESA (CESA) for all vehicle classes over the design period (in one direction)

The one-directional design traffic loading, i.e. the cumulative equivalent standard axles (CESA), for each traffic category expected over the design life may be obtained from the following formula:

$$\text{CESA} = 365 \times \text{DESA} \times [(1 + r)^N - 1]/r$$

where DESA = mean daily ESAs for each vehicle class in the first year (one direction)  
(From Step 4)

r = assumed annual growth rate expressed as a decimal fraction (From Step 5)

N = design period in years (from Step 1)

The total CESA for all vehicle classes is then obtained from summing the CESA for each vehicle class.

### 3.3.7 STEP 7: Establish traffic lane distribution

The actual design traffic loading (ESAs) needs to be corrected for the distribution of heavy vehicles between the lanes in accordance with Table 3-4.

Table 3-4: Lane width adjustment factors for design traffic loading

Cross Section	Paved width	Corrected design traffic loading (ESA)	Explanatory notes
Single carriageway	< 3.5 m	Double the sum of ESAs in <u>both</u> directions	The driving pattern on this cross-section is very channelised.
	Min. 3.5 m but less than 4.5.m	The sum of ESAs in <u>both</u> directions	Traffic in both directions uses the same lane
	Min. 4.5 m but less than 6 m	80% of the ESAs in <u>both</u> directions	To allow for overlap in the centre section of the road
	6 m or wider	Total ESAs in the <u>heaviest</u> loaded direction	Minimal traffic overlap in the centre section of the road.
More than one lane in each direction		90% of the total ESAs in the <u>studied</u> direction	The majority of vehicles use one lane in each direction.

### 3.3.8 STEP 8: Establish traffic class for pavement design

For pavement design purposes, it is necessary to determine which traffic class the roads falls into. Based on the DCP design catalogue, the design traffic classes are designated as follows:

**Table 3-5: Designated traffic classes for pavement design**

Traffic Class	Cumulative Number of ESAs (CESA – one direction)
LE 0.01	0.003 – 0.01
LE 0.03	0.01 – 0.03
LE 0.10	0.03 – 0.10
LE 0.30	0.10 – 0.30
LE 0.70	0.30 – 0.70
LE 1.0	0.70 – 1.0

If estimates of cumulative traffic are close to the boundaries of the traffic ranges, then the basic traffic data and forecasts should be re-evaluated and sensitivity analyses carried out to ensure that the choice of traffic class is appropriate. Such an analyses would consider minimum/maximum values for such key variables as traffic growth, VEF and design period.

## ANNEX 3A: Determination of Normal, Generated and Diverted Traffic

**Normal traffic:** Different methods may be used to forecast normal traffic. These include:

- (a) **Growth related to GDP** - traffic growth can be related directly to growth in Gross Domestic Product (GDP). This forecasting method is preferable because it refers to changes in overall economic activity. However, it requires a reliable GDP forecast. If this is not available, forecasts should be based on time series data as described below.
- (b) **Extrapolation of time series data** - the most common form of traffic forecasting, this uses estimates based on past traffic growth trends. Linear extrapolations assume growth rate will remain constant in absolute terms; constant elasticity extrapolations assume constancy in relative (percentage increase) terms. Fuel sales data may be used as an indicator of national traffic growth, though improving fuel efficiency must be considered. Time series extrapolations should not exceed the length of time of either the historical data or reliably predictable economic conditions.
- (c) **Differential growth rates** – where a particular component of traffic grows at a different rate, it should be specified and separately considered. Housing or factory developments, for example, can affect road traffic growth rates and composition.

**Diverted traffic:** Such traffic is typically forecast to grow at the same rate as traffic on the road from which it was diverted. Assignment of diverted traffic is normally done by an “all or nothing” method. Here the assumption is that all vehicles which would save time or money by diverting will do so. With this method, it is important that all perceived user costs are included.

**Generated traffic:** Such traffic is generally difficult to forecast accurately and can easily be over-estimated. It is likely to be significant only in those cases where the road investment brings about large reductions in transport costs. For example, small improvements in an existing developed road system, or over short lengths of road are unlikely to create substantial generated traffic.

Generated traffic is best determined from demand relationships in which the price elasticity of demand for transport reflects the responsiveness of traffic to a change in transport costs following a road investment. This elasticity ranges typically from - 0.6 to - 2.0 with an average of about -1.0. This means that a one per cent decrease in transport costs leads to a one percent increase in traffic.

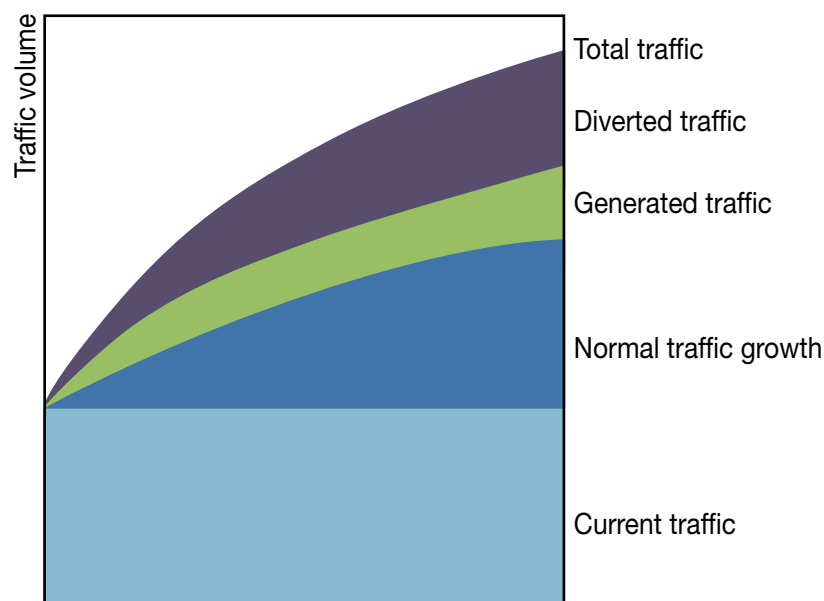

Figure 3B-1: Traffic Development of an Improved Road

In summary, estimating traffic growth over the design period is very sensitive to economic conditions and prone to error. It is therefore prudent to assume low, medium and high traffic growth rates as an input to a traffic sensitivity analysis for pavement design purposes.

## ANNEX 3B: Design Example: Determination of Traffic Design Loading

### A. Design inputs:

1. Design Life = 20 years
2. Road width = 5m (surfaced shoulder breakpoint-to-shoulder breakpoint)
3. A 7-day traffic count summary (AADT both directions) is as follows:

Day	Car	Pick-up	4WD	Mini-bus	Large bus	Med.	LGV	MGV	HGV	Tractor	Motor cycle	Bicycle	Animal cart
Mon	65	14	10	4	1	2	9	1	0	1	11	81	1
Tue	55	12	8	4	2	4	11	2	0	2	12	69	2
Wed	60	10	6	5	2	4	7	1	0	1	11	57	1
Thu	72	13	7	6	3	8	9	3	0	1	15	63	3
Fri	80	18	12	8	2	4	6	2	0	2	25	80	3
Sat	95	20	15	10	3	10	25	4	0	7	20	52	4
Sun	50	9	7	6	1	3	10	1	0	2	15	42	1
ADT	68	14	9	6	2	5	11	2	0	2	16	63	2

4. Vehicle growth rate = 4.5% average for all vehicle classes:
5. Vehicle equivalence factors as follows:

Vehicle Type	VEF (ESA/vehicle)
Large bus	1.2
Medium bus	0.8
LGV	1.0
MGV	1.5
HGV	3.5

6. Pavement Balance Number BN = 38 (from which damage exponent  $n = 4$ )

## B: Design calculations

### 1. Estimation of mean daily ESA (DESA) per all vehicle classes

- Large bus	2 x 1.2	= 2.4
- Medium bus	5 x 0.8	= 4.0
- LGV	11 x 1.0	= 11.0
- MGV	2 x 1.5	= 3.0
- HGV		= 0
Total ESA/day		= 20.4 (both directions)

### 2. Estimation of Cumulative ESAs (CESA) for all vehicle classes over design life

The design CESA can be computed from the following equation:

$$\begin{aligned}
 \text{CESA} &= 365 * \text{DESA} * [(1 + r)^N - 1]/r \\
 &= 365 \times 20.4 \times [(1 + 0.045)^{20} - 1]/0.045 \\
 &= 365 \times 20.4 \times [(1.045)^{20} - 1]/0.045 \\
 &= 365 \times 20.4 \times [2.411 - 1]/0.045 \\
 &= 365 \times 20.4 \times 31.3 \\
 &= 233,059 \text{ ESA} \\
 &= 0.23 \text{ Million equivalent standard axles (MESA) (both directions)}
 \end{aligned}$$

### 3. Estimation of corrected design traffic loading for 5 m wide road:

- Corrected design traffic loading	= 80% of ESAs in both directions (ref. Table 3-4)
	= 0.80 x 0.23 MESA
	= 0.18 MESA

### 4. Establishment of design class for pavement design

- Traffic falls within CESA range 0.10 – 0.30 (after undertaking sensitivity analyses to evaluate changes in assumptions regarding variables such as VEF, growth rates, etc.)
- Design traffic class = LV 0.30

## 4. GEOMETRICS AND ROAD SAFETY

### 4.1 Introduction

In principle, the aim of geometric design is to provide an alignment which is the best compromise between operational efficiency, safety and economy. However, the lightly trafficked characteristics of LVSRs mean that upgrading improvements should be planned at the lowest practicable standards if costs are to be justified by benefits obtained. Thus, the challenge faced by the designer is to provide for all road users so that they can travel safely on the road versus practical and cost considerations on the ground.

### 4.2 Purpose and Scope

The purpose of this chapter is to provide guidance on the approach that should be adopted in evaluating the adequacy of the geometrics and road safety characteristics of the existing alignment. The chapter does not deal with the various factors affecting the choice of geometric standards or details of alignment design (horizontal and vertical curvature, etc.) which are outside the scope of the manual. Instead, the chapter focuses on the following elements of the existing gravel road in the context of their adequacy for retention in the new paved road..

- Geometrics
  - cross-section
  - horizontal alignment
  - vertical alignment
- Road safety
  - road safety measures

### 4.3 Geometrics

#### 4.3.1 Cross-section

The various elements of a LVSR cross-section are illustrated Figure 4-1. Each of these elements can influence not only the capacity of the road, but also its safety, integrity (in terms of its drainage adequacy) and, ultimately, its structural performance. The adequacy of the existing cross-section must therefore be evaluated against the minimum requirements so that, where necessary, carefully considered improvements can be made, bearing in mind the cost implications against the benefits to be derived.

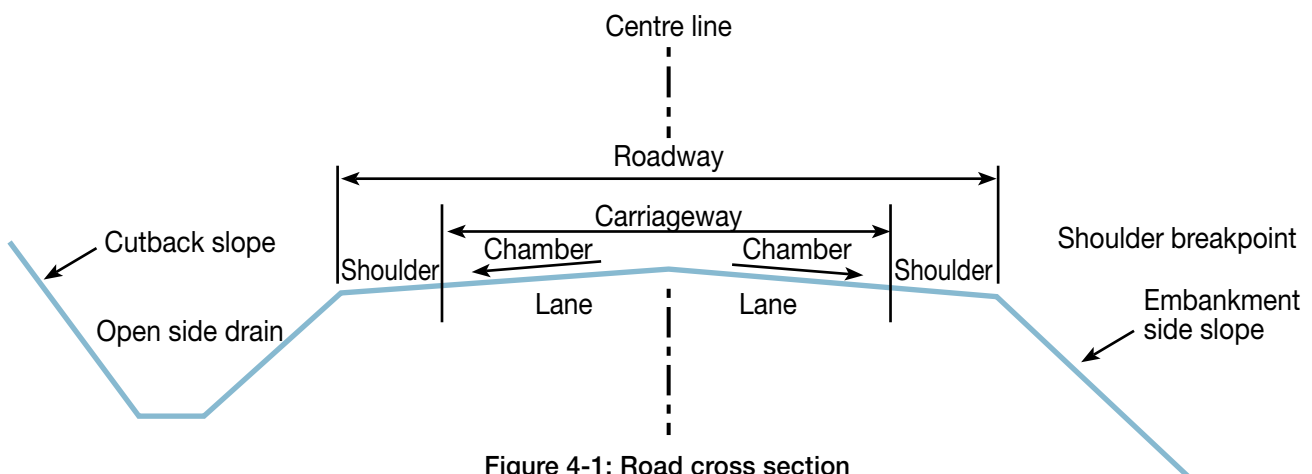

Figure 4-1: Road cross section

Of particular importance in assessing the adequacy of the roadway width is the issue of catering simultaneously for the requirements of both motorised and non-motorised traffic as well as pedestrians. Typically recommended values for the cross-section elements for various classes of LVSRs are presented in Table 4-1 and provide a yardstick against which the adequacy of the existing gravel road cross-section may be assessed.

**Table 4-1: Typically recommended roadway widths**

Traffic flow (AADT)	Roadway width (m)		
	Carraigeway	Shoulder	Total
150-300	6.0 – 6.5	2 x 1.25	8.5 – 9.0
75-150	5.5 – 6.0	2 x 1.0	7.5 – 8.0
< 75	3.0 – 3.3*	2 x 1.5	6.0 – 6.3

\* essentially a single lane road with wide shoulders

- (a) **Roadway:** The width of the roadway (carraigeway plus shoulders) has a large effect on construction costs and should be minimised subject to operational and safety criteria. In principle, enough overall width should be provided for two design vehicles to pass each other safely, if necessary at low speed in steep terrain.

If severe roadway width constraints exist, for example in urban or peri-urban areas, then lesser roadway widths than indicated in Table 4-1 may be acceptable, particularly at the lower end of the traffic range in each traffic class and, in addition, if the shoulders are sealed and the incidence of NMT is low. In such cases, consideration can be given to adapting the side drainage arrangements to economise on space constraints, with the use of either covered or uncovered, U-type, brick-lined drains.

- (b) **Shoulders:** Shoulders fulfill a variety of functions in the operation of LVSRs including:
- Structural
    - to allow wide vehicles to pass each other safely on relatively narrow roads
  - Safety
    - to provide safe room for temporarily stopped or broken down vehicles
    - to allow pedestrians, cyclists and other vulnerable road users to travel safely
  - Drainage
    - to allow rain water to drain from within the pavement layers
    - To reduce the extent to which water flowing off the surface can penetrate into the pavement (e.g. by extending a seal over the shoulder)

Sealing of shoulders is recommended as it offers numerous advantages over unsealed shoulders including:

- They provide better support and moisture protection for the pavement layers and also reduce erosion of the shoulders (especially on steep gradients)
- They improve pavement performance by ensuring that the zone of seasonal moisture variation does not penetrate under the outer wheel track
- They reduce maintenance costs by avoiding the need for regravelling at regular intervals
- They reduce the risk of road accidents, especially where the edge drop between the shoulder and the pavement is significant or the shoulders are relatively soft

- (c) **Camber and cross-fall:** In order to shed water effectively off the roadway, the minimum normal cross fall shall be not less than 3%, including shoulders where they have the same surface as the carriageway.
- (d) **Side slopes:** Side slopes should be designed to ensure the stability of the roadway and to provide a reasonable opportunity for recovery if a vehicle goes out of control across the shoulders. In addition, the position of the side drain invert should be a reasonable distance away from the road to minimise the risk of infiltration of water into the road if the drain should be full of water for any length of time. Figure 4-2 illustrates the layout of the side slopes within the road cross section.

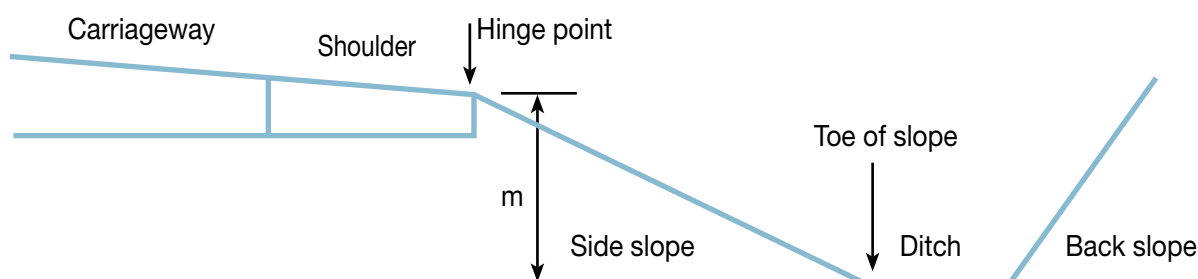

Figure 4-2: Details of road edge

Table 4-2 indicates the side slope ratios recommended for use in the design of the side and back slopes which is dependant on the type of material and the height of cuts and fills.

Table 4-2: Safety of slopes (vertical:horizontal)

Type of Material	Height of Slope (m)	Side slope		Back slope	Safety classification
		Cut	Fill		
Soil	0.0 - 1.0	1:4	1:4	1:3	Recoverable
	1.0 - 2.0	1:3	1:3	1:2	Not recoverable
	>2.0	1:2	1:2	1:1.5	Critical
Rock	Any angle	Dependant on costs			Critical
Expansive clay	0.0 - 2.0	n/a	1:6		Recoverable
	>2.0	n/a	1:4		

### 4.3.2 Horizontal alignment

The over-riding principle to be followed is that the horizontal alignment should largely dictate the speed and not vice-versa, i.e. major costs should not be incurred merely to provide a fully, design speed-related, alignment. Thus, the existing alignment should be used as much as possible. Extreme bends (usually > 135° and gradients (usually > 12%) may at the discretion of the engineer require correction on grounds of safety.

### 4.3.4 Vertical alignment

The vertical alignment should be retained as much as possible, subject to an over-riding need to ensure that the crown height of the road is at least 0.75 m above the invert of the longitudinal drain.

## 4.4 Road Safety

### 4.4.1 General measures

Road safety is of primary importance for all road users in Malawi whether they are travelling on LVSRs or more highly trafficked trunk roads. There appears to be no statistical evidence to indicate that accident rates on LVSRs are much different to HVRs and it has become apparent that the core problem is unacceptable driver behaviour which needs to be addressed, irrespective of the type of road.

It has also become apparent that the safety concerns of LVSR users are different to those of HVSR users. This is largely because there tends to be a much higher incidence of vulnerable road users (NMT, pedestrians and animals) on LVSRs than on HVSRs. The challenge in such a situation is to ensure that the speed of motorised traffic is restrained to relatively low levels, particularly within villages. This is not easily achieved because the roads serving these villages often serve two conflicting functions in that they cater for both inter- and intra-village traffic. As a result, specific speed reduction measures are required to minimise traffic accidents. Such measures may be achieved in a number of ways including:

- Appropriate road signage, including traffic signs and road markings
- Use of well designed road humps and rumble strips in and around villages and other danger spots, such as very sharp bends
- Pedestrian crossings in urban and peri-urban areas
- Use of shoulder humps to deter drivers from using the road shoulders
- Use of relatively wide shoulders ( $\pm 1$  m), especially in built-up areas

The context specific application of the above measures requires the development of a “*total village treatment*” with the objective of instilling in the driver a perception that the village is a low-speed environment in which driving speed should be reduced. This concept, which is increasingly being adopted successfully in a number of countries, is elaborated upon in Annex 4A.

### 4.4.3 Road safety audits

Because of the paramount importance of road safety on LVSRs, a road safety audit should be undertaken as part of the preliminary road evaluation process (ref. Chapter 2). Such an audit should systematically identify hazardous features, including accident “black spots” and the accident potential related to the improvement/upgrading of the road, and should propose treatments that will reduce crash risk to road users. Site specific remedial treatments should be identified and prioritised for early implementation, based on the risks identified at the audit stage. In addition to the road safety audit, road safety education and enforcement should be given high priority in order to promote a road safety “culture” for road users of all ages in the country.

## ANNEX 4A: Speed Reduction Measures in Villages

### 1. Introduction

Speed reduction measures in villages require special attention. This is because the roads serving these villages are often required to serve two conflicting functions in that they must cater for both inter- and intra-village traffic. As a result, traffic entering the village often does so at speeds that are much too high for a village environment where there is slow moving turning traffic, parking outside shops and stalls and the needs of pedestrians who require to move along or across the road. Such a situation requires the need for a comprehensive “village treatment” which will induce a driver to reduce speed significantly as he or she passes through a village.

### 2. Total village treatment

The objective of this is to develop, in the driver, a perception that the village is a low-speed environment and to encourage him to reduce speed as a result of this perception. To this end, the road through the village is treated as being in three zones, namely:

- (i) The approach zone
- (ii) The transition zone
- (iii) The core zone

#### 2.1 The Approach Zone

This is the section of road prior to entry into the village, where the driver needs to be made aware that the open road speed is no longer appropriate. This is the section of road where speed should be reduced typically from 80 km/h down to 50 km/h, before entering the village. The village entry should be marked by a **Gateway** as described later in this annex.

#### 2.2 The Transition Zone

This is the section of road between the village entrance, or Gateway, and the core zone of the village. The target speed, and posted speed limit in this zone would be typically 50 km/h. The first road hump or humps in a series of humps will be sited in this zone. In this context, with adequate advance warning provided by the approach zone and Gateway, road humps are quite safe.

#### 2.3 The Core Zone

This is the section identified as being in the center of the village, where most of vehicle/pedestrian conflict would be expected to take place. This would normally be where any shops are sited, bus-bays or other pedestrian generating activity. This is the section where pedestrian crossing facilities are most likely to be established and where the target speed, and posted speed limit, should typically be 40 km/h. Road humps would normally be provided within this zone with advisory speed limits of 20 km/h in order to enforce the lower speed environment required.

#### 2.4 Typical Village Treatment

A typical treatment, showing the three zones outlined above, is illustrated in Figure A-1. The elements which make up the village treatment are as follows:

- 1) **Roadway bar markings:** These are used in the approach zone as the initial warning to the driver that a speed reduction is required. They are painted on the carriageway immediately in advance of the village entry point or Gateway (Figure A-2).

- 2) **The gateway:** This marks the main entrance to the village and is a clear indication to the driver that the road is now changing in character at this point as an additional encouragement to reduce speed. Details of the Gateway are shown in Figure A-3.
- 3) **Rumble strips:** These are used as warning devices to drivers to reinforce the fact that the road through the village has been narrowed (Figure A-4).
- 4) **Road humps:** These are the main self-enforcing means of producing a speed reduction. There are two types of humps as follows:
  - a) **Watts profile hump** which has been designed to provide the required reduction in speed while at the same time providing a reasonably comfortable ride for passengers and the least damaging effect on vehicles when travelling at the advisory speed (Figure A-5).  
The specific purpose of the Watts profile hump is to lower traffic speeds. As such, it is most useful as a back-up to the gateway so that drivers have little option but to slow down before reaching the core zone. For this reason, the first hump in a series of humps should always be a Watts profile hump, and should always be sited in the transition zone, i.e. between the Gateway and the core zone.
  - b) **Flat-top hump** (see Figure 4B.2): The top portion of this hump is flat with a ramp on either side at a grade of 1:15. The height of the hump is 100 mm and the minimum width of the flat section (measured along the road centre line) is 3.7 metres (Figure A-6).

The flat-top hump will generally be used at locations within the core zone of the village where there is the greatest pedestrian demand. In this situation, the hump may be combined with a pedestrian crossing, which would be sited on the flat part of the hump.

The recommended spacing and combination of road humps is shown in Figure A-7.

- 5) **Pedestrian crossings:** Such crossings can be expediently combined with flat-top humps by locating them on the flat top of the hump which itself is located in the core zone of the village and has been designed to provide a safe crossing place for pedestrians, as well as functioning as a speed retarder.
- 6) **Traffic signs and road markings:** These are used to provide warning information to motorists at all elements of the village treatment, such as at entry to the Gateway, at the start and exit of the core zone, in advance of road humps, advising speeds, etc.
- 7) **Bus-bays and shelters:** These should generally be provided in the core section of the village and should be in pairs. They should be located back-to-back, i.e. when there is a bus in each bay, they should be facing away from each other so that passengers leaving a bus and then crossing the road, will be behind a bus parked on the opposite side, and will not be crossing in front of it.
- 8) **Pedestrian routes:** The aim should be to identify the major pedestrian routes within the village, to determine at what point they join the road, and whether any realignment is necessary to ensure that pedestrians are led to appropriate crossing places. The main pedestrian route within a village should always join the road within the core zone.

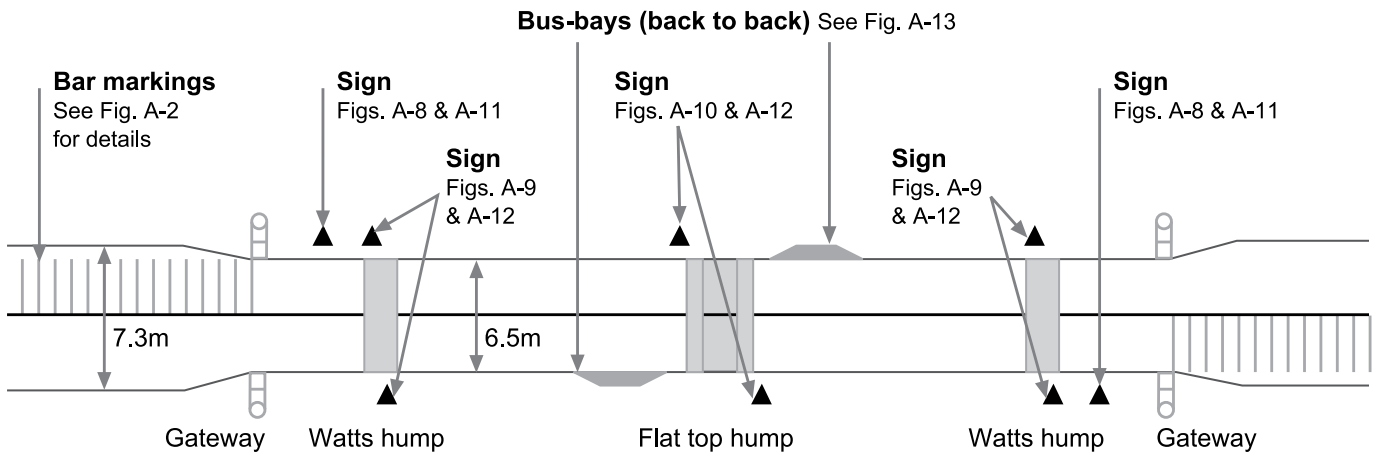

Notes:

1. Layout not to scale.
2. Road cross-section dimensions and speed limits are indicative only and should be amended to suit site conditions and traffic regulations.

Figure 4A-1: Village treatment - typical layout with approach, transition and core zones and posted speed limits

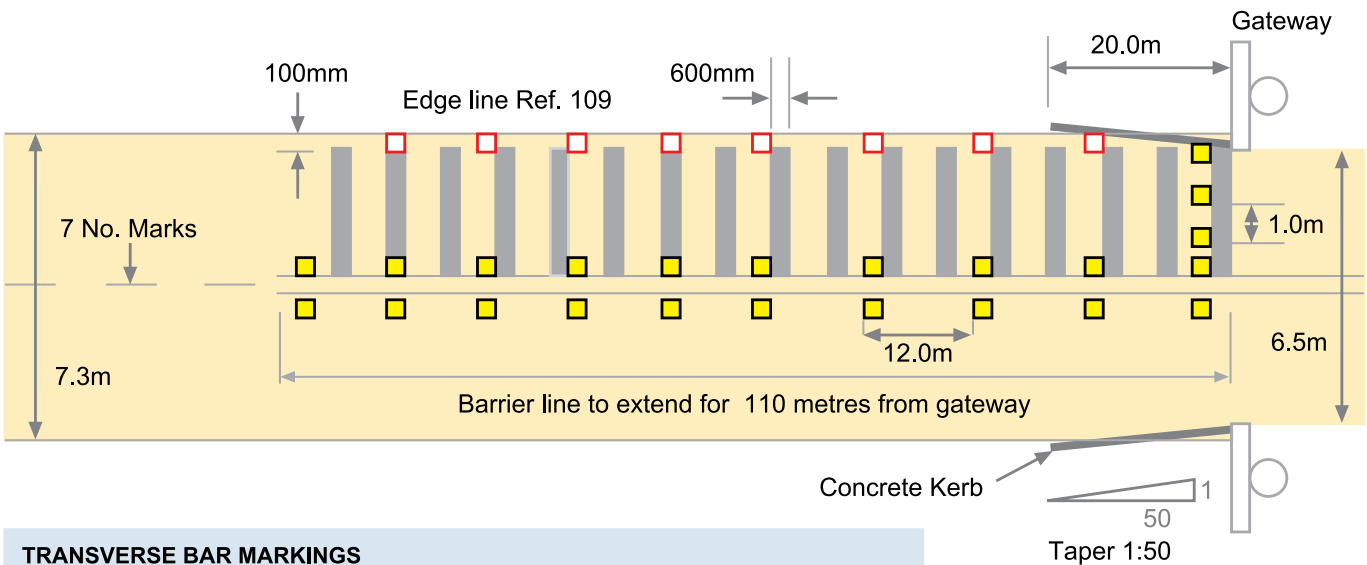

TRANSVERSE BAR MARKINGS							
Bar No.	Distance	Bar No.	Distance	Bar No.	Distance	Bar No.	Distance
1	0	6	28.5	11	60.0	16	95.0
2	5.5	7	34.5	12	66.5	17	102.5
3	11.0	8	40.5	13	73.5		
4	16.5	9	47.0	14	80.5		
5	22.5	10	53.5	15	87.5		

■ RPRM Yellow bi-directional  
□ RPRM Yellow uni-directional  
*Not drawn to scale*

Figure 4A-2: Village Treatment - Transverse bar marking and retro-reflective pavement markers (RPRM) in approach zone

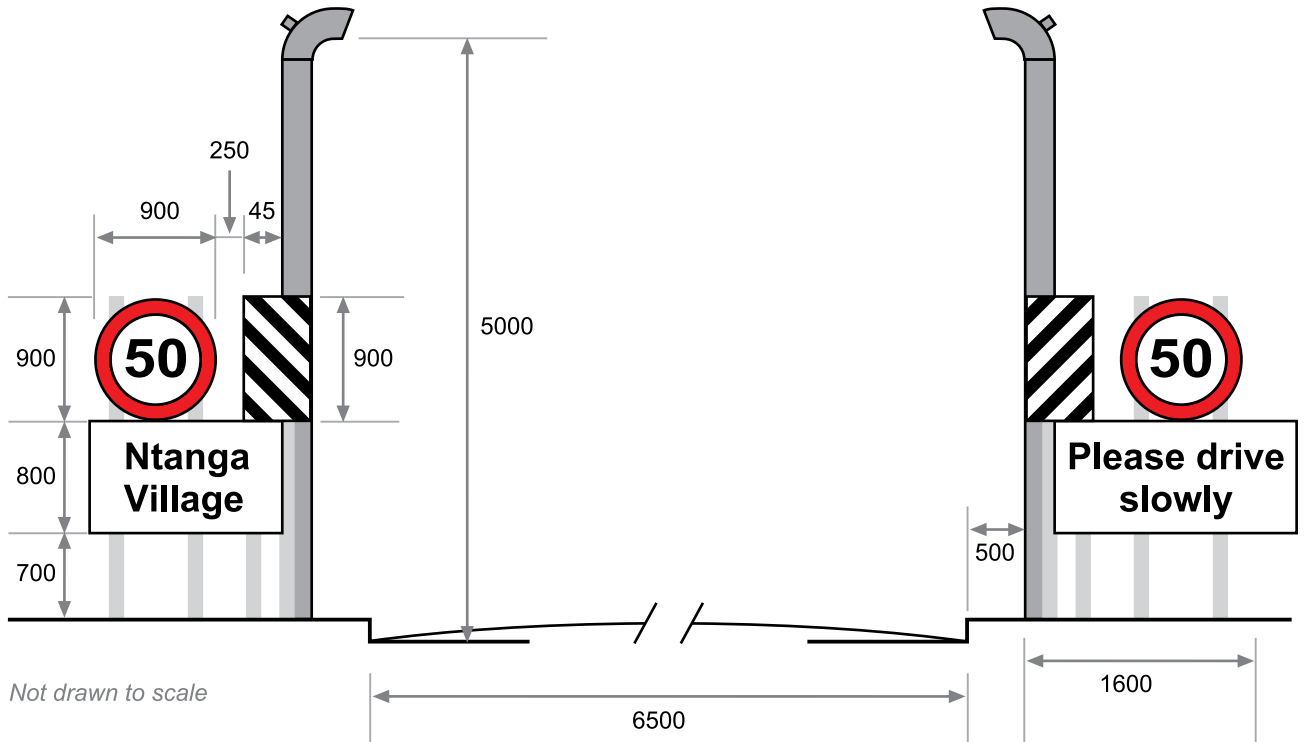
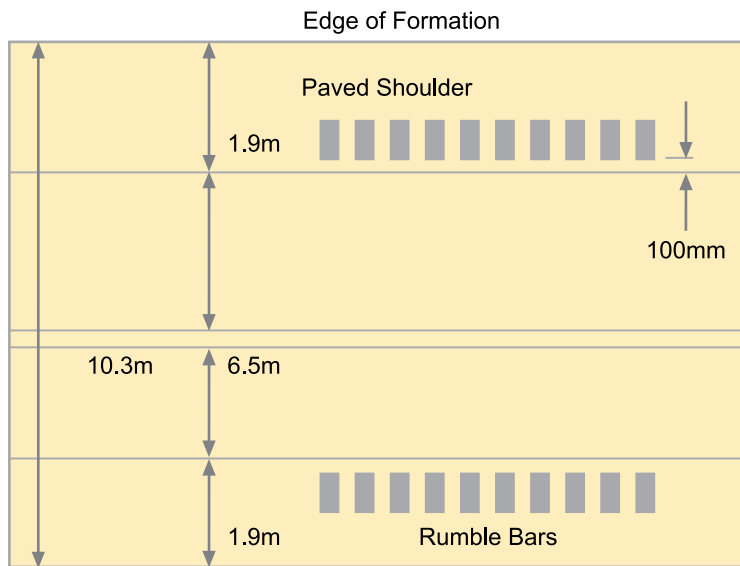
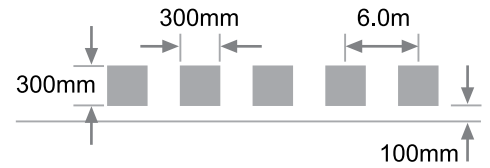

Figure 4A-3: Village treatment – gateway approach to village



TYPES OF RUMBLE BAR: MAX. HEIGHT = 25mm

1 Asphalt may be built up in layers to produce a thickness of between 15mm and 25mm. See note 3.



2 Precast concrete blocks with beveled edges.

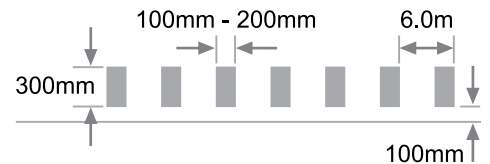

3 River boulders may be set in concrete

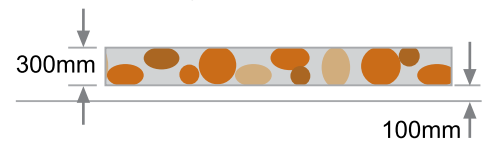

- Note:**
- 1 Distance shown for spacing of successive bars is for guidance only and should be subject to trials for types 1 and 2. Type 3 is continuous.
  - 2 Length of each series of bars, and location, to be determined on site with a view to reminding the driver of the reduced width of road.
  - 3 The height of bars may vary between 15mm and a maximum of 25mm and should be subject to trials for each of the selected materials.

Figure 4A-4: Village treatment: rumble bars

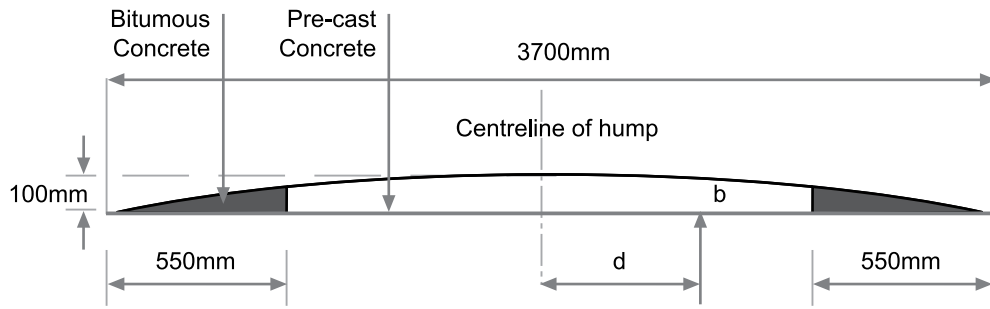

<b>d (mm)</b>	0	100	200	300	400	500	600	700	800	900	1000	1100	1200	1300	1400	1500	1600	1700	1800
<b>b (mm)</b>	100	100	99	97	95	93	90	86	81	76	71	65	58	51	43	34	25	16	5

**CROSS SECTION A-A**

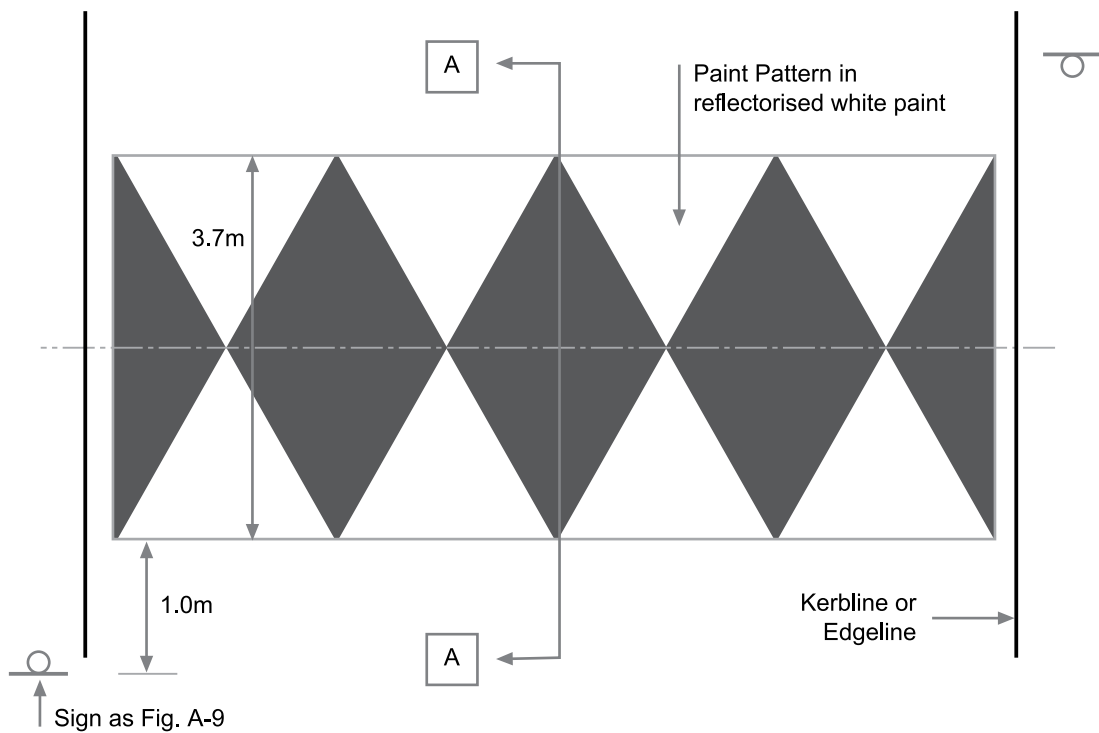

Figure 4A-5: Village treatment – Watts profile hump

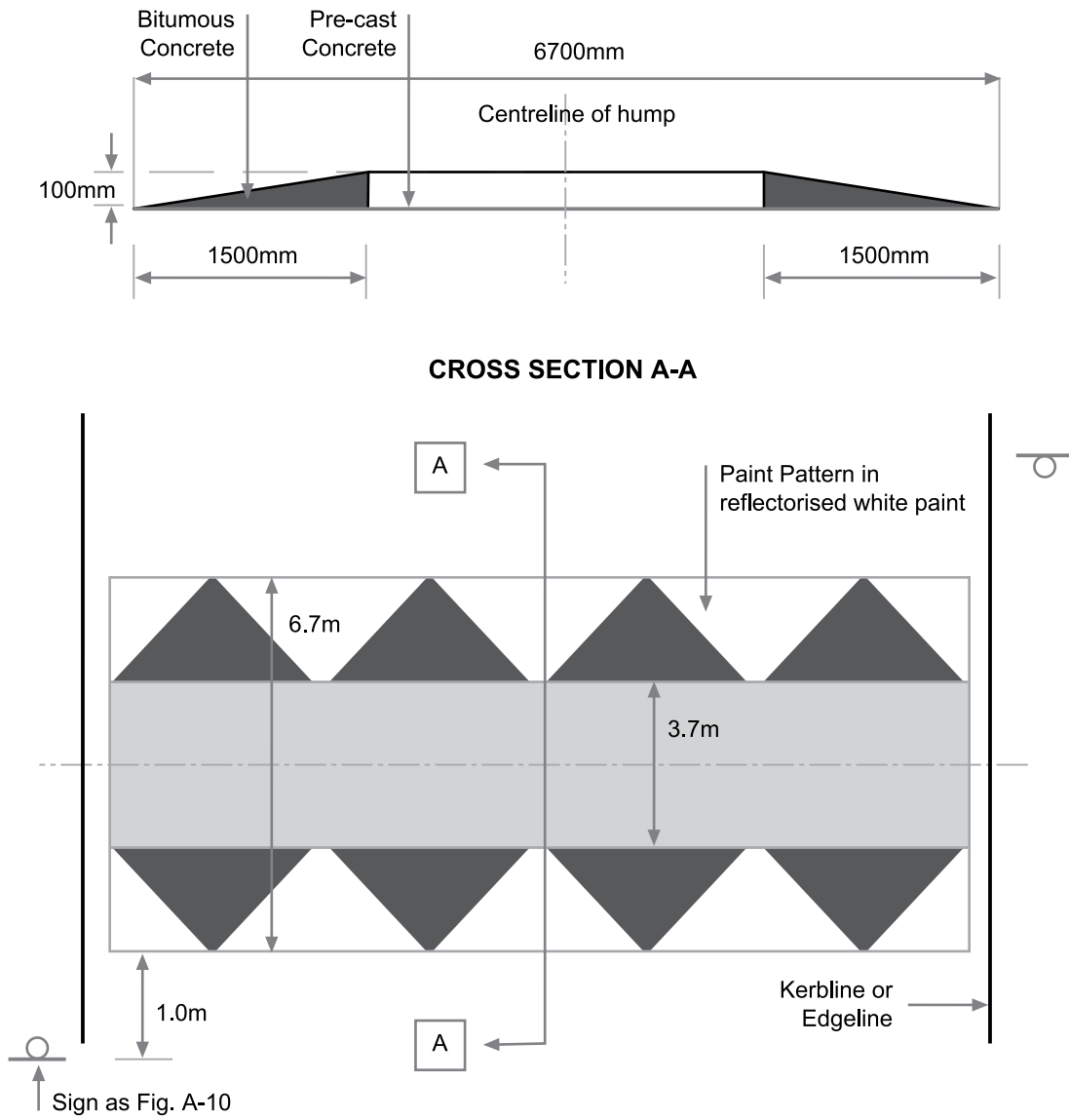

Figure 4A-5: Village treatment – Watts profile hump

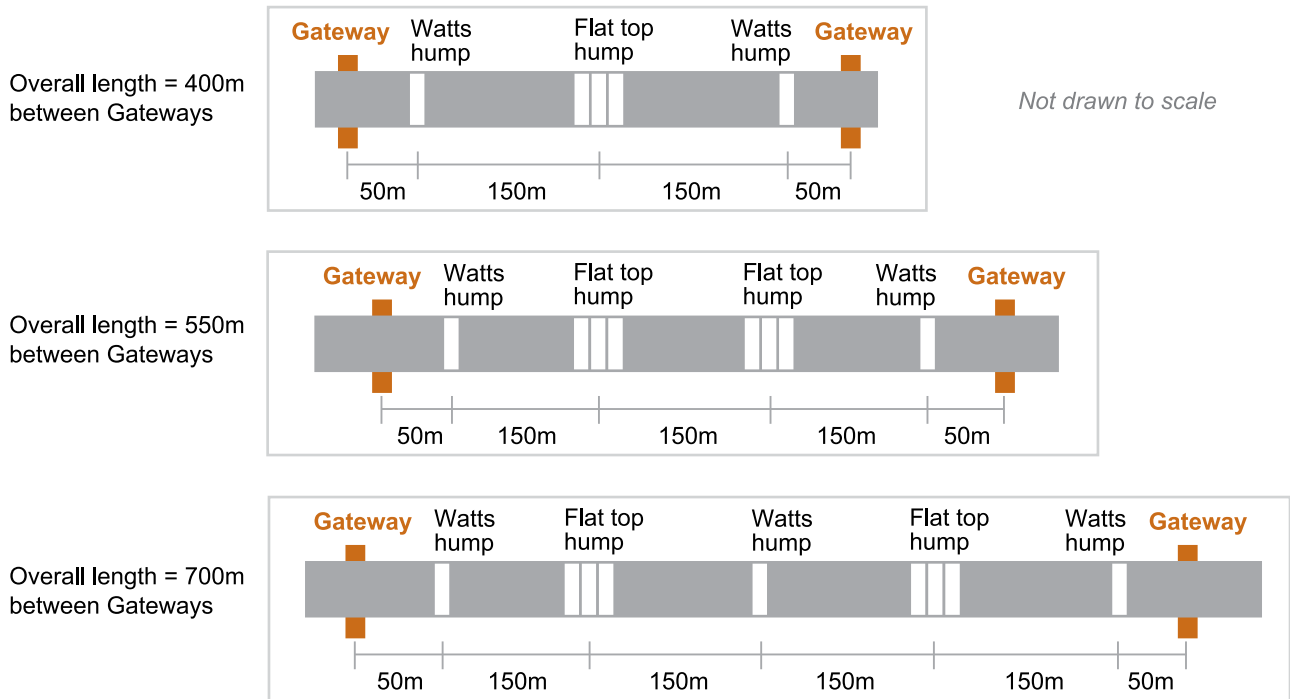

Figure 4A-7: Village treatment: Typical spacing and combination of road humps



**Figure 4A-8:**  
(To be used with plate shown in Figure A-11)



**Figure 4A-9:**  
(To be used with plate shown in Figure A-12)



**Figure 4A-10:**  
(To be used in with plate shown in Figure A-12)



Figure 4A-11:  
Plate for use with sign shown in Figure A-8



Figure 4A-12:  
Plate for use with sign shown in Figures 9 and 10

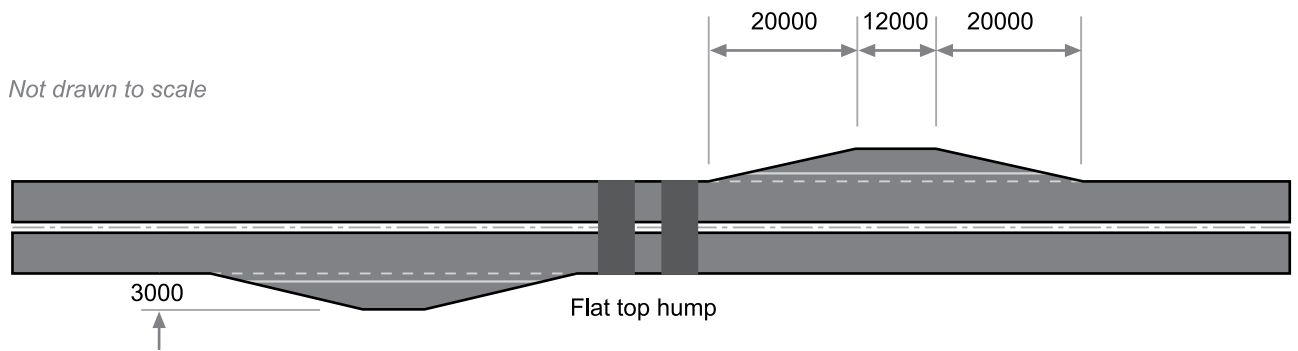

Figure 4A-13: Village treatment – back-to-back bus-bays with flat top hump

## 5. PAVEMENT DESIGN

### 5.1 Introduction

In order to upgrade an unsealed road to a sealed standard as cost effectively as possible, optimal use must be made of the in situ materials within the prevailing road environment. As a result of undergoing many years of trafficking, coupled with climatic wetting and drying cycles, the unsealed road would have achieved a significant degree of subgrade compaction, localised areas would have been strengthened and an accumulation of residual gravel wearing course over the years would provide a sound support or foundation for the new road. Optimising the use of these conditions usually results in a reduced need to import large quantities of virgin material by only adding a new layer (s), if necessary, to cater for the design traffic.

### 5.2 Purpose and Scope

The main purpose of this chapter is to present the design procedure to be followed in upgrading an unpaved road to a LVSR standard, based on the use of the Dynamic Cone Penetrometer (DCP) method. The chapter presents the background to the development of the DCP design method, provides an overview of the design approach, outlines the procedure to be followed in designing LVSR roads and highlights the advantages and limitations of the method. A pavement design example is presented in Annex A.

### 5.3 Background to the DCP Design Method

The original development of the DCP dates back to the mid-1950s in Australia based on an older Swiss original, and was used initially as a non-destructive testing device to evaluate the shear strength of a material in a pavement. The use of the DCP for pavement design purposes was further enhanced in the mid-1960s and 1970s in South Africa where results from back analysis of some 57 roads in different traffic and climatic environments, together with some accelerated pavement testing with the Heavy Vehicle Simulator (HVS) were used to verify the concepts used in the design method and to establish expected life versus DCP penetration curves.

During the mid 1980s, a formal computerised method was developed for the DCP bringing in new concepts and methodologies. The simplicity and ease of use makes the DCP ideally suited for designing the upgrading of gravel roads to a paved standard. One of the major advantages of the test is that the pavement is tested in the condition at which it performs. The simplicity of the test allows repeated testing to minimise errors and also to allow for temporal effects.

### 5.4 Design Principles

#### 5.4.1 Design philosophy

The philosophy behind the DCP design method is to achieve a balanced pavement design whilst also optimising the utilisation of the in situ material strength as much as possible. This is achieved by:

- 1) Determining the design strength profile needed
- 2) Integrating the strength profile with the in situ strength profile

To utilise the existing gravel road strength, the materials in the pavement structure need to be tested for their actual in situ strength, using a DCP. This instrument has been designed to provide a rapid, relatively low-cost, non-destructive method of estimating the in situ strength of fine-grained and granular subgrades, base and sub-base materials and weakly cemented materials.

### 5.4.2 DCP number (DN)

The DCP measures the penetration per blow into a pavement through each of the different pavement layers. This rate of penetration in mm/blow (the DN value) is a function of the in situ shear strength of the material at the in situ moisture content and density of the pavement layers at the time of DCP testing.

### 5.4.3 Layer-strength diagram

The profile in depth of the pavement gives an indication of the in situ properties of the materials in all the pavement layers up to the depth of penetration of 800 mm. A schematic of the DCP is shown in Figure 5-1 while a typical DCP in situ strength profile (layer-strength diagram) is shown in Figure 5-2.

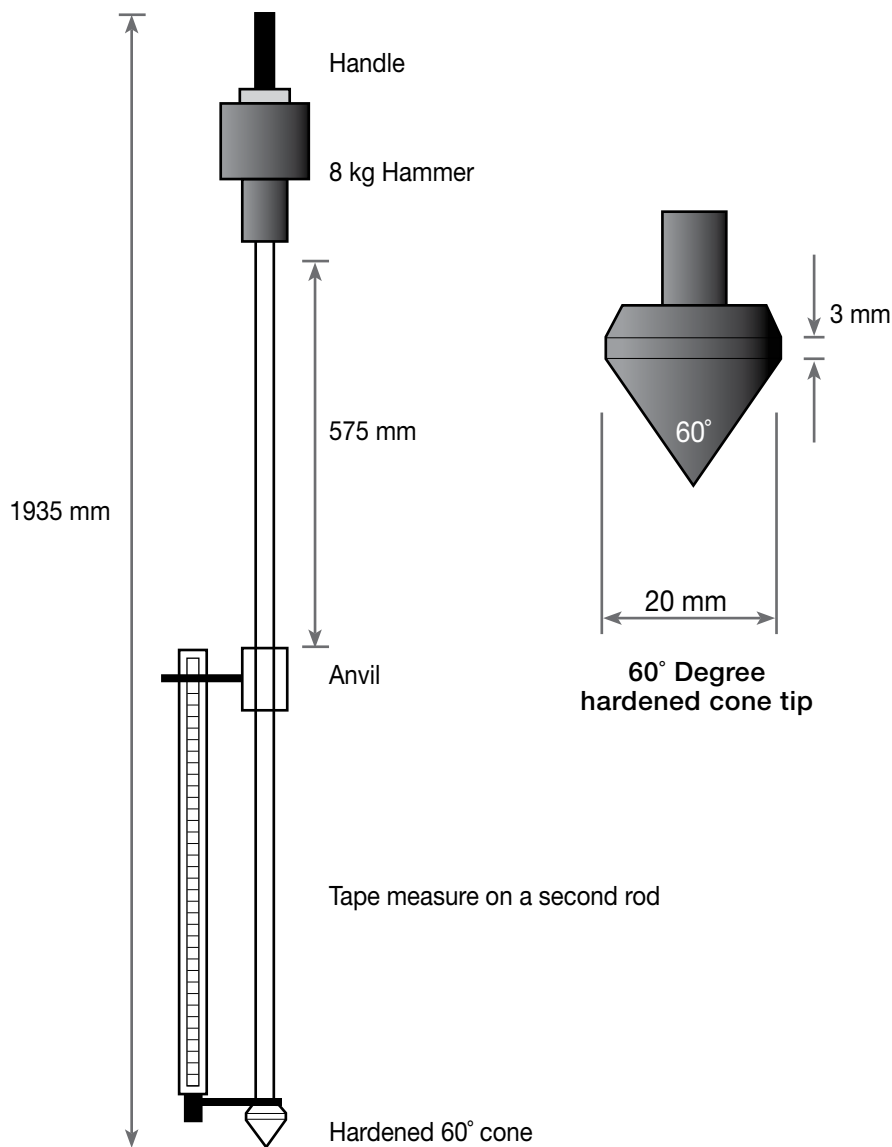

Figure 5-1: The DCP

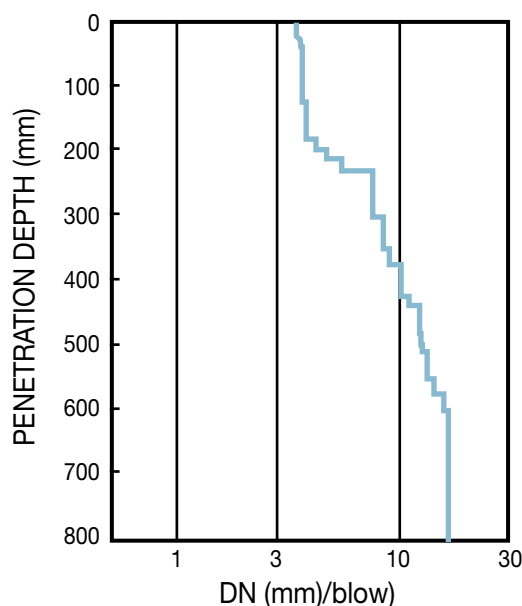

Figure 5-2: Layer-strength diagram

#### 5.4.3 DCP structure number

The DCP structure number is the number of DCP blows required to penetrate a pavement structure or layer. For example, the DSN800, a parameter which allows the bearing capacity of different pavements to be compared, is the number of blows required to penetrate the pavement to a depth of 800 mm.

#### 5.4.4 Pavement strength balance

The DCP design and analysis method is based strongly on the concept of *pavement strength balance* in which the strength balance of a pavement structure is defined as the change in the strength of the pavement layer with depth. A well balanced pavement structure is one in which the strength of the pavement layers and their composite bearing capacity decrease progressively and smoothly with depth from the surface without any discontinuities.

From a knowledge of the DN values of various pavement layers, those of relatively high and relatively low strength can be distinguished from each other and the balance of the pavement at any depth can be evaluated. This has led to the development of a pavement classification system in which shallow, deep and inverted pavements can be distinguished from each other and further differentiated in terms of whether they are well-balanced, averagely balanced or poorly balanced.

The more the final bearing capacity is derived from the upper pavement layers (base and subbase) *relative* to the lower layers, the “shallower” the pavement structure. In contrast, the more the lower layers (subgrade) contribute to the final bearing capacity *relative* to the upper layers, the “deeper” the pavement structure.

Standard pavement balance curves and the classification of the pavement structure derived from the DCP measurements are presented as part of the output of the DCP analysis programme and the designer does not have to manually determine this information. Nonetheless, the underlying concepts behind the manner of determining Standard Pavement Balance Curves (SPBC) and classifying pavements on the basis of their balance is presented as background information in Annex 5A.

### 5.4.5 Relationship between DN and CBR

The DCP rate of penetration into gravel or soil material (i.e. the DN value in mm/blow) is a reasonably good predictor of CBR (and UCS) at the prevailing in situ moisture and density conditions using the Kleyn relationship  $CBR = 410 \times DN^{-1.27}$  which is applicable to low traffic roads with DN values  $> 2$  mm/blow.

The relationship between the DN value and both CBR and UCS is illustrated in Figure 5-3. It must be stressed that the CBR values were determined using the South African TMH 1 testing standards for which the procedure for CBR determination differs significantly from the British Standards (BS). Thus, the DN-CBR correlation based on the BS method of CBR determination would be quite different to the one based on the TMH 1 method.

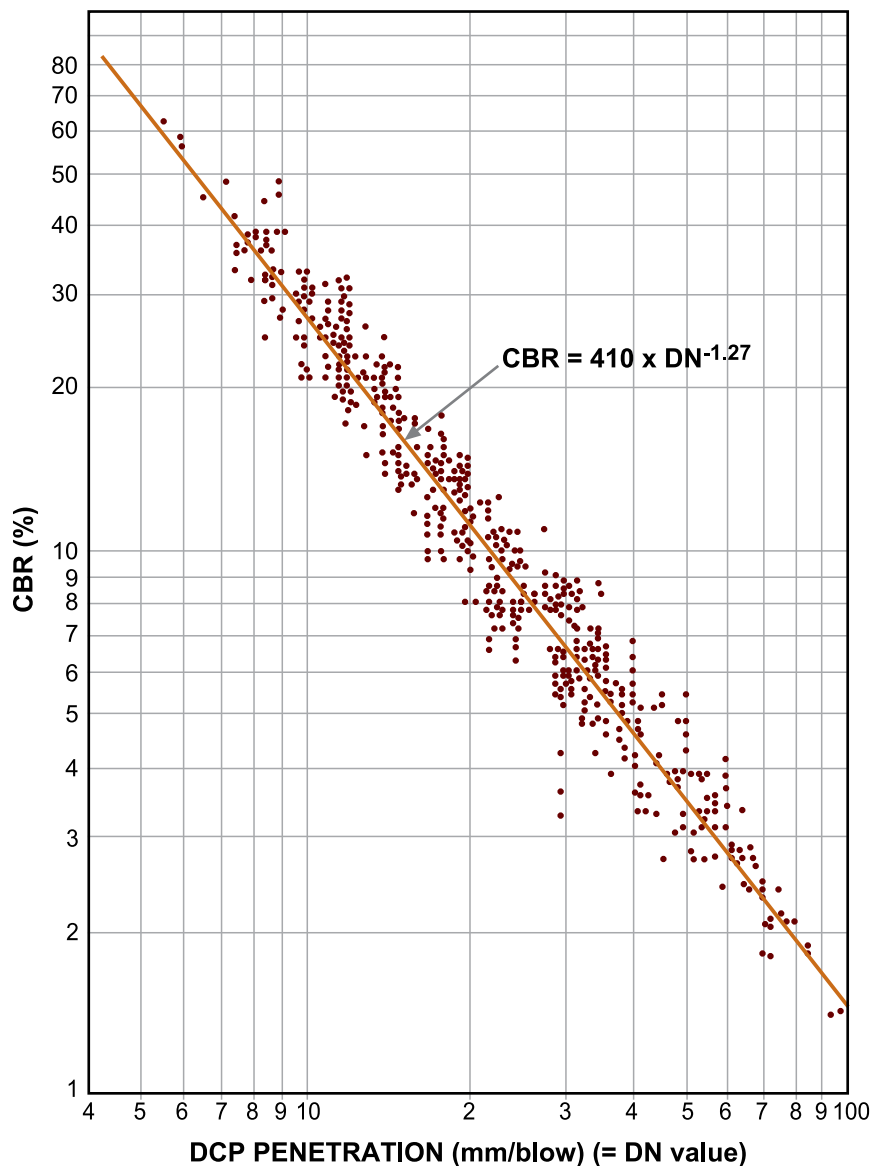

Figure 5-3: Relationship between DN and CBR

As illustrated in Figure 5-3, there is a fair amount of scatter in the DCP-CBR plot. This is due not only to the inherent variability exhibited by natural gravels but also to the very poor reproducibility of the CBR test. It is for this important reason that the evaluation of the imported material for use in the pavement layer(s) is based on a laboratory DN value rather than a laboratory CBR value as presented in Chapter 6.

## 5.5 DCP Design Procedure

### 5.5.1 Flow diagram

A flow diagram of the DCP design process is shown in Figure 5-3 and is self-explanatory. The process entails carrying out two parallel streams of activity aimed ultimately at determining a suitable pavement structure from a design catalogue and comparing that with the existing pavement structure determined from the DCP survey.

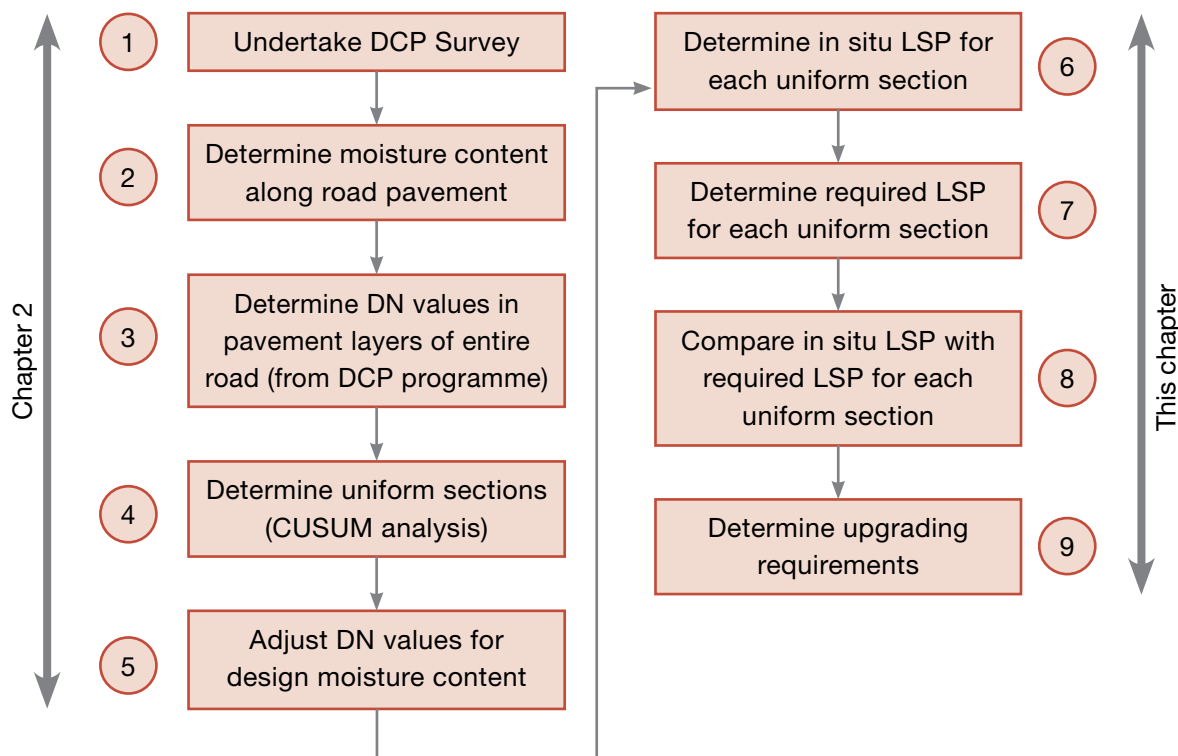

Figure 5-4: Flow diagram of DCP design procedure

The manner of undertaking Steps 1 to 5 has been described previously in Chapter 2. In Section 2.5.5, the expected, long-term, in-service moisture conditions in the new sealed road were considered in relation to the moisture conditions prevailing when the DCP survey was carried out on. On this basis the DN value for each layer in each uniform section to be used for design is based on the 20th, 50th or 80th percentile as indicated in Table 2-2.

The manner of carrying out the remaining Steps 6 to 9 of the DCP design procedure is described below.

#### 5.5.2 Step 6: Determine in situ layer strength profile for each uniform section

This determination is best undertaken using the DCP program. Input into the program the DN values obtained from Step 5 and, based on an average analysis for each uniform section as undertaken by the program, the layer strength (DN) profiles for each uniform section are plotted as shown in Figures 5.5 and Figure 5.6 and the percentiles to be used in the design process are computed automatically.

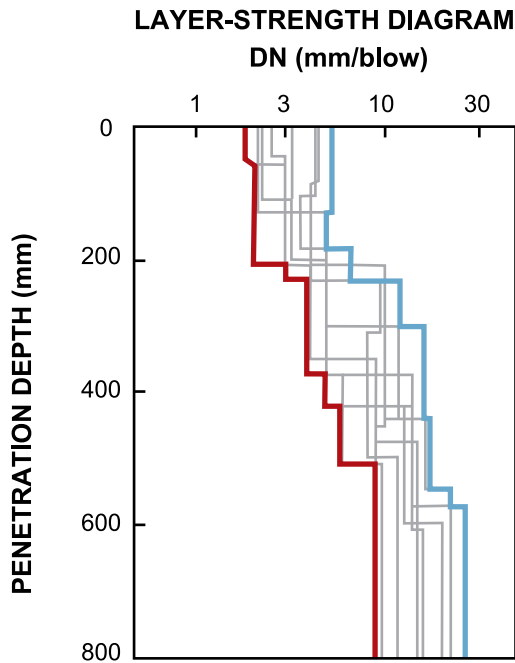

Figure 5-5: Collective DCP strength profile

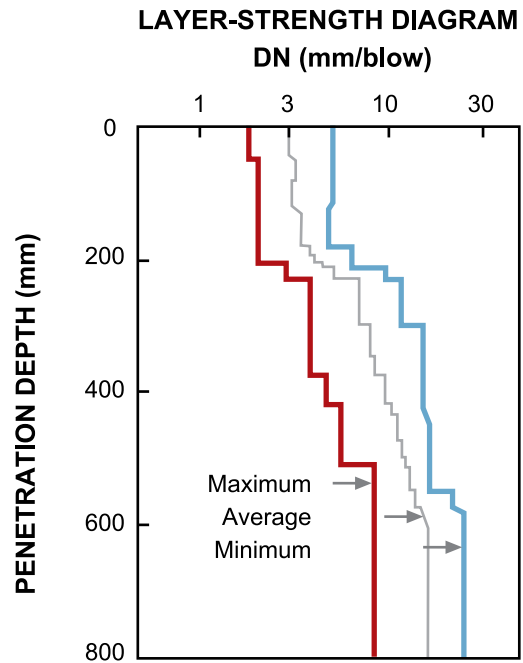

Figure 5-6: Average and extreme DCP strength profiles

**5.5.3 Step 7: Determine the required layer strength profile for each uniform section**

For a particular design traffic class (see Chapter 3), the required layer strength profile for each uniform section is determined from the DCP design catalogue which is presented in Table 5-1 and illustrated in Figure 5-7 for different traffic categories. These have been derived from back-analysis of a number of LVSRs in the region, including Malawi.

The design catalogue is based on the anticipated, long term, in-service moisture condition. If there is a risk of prolonged moisture ingress into the road pavement then the pavement design should be based on the soaked condition.

Table 5-1: DCP-DN design catalogue for different traffic classes

Traffic Class E80 x 10 <sup>6</sup>	LE 0.01 0.003 - 0.010	LE 0.03 0.010 - 0.030	LE 0.1 0.030 - 0.100	LE 0.3 0.100 - 0.300	LE 0.7 0.300 - 0.700	LE 1.0 0.700 - 1.0
0- 150 mm Base ≥ 98% Mod. AASHTO	DN ≤ 8	DN ≤ 5.9	DN ≤ 4	DN ≤ 3.2	DN ≤ 2.6	DN ≤ 2.5
150-300 mm Subbase ≥ 95% Mod. AASHTO	DN ≤ 19	DN ≤ 14	DN ≤ 9	DN ≤ 6	DN ≤ 4.6	DN ≤ 4.0
300-450 mm subgrade ≥ 95% Mod. AASHTO	DN ≤ 33	DN ≤ 25	DN ≤ 19	DN ≤ 12	DN ≤ 8	DN ≤ 6
450-600 mm In situ material	DN ≤ 40	DN ≤ 33	DN ≤ 25	DN ≤ 19	DN ≤ 14	DN ≤ 13
600-800 mm In situ material	DN ≤ 50	DN ≤ 40	DN ≤ 39	DN ≤ 25	DN ≤ 24	DN ≤ 23
DSN 800 (blows)	≥ 39	≥ 52	≥ 73	≥ 100	≥ 128	≥ 143

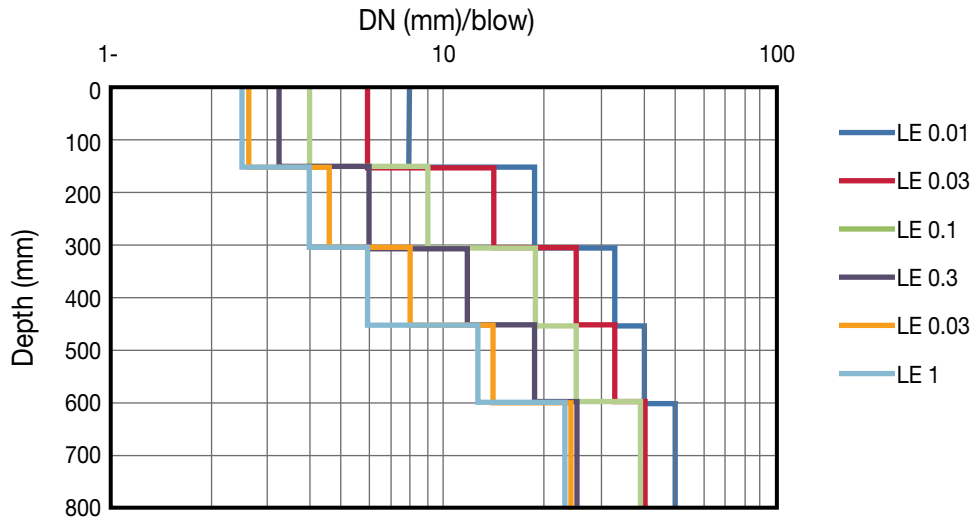

Figure 5-7: Layer Strength Diagram for various traffic classes

**5.5.4 STEP 8: Compare representative in situ strength profiles with the required strength profile**

Plot the required strength profile on the same layer-strength diagram on which the uniform section layer strength profiles were plotted as illustrated in Figure 5-8. The comparison between the in situ strength profile with the required design strength profile allows the adequacy of the various pavement layers in depth to be assessed for carrying the expected future traffic loading. Points lying to the right of the required strength profile for a specific traffic category indicate material of inadequate strength at that depth.

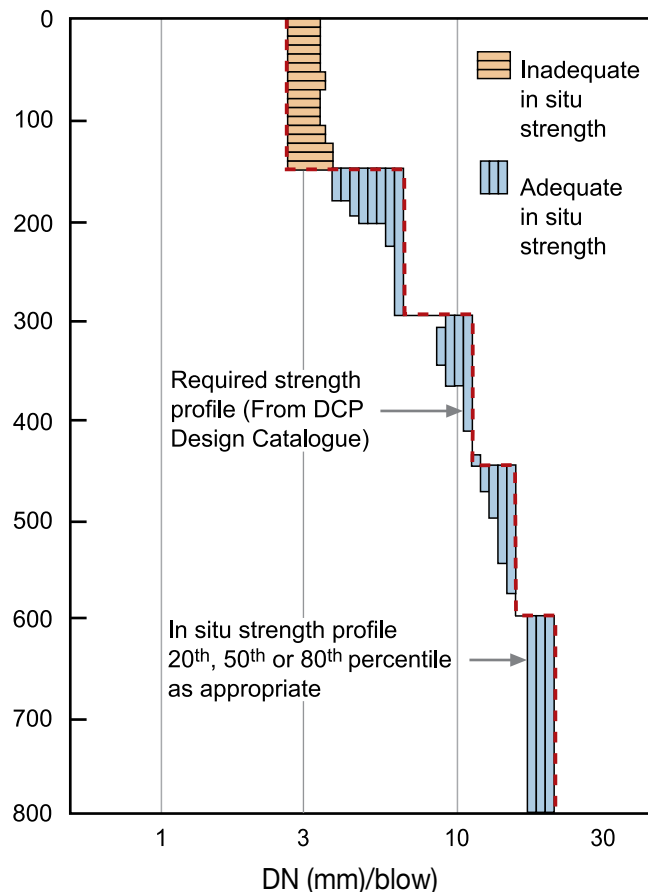

Figure 5-8: Comparison of DCP design and in situ strength profiles

### 5.5.5 STEP 9: Determine the upgrading requirements

**Option 1:** If the in situ strength profile of the existing gravel road complies with the required strength profile indicated by the DCP catalogue for the particular traffic class, the road would need to be only re-shaped, compacted and surfaced (assuming that the drainage requirements are adequate).

**Option 2:** If the in situ strength profile of the existing gravel road does not comply with the required strength profile indicated by the DCP catalogue for the particular traffic class, then the upper pavement layer(s) would need to be:

- **Reworked** - if only the density is inadequate and the required DN value can be obtained at the specified construction density and anticipated in-service moisture content
- **Replaced** – if the material quality (DN value at the specified construction density and anticipated in-service moisture content) is inadequate, then appropriate quality material will need to be imported to serve as the new upper pavement layer(s)
- **Augmented** – if the material quality (DN value) is adequate but the layer thickness is inadequate, then imported material of appropriate quality will need to be imported to make up the required thickness prior to compaction

## 5.6 Strengths and Limitations of the DCP Design Method

### 5.6.1 Strengths

The main strengths of the DCP method are as follows:

- Relatively low cost, robust apparatus that is quick and simple to use allowing comprehensive characterisation of the in situ road conditions
- Provides improved precision limits compared to the CBR test
- Very little damage is done to the pavement being tested (effectively non-destructive) and very useful information is obtained
- The pavement is tested in the condition at which it performs and the test can be carried out in an identical manner both in the field and in the laboratory
- The simplicity of test allows repeated testing to minimise errors and also to account for temporal effects
- The laboratory DN value is determined over a depth of 150 mm and not just the top 25 – 50 mm as with the CBR test
- The method is as good or better than any other method in taking into account variations in moisture content and provides data quickly for analysis

Whilst not necessarily a strength, the DCP method of design provides a number of aspects of in-built conservatism as follows:

- (a) The DCP survey would probably record a conservative DN value in the gravel wearing course as, when incorporated in the new pavement structure, typically as the new subbase, compaction to refusal of this layer would most likely result in a higher density/lower DN value compared with that obtained during the original DCP survey. Underlying layers should also be improved slightly during compaction of overlying materials.
- (b) Improved drainage, which should be a mandatory requirement when upgrading a gravel road to a paved standard, would invariably reduce in-service moisture conditions along the section affected and, by so doing, lower DN values.
- (c) For well balanced pavements, if the traditionally recommended load equivalent exponent of 4 to 4.2 is used, this could over-estimate the design traffic loading which would result in the need for a thicker pavement than required.

### 5.6.2 Limitations

The main limitations that are likely to affect the results and their interpretation and that need to be considered when using the DCP design method include:

- Use in very coarse granular or lightly stabilised materials
- Very hard cemented layers in the pavement structure
- The possibility of not recording very weak or thin layers when taking depth measurements every 5 blows
- Poorly executed tests (hammer not falling the full distance, non-vertical DCP, excessive movement of the depth measuring rod, etc.)
- Changes to standard specifications and the associated bidding documents
- As with all empirical methods, use outside the type of environment (materials, climate, traffic, etc.) in which it was developed

Many of the above limitations are controllable if taken into account when using the DCP. Ultimately, the onus remains on the designer to understand the environment and implications of each test in relation to the in situ state of the material. This includes aspects such as material composition, presence of large stones or hard layers, moisture content, density, etc. Sound engineering judgment and understanding as well as knowledge of the specific site are necessary to maximise the information that can be obtained from a DCP profile. Thus, unless the field conditions are fully comprehended, the design engineer may draw erroneous conclusions or wrongly extrapolate data provided from site teams.

## ANNEX 5A: Determination of Strength-Balance of Pavements

### Pavement strength balance concepts

The pavement balance at any depth can be determined from the following formula:

$$DSN(\%) = D[400B + (100 - B)^2] / [4BD + (100 - B)^2]$$

Where: DSN = pavement structure number (%)

B = parameter defining the standard pavement balance curve (SPBC)

D = pavement depth (%)

The above formula allows a series of curves to be developed for different pavement structure numbers and depths. These can be plotted as Standard Pavement Balance Curves (SPBC) as shown in Figure 5A-1.

### STANDARD PAVEMENT BALANCE CURVES (SPBC) (-90 ≤ B < +90)

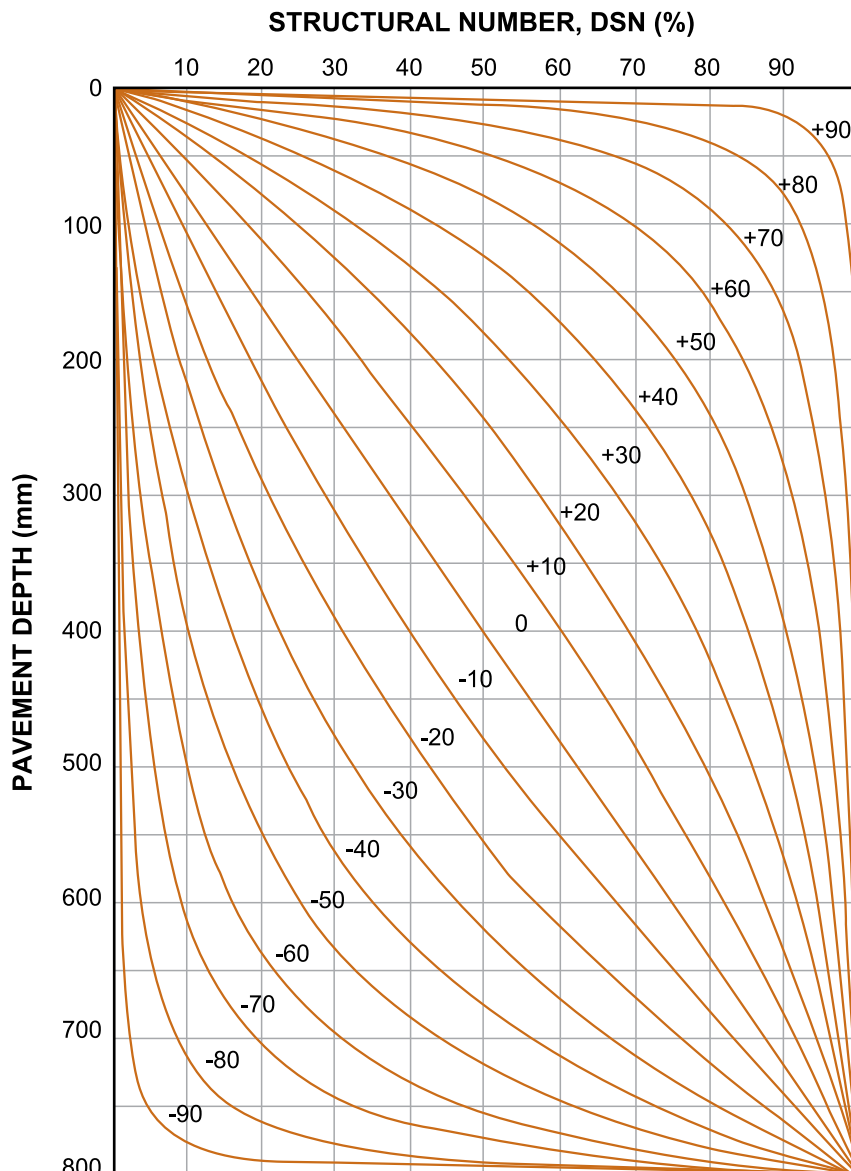

Figure 5A-1: Standard Pavement Balance Curves

The number of DCP blows required to reach a certain depth, expressed as a percentage of the number of DCP blows needed to penetrate the pavement to a depth of 800 mm, is defined as the Balance Number (BN) at that depth as illustrated in Figure 5A-2. For example, the BN100 in the Figure is the number of blows as a percentage of the DSN800 required to penetrate to a depth of 100 mm, i.e. 40 at 12.5% ( $100/800 = 12.5\%$ ).

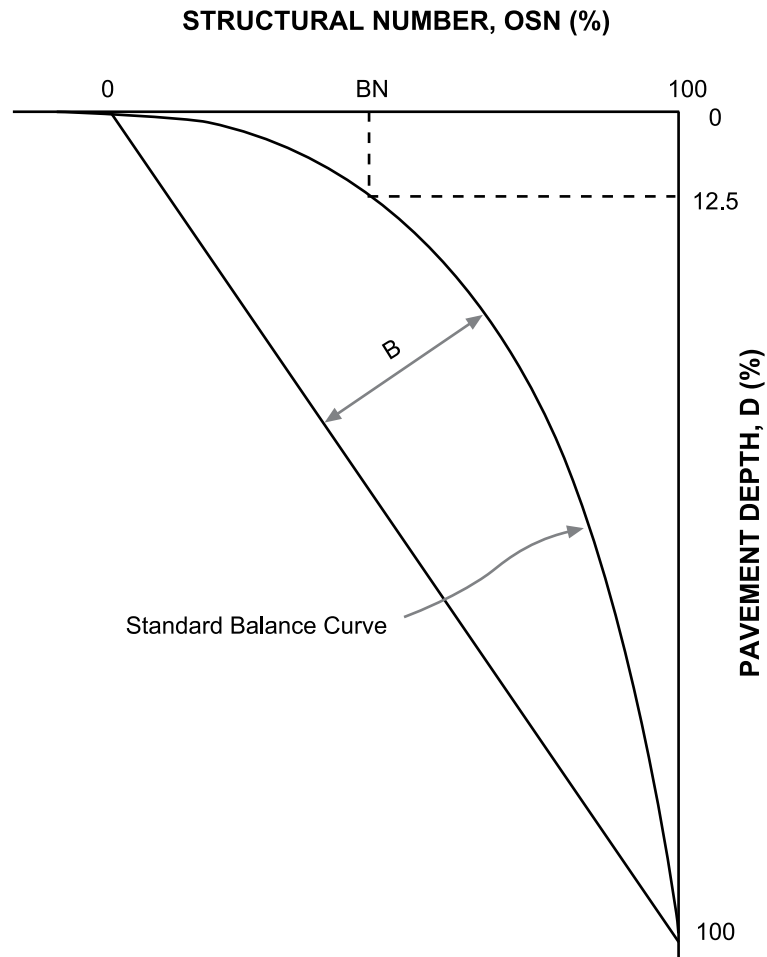
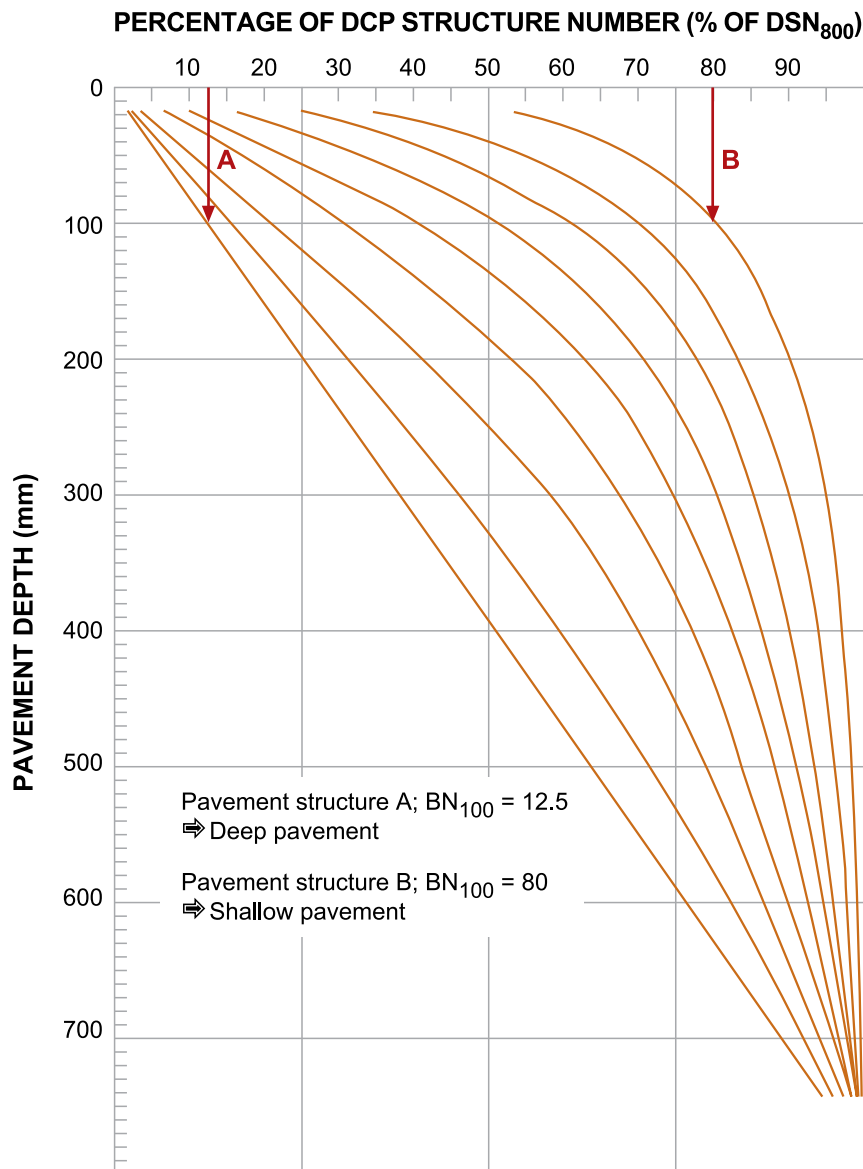

Figure 5A-2: Graphic representation of the formula for the Standard Pavement Balance Curve (SPBC)

Figure 5A-3 shows pavement strength-balance curves for typical natural gravel and lightly cemented pavements in the Southern African region.



**Figure 5A-3: Shows pavement strength-balance curves for typical natural gravel and lightly cemented pavements in the Southern African region.**

The higher the  $BN_{100}$  value (those tending to 80), the greater is the contribution to overall strength from the upper pavement layers. Such pavements are considered to be “shallow” and tend to be composed of one or two thin, strong and relatively stiff upper layer(s) with rapidly diminishing support at depth from the underlying material. In contrast, the lower the  $BN_{100}$  value the greater the contribution to overall strength from the lower pavement layers. Such pavements are considered to be “deep” and tend to be composed of a number of relatively less rigid layers of relatively equal strength, affording generous support at depth.

A relationship between the  $BN_{100}$  value and the power exponent “n” used to calculate the load equivalency factor has also found that shallower pavements are more susceptible to overloading (i.e. they exhibit a higher “n” exponent) than deep pavements.

### Pavement classification

The pavement strength balance curves have been used to develop a pavement classification system in which any pavement is classified in terms of the Balance Curve (B) which is the balance curve of the pavement and the deviation (A) between the SPBC and the measured balance curve which represents a “goodness of fit” parameter for the pavement. This deviation from a SPBC represents the state of imbalance in the structure.

By way of example, Figure 5A-4 illustrates a balanced pavement structure while Figure 5A-5 illustrates an unbalanced structure in which the imbalance is indicated by the deviation of the pavement balance curve from the SPBC.

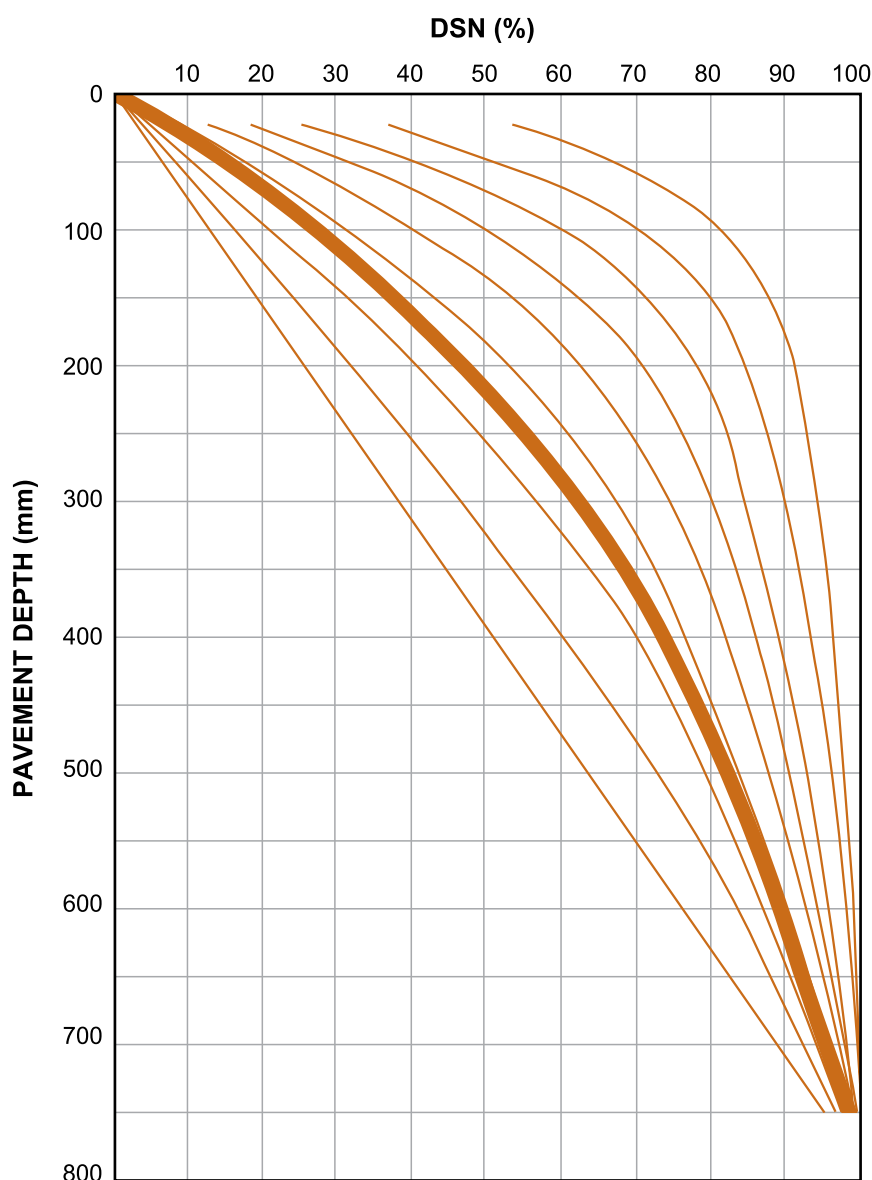

Figure 5A-4: Balanced structure

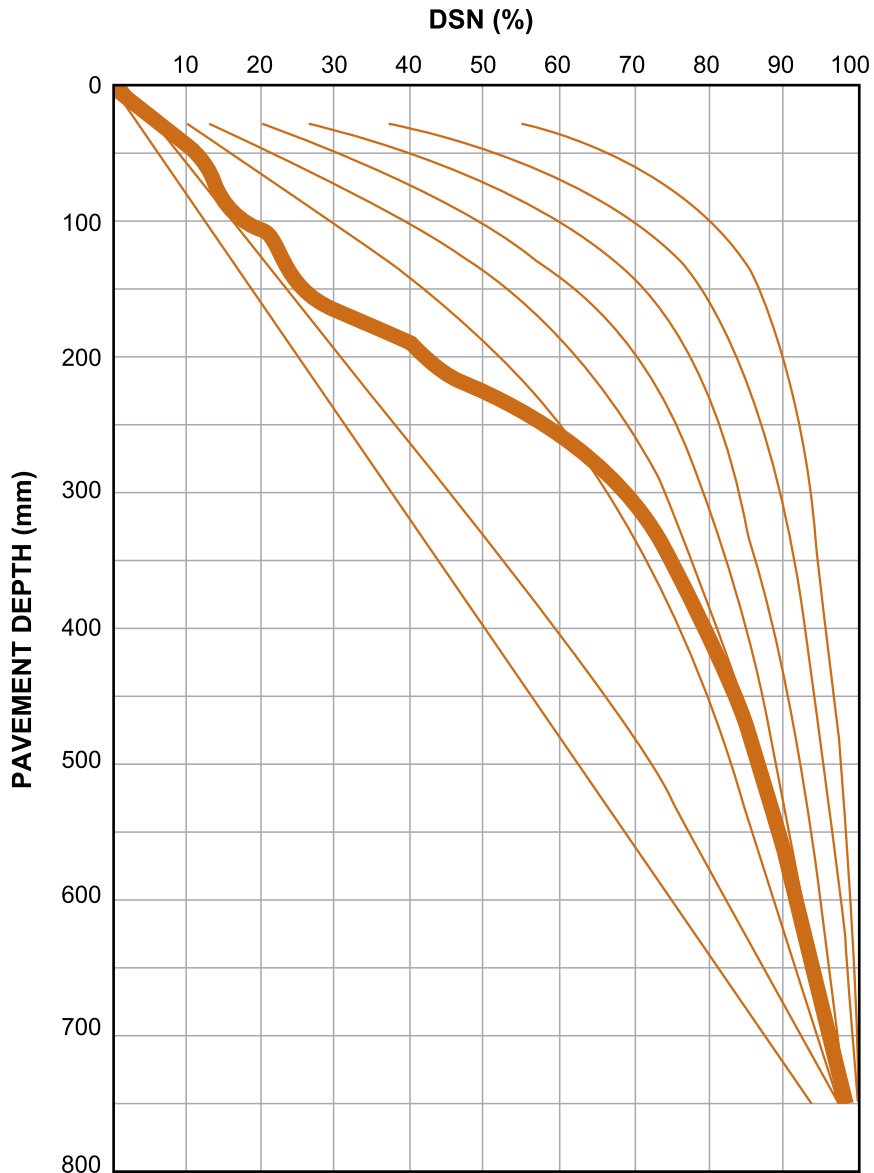

Figure 5A-5: Unbalanced structure

The A and B parameter limits for defining the different categories in the pavement classification system are summarised below:

Shallow pavements	$B \geq 40$ (BN $\geq 42\%$ )
Deep pavements	$0 \leq B < 40$ ( $12.5\% \leq \text{BN} < 42\%$ )
Inverted pavements	$B < 0$ (BN $< 12.5\%$ )
Well balanced	$0 \leq A \leq 1200$
Averagely balanced	$1200 < A \leq 3000$
Poorly balanced	$A > 3000$

Each cell in the classification system is defined by an A and a B descriptor, resulting in a possible 9 classification categories.

## 6. MATERIALS

### 6.1 Introduction

Naturally occurring soils, gravel soil mixtures and gravels occur extensively in many parts of Malawi. These unprocessed materials are a valuable resource as they are relatively cheap to exploit compared, for example, to processed materials such as crushed rock, and are often the only source of material within a reasonable haul distance of the road alignment. Thus, in order to minimise construction costs, maximum use must be made of locally available materials. However, their use requires not only a sound knowledge of their properties and behaviour but also of the traffic loading, physical environment and their interactions.

Although many naturally occurring materials do not meet conventional selection criteria they, nonetheless, still provide satisfactory performance. Their choice must therefore be based on locally developed selection criteria, non-standard testing, and attention to construction technique. In addition, it is important to recognise that the specifications for materials must be coupled to the pavement design method being used - in this case, the DCP design method.

### 6.2 Purpose and Scope

The purpose of this chapter is to provide guidance on the selection and use of locally available materials in the construction of LVSRs. The topics covered include:

- Approach to using local materials
- Selection of materials
- Specification of materials
- Testing of materials

### 6.3 Approach to Using Local Materials

In order to optimise the use of naturally occurring materials, a holistic approach is required in which attention is paid to the compatibility between the pavement structure, the materials used, the type of surfacing, construction processes and, above all, control of moisture through effective drainage. Moreover, where some degree of risk in long-term performance can be accepted, then strict requirements may be relaxed and a wide range of naturally occurring non-standard materials may successfully be used. However, such use demands careful attention to three factors:

- basic engineering principles; there must be a careful evaluation of the in-service environment and a reasonable assurance that adequate internal and external drainage will be provided (see Chapter 8)
- compacted density; there must be very good construction quality control (see Section 6.4 (2))
- probability of failure; there must be a realistic acceptance of the higher risk of lesser performance

A fundamental feature of the DCP design method is that it utilises the existing road structure without disturbing its inherent strength derived from consolidation by traffic over many years and requires the addition of a minimum thickness base (sometimes subbase) layer of appropriate quality. Such quality is expressed in terms of the materials DCP resistance to penetration, i.e. its DN value, at the specified compaction density and expected in service moisture condition – ***the parameter that serves as the criterion for selecting the materials to be used in the upper/base layer of the LVSR pavement.***

The DCP design approach and related method of materials selection differ markedly from the more traditional design approaches. In these latter approaches, pavement materials are traditionally evaluated by classification tests, such as grading and plasticity. However, research and investigations from the region and internationally have led to replacing these criteria with tests and specifications based on the measurement of the required engineering properties of strength and stiffness. More specifically, it has been shown that **provided the design DN value is achieved** - essentially a measure of a material's shear resistance to penetration at a given moisture and density - then in-service performance indirectly takes account of the actual grading and plasticity of the material which do not need to be separately specified for LVSRs. Thus, a poorly graded, highly plastic material would not be expected to provide a relatively low DN value (high resistance to penetration) that might be specified for the base layer of a LVSR.

## 6.4 Selection of Materials

The materials selected for use in the upper layers of a LVSR should exhibit the following attributes at the specified density and anticipated in-service moisture content:

- adequate bearing capacity under any individual applied load
- adequate bearing capacity to resist progressive failure under repeated individual loads
- the ability to retain bearing capacity under various environmental influences such as climate, drainage and moisture regime

As discussed in Section 6.3, the criterion to be used for selecting a material for use in a LVSR should be based primarily on its strength as measured by resistance to penetration, or DN value. A proper evaluation of the suitability of the materials for incorporation in the pavement will require a knowledge of the DN/moisture/density relationship as discussed below.

- (1) **Strength** – The required strength of the material is determined in terms of a laboratory DCP DN value at a specified moisture and density. The procedure for obtaining the laboratory DN value of the material is presented in Annex 6A.

Table 6-1 provides an approximate guide to the relationship between the laboratory CBR and DN values at varying moisture contents.

**Table 6-1: Approximate relationship between laboratory CBR and DN values at varying moisture contents**

Material Classification	CBR and DN values at moisture content					
	Soaked		OMC		0.75 OMC	
	CBR	DN	CBR	DN	CBR	DN
NG80 <sup>1</sup>	80	3.7	95	3.2	150	2.2
NG65 <sup>1</sup>	65	4.5	90	3.8	145	2.5
NG45 <sup>2</sup>	45	5.7	70	4.2	110	3.0
NG30 <sup>2</sup>	30	8.0	60	4.7	95	3.2
NG25 <sup>2</sup>	25	9.1	55	5.0	85	3.5
NG15 <sup>3</sup>	15	14.0	50	5.4	80	3.6
NG10 <sup>3</sup>	10	19.0	35	7.0	60	4.6

1 - @ 98% MAASHO; 2 - @ 95% MAASHO; 3 - @ 93% MAASHO.

- (2) **The strength/density/moisture relationship:** The moisture and density dependence of the materials to be used in the imported upper/base layers of the new road must be evaluated carefully so that a full understanding is obtained of the potential performance of the material under the possible moisture conditions which may occur in service.

Achievement of the above will require that a normal borrow pit investigation is carried out with representative samples being obtained for laboratory testing to determine the DN value at varying moisture contents and densities.

Figure 6-1 shows a typical relationship between DN, density and moisture content for a naturally occurring material in Malawi which illustrates two critical factors that crucially affect the long-term performance of the road:

- 1) The need to specify the highest level of density practicable (so-called “compaction to refusal” by employing the heaviest rollers available).
- 2) The need to ensure that the moisture content in the outer wheel track of the road does not rise above OMC. This will require careful attention to drainage, as discussed in Chapter 7.

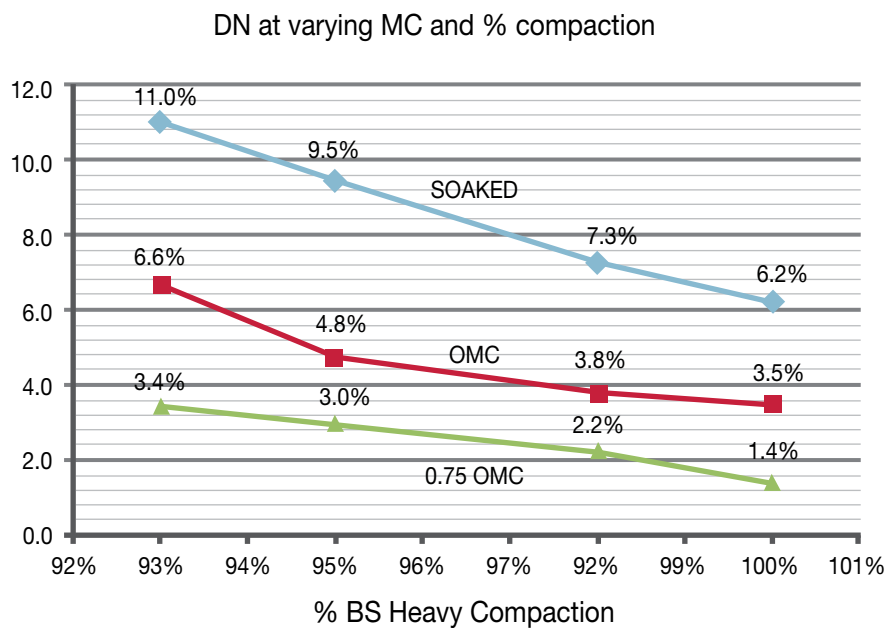

**Figure 6-1: DN/density/moisture relationship**

- (3) **Grading modulus (GM):** This parameter is expressed by the relationship:  

$$GM = [300 - (P_2 + P_{425} + P_{075})] / 100$$
 where  $P_2$ , etc., denote the percentage passing through that sieve size. Its inclusion as a specification criterion is to avoid the unnecessary testing of materials that are patently unsuitable for use in a pavement layers in terms their grading and/or plasticity, e.g. very fine, plastic soils or very coarsely/poorly graded gravels.

## 6.5 Specification of Materials

The two material's parameters that need to be specified for the imported pavement layers are as follows:

- (a) **Density:** The density to which the material in the upper/base layer must be compacted should be the highest that is practicable, i.e. "compaction to refusal".
- (b) **DN value:** The DN value of the materials to be used in the upper/base layer of the pavement at a specified density and moisture content. These values will be determined as an output of the DCP design method.
- (c) **Grading modulus:** The minimum GM (typically > 1.0) and maximum GM (typically < 2.25) of the material as a prerequisite for subsequent laboratory testing.

## 6.6 Testing of Materials

Materials testing is normally prescribed in standards put out by various countries, of which the BS (British), ASTM (American) and TMH (South Africa), are in common use in the region. Unfortunately, these methods differ in many respects with regard to the actual test procedure and the method of testing. For example, authorities employing a BS LL device will obtain a Plasticity Index (PI) on average 4 units higher than those using an ASTM LL device. It is important, therefore, not to indiscriminately mix testing standards because the differences in test procedure produce quite different results leading to inconsistencies in the quality of materials incorporated in the road works.

## ANNEX 6A: Determination of Laboratory DN Value

The procedure to be followed in determining the DN value of a material is similar to that for the more traditional CBR test except that a DCP is used to penetrate the CBR mould instead of the CBR plunger.

### 1. Collection of samples

Potential borrow pits shall be surveyed by trial pit excavation and sampling at the detailed design stage. The survey shall provide sufficient quantities for all pavement layers and the sampling frequency shall be the minimum indicated in Table 6A-1 per DN test.

Table 6A-1: Minimum test frequency

Intended Use	Required volume (m <sup>3</sup> )/ DN test
Base course	5 000 m <sup>3</sup>
Subbase	10 000 m <sup>3</sup>
Improved subgrade	10 000 m <sup>3</sup>
Fill	20 000 m <sup>3</sup>

### 2. Preparation of samples

The manner of dealing with oversize in the sample preparation for DN testing should be in accordance with the SANS 3001 Procedure 2 (crushing method) which may be summarised as follows:

- Screen field sample on 20 mm sieve
- Remove material retained on 20 mm sieve and crush so that all material passes 20 mm sieve
- Recombine crushed material with rest of field material and mix thoroughly
- Take care not to over-crush material
- Use minimum effort to reduce material so that it passes the 20 mm sieve

### 3. Compaction of samples

Some natural, particularly pedogenic, gravels (e.g. laterite, calcrete) exhibit a self-cementing property in service, i.e. they gain strength with time after compaction. This effect must be evaluated as part of the test procedure by allowing the samples to cure prior to testing in the manner prescribed below.

- (a) Thoroughly mix and split each borrow pit sample into nine sub-samples for DN testing in a CBR mould at three moisture contents: (a) soaked, (b) at OMC and (c) at 0.75 OMC and three compactive efforts: (a) BS Light, (b) BS Intermediate and (c) BS Heavy as summarised below:

Compactive effort	Moisture content		
	Soaked	OMC	0.75 OMC
BS Light	Soaked	OMC	0.75 OMC
BS Intermediate	Soaked	OMC	0.75 OMC
BS Heavy	Soaked	OMC	0.75 OMC

- (b) The samples should be allowed to equilibrate for the periods shown below before DN testing is carried out to dissipate compaction stresses and to allow the samples to cure.
- (a) **4 days soaked:** After compaction, soak for 4 days, allow to drain for at least 15 minutes, then undertake a DCP test in the CBR mould to determine the soaked DN value.
- (b) **At OMC:** After compaction, seal in a plastic bag and allow to “cure” for 7 days (relatively plastic, especially pedogenic, materials (PI > 6), or for 4 days (relatively non-plastic materials (PI < 6)), then undertake a DCP test in the CBR mould to determine the DN value at OMC. (N.B: The curing period is required to dissipate pore pressure generated during the compaction process).
- (c) **At 0.75 OMC:** Air dry the sample in the sun (pedogenic materials) or place the sample in the oven to maximum 50 degrees Celsius (non-pedogenic materials) to remove moisture. Check from time to time to determine when sufficient moisture has been dried out to produce a sample moisture content of about 0.75 OMC (it doesn't have to be exactly 0.75 OMC, but as close as possible). Once this moisture content is reached, seal the sample in a plastic bag and allow to cure for 7 days (pedogenic materials) or for 4 days (non-pedogenic materials) to allow moisture equilibration before undertaking the DCP test at approximately 0.75 OMC. Weigh again before DCP testing to determine the exact moisture content at which the DN value was determined.

#### 4. Determination of DN value

Each of the nine specimens should be subjected to DCP testing in the CBR mould as summarised below and illustrated in Figure 6A-1.

- (a) Secure the CBR mould to the base plate and compact sample in standard CBR as indicated in Section 1.1 above.
- (b) Place the full mould on a level floor and place the annular weight on top of the mould.
- (c) Place an empty CBR mould upside down next to the full mould as shown. Alternatively use bricks or cement blocks to provide a steady platform for the base of the DCP ruler level with or slightly higher than the top of the full mould.
- (d) Position the tip of the DCP cone in the middle of the CBR mould, hold the DCP in a vertical position, knock it down carefully until the top of the 3 mm shoulder is level with the top of the sample and record the zero reading.
- (e) Knock the cone into the sample with “n” number of blows and record the reading on the ruler after every “n” blows as shown in the example. At OMC and 0.75 OMC “n” may be 5. At 4-days soak “n” may be 1 or 2. “n” does not have to be the same number for all readings.

- (f) Continue until just before the tip of the cone touches the base plate and stop there in order not to blunt the cone (the last reading minus the “zero blows” reading must be less than the height of the mould 115 mm).
- (g) Determine the weighted average DN value (see example below).

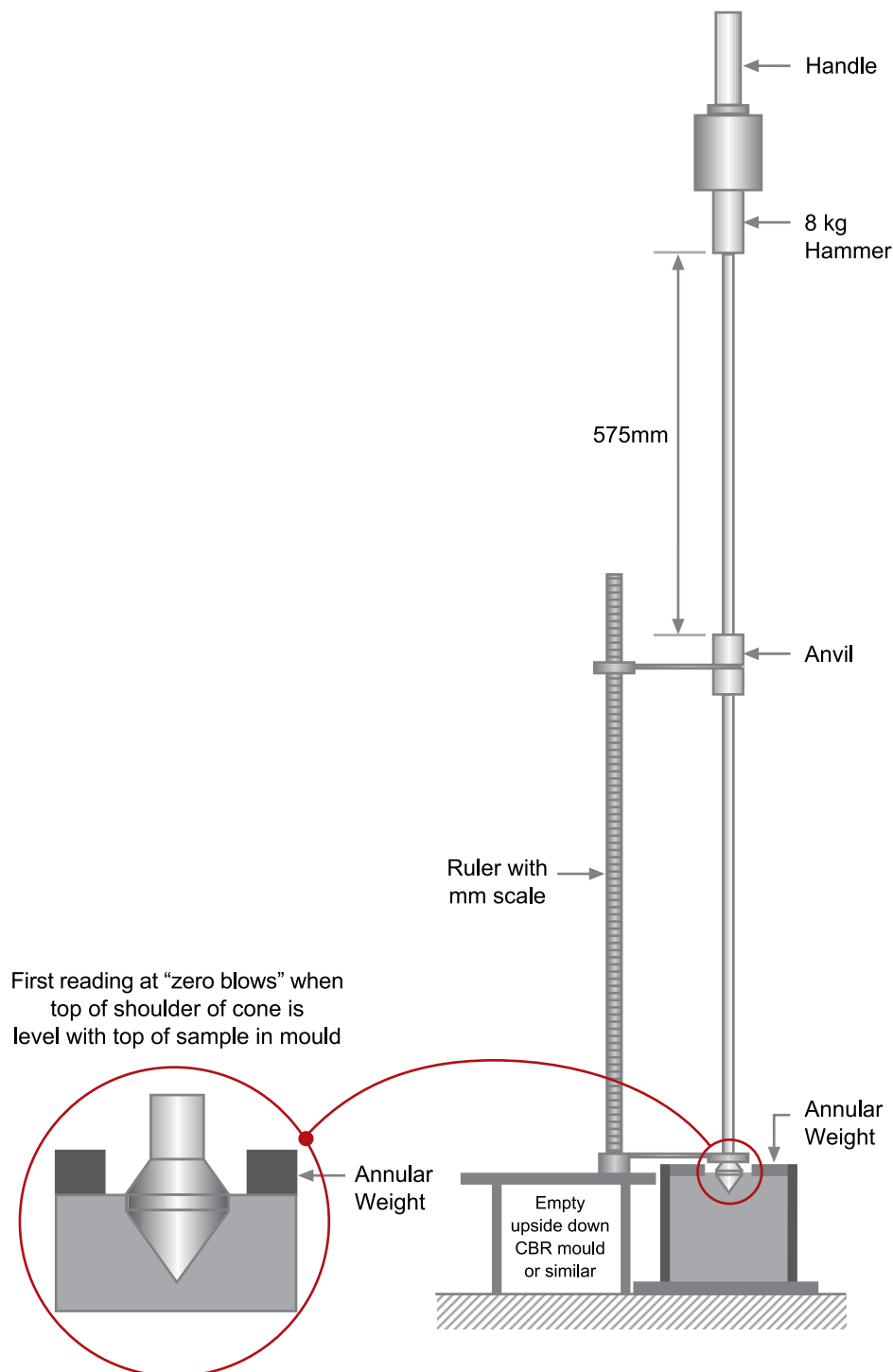

Figure 6A-1: Determination of laboratory DN value (Not to scale)

### 5. Procedure for calculating weighted average DN value for DCP lab test:

- Record the readings as shown and calculate the DN per “n” blows and Average DN per blow.
- Calculate the Weighted Average DN for the whole test using the formula:

$$\text{DN} = \frac{\sum(\text{Avg DN per blow} \times \text{DN per } n \text{ blows})}{\text{Penetration depth}}$$

Note that the Weighted Average DN is different from the Average DN which is not representative for the sample and is only to illustrate the difference.

- Carry out at least 2 more tests on the same material and calculate the average DN for the three (or more) tests.
- Assess whether the material satisfies the design criteria from the DCP Design Catalogue.

**Table 6A-1: Determination of lab DN values at varying moisture contents and specific density**

4 Days Soaked				OMC				0.75 OMC			
98% BS Heavy				98% BS Heavy				98% BS Heavy			
No of blows n (n)	DCP Reading (mm)	DN per n blows (mm/blow)	Avg. DN per blow (mm/blow)	No of blows (n)	DCP Reading (mm)	DN per n blows	Avg. DN per blow	No of blows n (n)	DCP Reading (mm)	DN per n blows (mm/blow)	Avg. DN per blow (mm/blow)
0	130			0	129			0	123		
1	150	20	20.0	5	137	8	1.6	5	141	18	10.60
1	167	17	17.0	5	149	12	2.4	5	151	10	9.40
1	180	13	13.0	5	178	15	3.0	5	165	14	8.67
1	190	10	10.0	5	194	14	2.8	5	178	13	
1	215	25	25.0	5	216	16	3.2	5	190	12	
						22	4.4	5	206	16	
								2	214	8	
Penetration depth		85				87				91	
Average DN (mm/blow)			17.0				2.90				2.94
Weighted average DN (mm/blow)			18.62				3.15				2.96

## 7. SURFACINGS

### 7.1 Introduction

The surfacing is a very important part of a LVSR pavement. It prevents gravel loss, eliminates dust, improves skid resistance, and reduces water ingress into the pavement. The prevention of water ingress into the pavement is especially important in LVSRs where moisture sensitive materials are often used.

There are a large number of surfacing options available for use on LVSRs and they offer a range of attributes which need to be matched to such factors as expected traffic levels and loading, locally available materials and skills, construction and maintenance regimes and the environment. Careful consideration should therefore be given to all these factors in order to make a judicious choice of surfacing to provide satisfactory performance and minimise life cycle costs.

### 7.2 Purpose and Scope

The main purpose of this chapter is to provide a broad overview of:

- The various types of surfacings, both bituminous and non-bituminous, that are potentially suitable for use on LVSRs, including their constituents
- The performance characteristics and typical service lives of the various types of surfacings
- The factors affecting the choice of surfacings

The chapter does not deal with the design of surfacings which is outside of the scope of the manual.

### 7.3 Bituminous Surfacing

#### 7.3.1 Surfacing types

The main types of thin bituminous surfacings that are typically used for LVSRs and are relatively low cost are as follows:

- 1) Surface dressing
- 2) Cape Seal
- 3) Otta seal
- 4) Cold mix asphalt
- 5) Slurry seal
- 6) Sand seal

The more common types of bituminous surfacings used on LVSRs are shown in Figure 7-1 and are discussed briefly below.

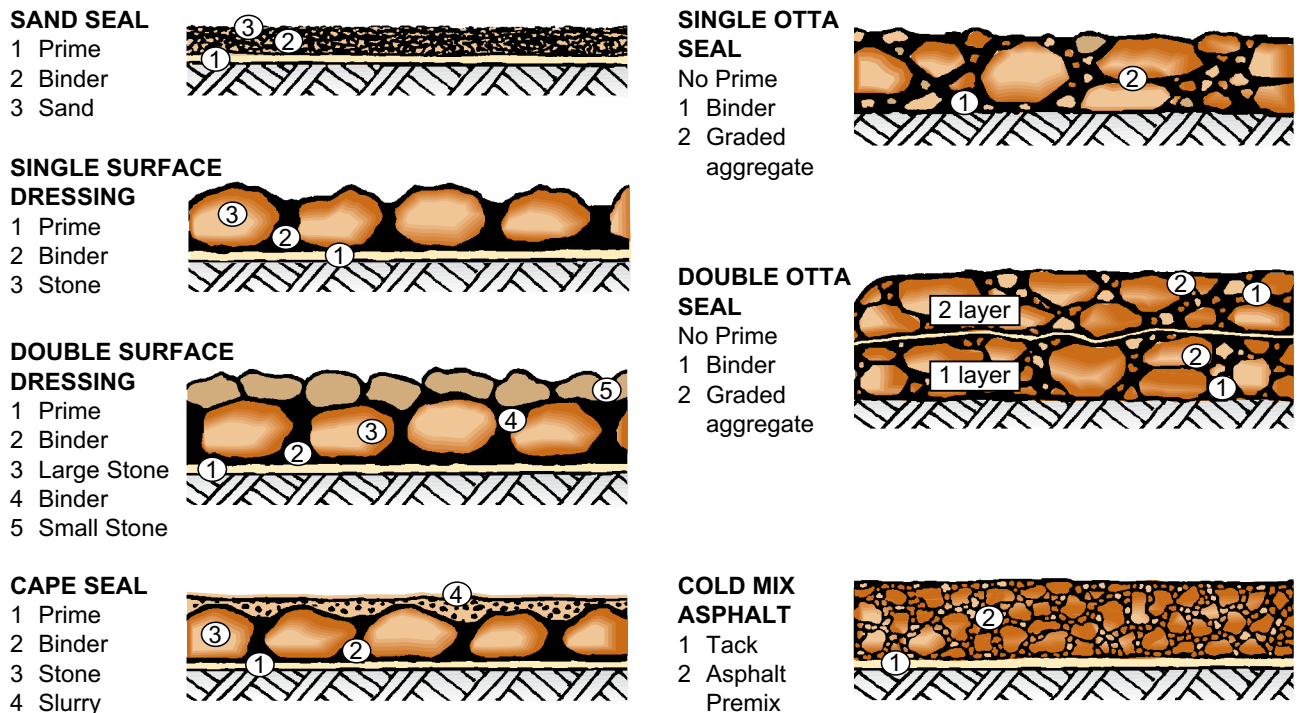

Figure 7-1: Common types of bituminous surfacings

### 7.3.1 Surface Dressing

This non-structural seal (single or double) consists of a spray(s) of bituminous binder followed by the application of a layer(s) of aggregate (stone chippings). The binder acts as a waterproofing seal preventing entry of surface water into the road structure while the chippings protect this film from damage by vehicle tyres.

### 7.3.2 Cape seal

A Cape Seal consists of a single 13 mm or 19 mm aggregate, penetrated with a binder and covered with a slurry seal. If 19 mm aggregate is used, the slurry is applied in two layers. The function of the slurry is to provide a dense void filler to enhance the stability of the single-sized coarse aggregate layer. The coarse aggregate is left proud to provide the macro texture for skid resistance.

### 7.3.3 Otta seal

An Otta seal is a sprayed bituminous surfacing comprising a mixture of graded aggregates ranging from natural gravel to crushed rock with relatively soft (low viscosity) binder, with or without a sand cover seal. This type of seal contrasts with the single sized crushed aggregate and relatively hard (high viscosity) binders used in Chip seals. The following are the main types of Otta Seals:

- **Single/Double Otta seal:**
  - open/medium/dense graded
  - Sand seal/no sand seal cover

### 7.3.4 Cold mix asphalt

Cold Mix Asphalt is a coarsely graded aggregate seal, similar in make-up to the Otta seal, but uses emulsion instead of hot bitumen as the binder. It is particularly suited for labour-based applications and can be constructed entirely with hand tools, simple equipment and a pedestrian roller for compaction. It relies on bitumen bonding and particle interlock more than on the strength of the aggregates. Because of its porous nature durability of the seal may be a concern.

### 7.3.5 Slurry seal

A Slurry Seal consists of a homogeneous mixture of pre-mixed materials comprising fine aggregate, stable-mix grade emulsion (anionic or cationic) or a modified emulsion, water and filler (cement or lime). The production of a slurry can be undertaken in simple concrete mixes or more sophisticated purpose-designed machines which mix and spread the slurry. The seal is used for treating various defects on an existing road surface such as arresting loss of chippings and restoring surface texture.

### 7.3.6 Sand seal

This seal consists of a spray of binder followed by the application of a coarse, clean sand or crusher dust as aggregate. This surfacing is used on low-volume roads, especially in drier regions, but can also be used for resealing, or for temporary by-passes. For new construction two layers are usually specified as single layers tend to be not durable. There is an extended curing period (typically 8 – 12 weeks) between the first and second seal applications to ensure complete loss of volatiles and thus prevent bleeding.

### 7.3.7 Typical service life

The life of a surface treatment depends on a wide range of factors such as the quality of the design, climate, pavement strength, binder durability, standard of workmanship, adequacy of maintenance etc. As a result, the service life of the surfacing can vary widely. In general, however, thin seals, which are typically used as temporary or holding measures in a phased surfacing strategy, have much shorter service lives (generally < 10 years) than double/combination seals (generally > 10 years).

Table 7-1 provides a broad indication of the relative service lives of different types of surface treatments which, together with other factors (Section 7-5) could assist in the selection of the type of surfacing in the context of a life-cycle cost analysis (Section 7-6).

**Table 7-1: Typical service life of surfacings\***

Type of surfacing	Typical service life (years)
(a) Thin seal/phased strategy	
• Single sand seal	2 - 3
• Double sand seal	3 - 6
• Slurry seal	3 - 5
• Single chip seal	6 - 8
(b) Double/combination seal strategy	
• Double chip seal	8 - 10
• Cold mix asphalt	8 - 10
• Single Otta seal	8 - 10
• Single Otta seal + Sand seal	10 - 12
• Cape seal (13 mm + single slurry)	10 - 12
• Cape seal (19 mm + double slurry)	12 - 15
• Double Otta seal	15 - 18

\* Assumes that timeous routine and periodic maintenance is carried out

### 7.3.8 Design of bituminous surfacings

Various methods have been developed by various authorities for the design of bituminous surfacings. The design of a particular type of surfacing is usually project specific and related to such factors as traffic volume, climatic conditions, available type and quality of materials.

The detailed design of surface treatments is beyond the scope of this manual. Relevant references dealing with such design are presented in the bibliography.

## 7.4 Non-Bituminous Surfacing

### 7.4.1 Main types

The main types of non-bituminous surfacings that are potentially suitable for use on LVSRs include the following

- (1) **Stone paving**
  - Cobble Stone
- (2) **Fired clay or concrete brick**
  - Unmortared/mortared joints
- (3) **Concrete**
  - Non-reinforced concrete

### 7.4.2 Stone paving

#### (a) Cobble Stone

Bricks suitable for road surfacing can be produced by firing clay in large or small scale kilns using coal, wood or some agricultural wastes as a fuel. The bricks must achieve certain strength, shape and durability requirements. The fired bricks are generally laid on edge to form a layer of typical 100 mm thickness on sand or sand-cement bedding layer and jointed similarly. Kerbs or edge restraints are necessary and can be provided by sand-cement mortared fired bricks. The fired bricks are normally laid in a herring bone or other approved pattern to enhance load spreading characteristics. Un-mortared brick paving is compacted with a plate compactor and the jointing sand is topped up if necessary. For mortar bedded and jointed fired clay brick paving, no compaction is required.



Photo 7-1: Example of Cobble Stone surfacing

### 7.4.3 Fired clay brick

Bricks suitable for road surfacing can be produced by firing clay in large or small scale kilns using coal, wood or some agricultural wastes as a fuel. The bricks must achieve certain strength, shape and durability requirements. The fired bricks are generally laid on edge to form a layer of typical 100 mm thickness on sand or sand-cement bedding layer and jointed similarly. Kerbs or edge restraints are necessary and can be provided by sand-cement mortared fired bricks. The fired bricks are normally laid in a herring bone or other approved pattern to enhance load spreading characteristics. Un-mortared brick paving is compacted with a plate compactor and the jointing sand is topped up if necessary. For mortar bedded and jointed fired clay brick paving, no compaction is required.



Photo 7-2: Example of burnt Clay Brick surfacing (Herringbone pattern)

### 7.4.4 Concrete bricks

Concrete brick paving is a well-established technique for applications from light pedestrian to rural roads to very heavy vehicle loading. The success of the technique is based on the proven ability of individual bricks to effectively disperse load to adjacent bricks through the sand joints. Concrete brick pavements have good load spreading properties especially on low strength subgrades. They are also well suited for heavily stressed turning areas or intersections and are re-usable if road base failure occurs. They can be laid in a variety of patterns (e.g. Herringbone, Stretcher) depending on user preference.

Concrete bricks are produced with a maximum aggregate size of 6 mm and typical dimensions of 200 x 100 x 70 mm thick with a minimum crushing strength of 25 MPa. Bricks below this strength are unlikely to provide adequate resistance to traffic impact and are likely to break or wear rapidly or irregularly.



Photo 7-3: Example of concrete brick paving (Herringbone pattern)

#### 7.4.5 Un-reinforced/reinforced concrete

Unreinforced or reinforced concrete slab pavements, of varying thickness (as little as 50 mm with ultra-thin, mesh-reinforced, surfacings) can be used to provide a high strength, durable road surface with very low maintenance requirements. Concrete of minimum 20 MPa quality is required to be used. Joints are required to accommodate thermal expansion and contraction. Whilst it would normally be difficult to justify the use of concrete surfacing on LVSRs, this may be necessary on very steep grades, particularly in high rainfall areas, where bituminous or other types of non-bituminous surfacings may not be feasible.



Photo 7-5: Example of reinforced concrete surfacing

### 7.4.5 Typical service lives

The service life of a non-bituminous surfacing is relatively much longer than for a bituminous surfacing. This is due largely to the superior durability of the surfacing material, mostly natural stone, which is very resistant to the environment. Provided that the foundation support and road drainage are adequate, non-bituminous surfacings require relatively little maintenance and will last almost infinitely.

### 7.4.6 Design of non-bituminous surfacings

The design approach for non-bituminous surfacings is similar to that of the more traditional bituminous surfacings, in that design inputs are principally traffic volumes, subgrade soil conditions and other environmental factors.

A number of design catalogues have been developed based on a combination of experience gained in LVR trials in other countries; existing published design details; engineering judgment and, where relevant, correlation with bituminous LVR design catalogues in terms of equivalent structural number. The designer is referred to other publications dealing with the design of non-bituminous surfacings, such as the *Ethiopia Design Manual for Low Volume Roads*.

## 7.5 Factors Affecting Choice of Surfacing

The choice of the appropriate surfacing type in a given situation will depend on the relevance or otherwise of a number of factors, including the following:





- Traffic (volume and type)
- Pavement (type – strength and flexural properties)
- Materials (type and quality)
- Environment (climate – temperature, rainfall, etc.)
- Operational characteristics (geometry – gradient, curvature, etc.)
- Safety (skid resistance - surface texture, etc.)
- Construction (techniques and contractor experience)
- Maintenance (capacity and reliability)
- Economic and financial factors (available funding, life cycle costs, etc.)
- Other external factors

The suitability of various types of surfacings for use on LVSRs, in terms of their efficiency and effectiveness in relation to the operational factors outlined above is summarised in Table 7-2. Whilst not exhaustive, the factors listed in the table provide a basic format which can be adapted or developed to suit local conditions and subsequently used to assist in making a final choice of surfacing options. These options can then be subjected to a life cycle cost analysis and a final decision made with due regard to prevailing economic factors and be compatible with the overall financial situation.

**Table 7-2: Suitability of various surfacings for use on LVSRs**

Surfacing attributes	Thin seal/phased strategy				Double/Combination seal strategy							
	SSS	DSS	SLS	SSD	SSD+SS	DSD	SOS	SOS+SS	DOS	CS 13 mm	CS 19 mm	CMA
Ease of design	Green	Green	Green	Orange	Orange	Orange	Red	Red	Red	Orange	Orange	Yellow
Ease of construction	Green	Green	Green	Orange	Orange	Orange	Red	Red	Red	Orange	Orange	Green
Service life	Red	Red	Red	Red	Orange	Yellow	Orange	Green	Green	Yellow	Green	Yellow
Suitability for LBM	Green	Green	Green	Yellow	Yellow	Yellow	Orange	Orange	Orange	Yellow	Yellow	Green
Risk of poor mtce capability	Red	Red	Red	Red	Orange	Orange	Orange	Green	Green	Green	Green	Yellow
High skid resistance	Red	Red	Red	Green	Yellow	Green	Orange	Orange	Orange	Yellow	Green	Red
Early road marking	Orange	Orange	Green	Green	Orange	Green	Red	Red	Red	Green	Green	Green
Suitability for turning actions	Red	Red	Red	Red	Orange	Orange	Yellow	Yellow	Yellow	Yellow	Yellow	Yellow
Sensibility to material quality	Orange	Orange	Orange	Red	Red	Red	Green	Green	Green	Red	Red	Yellow
Constr. sensitivity * to gradient (>8%)	Red	Red	Red	Red	Orange	Orange	Red	Red	Red	Orange	Orange	Yellow

	Very good	<i>SSS-Single Sand Seal</i>
	Good	<i>DSS-Double Sand Seal</i>
	Reasonable	<i>SLS-Slurry Seal</i>
	Poor/not suited	<i>SSD-Single Surface Dressing</i>
		<i>SOS-Single Otta Seal</i>
		<i>DSD-Double Surface Dressing</i>
		<i>DOS-Double Otta Seal</i>
		<i>CS-Cape Seal 13/19 mm+Single/Double SLS</i>
		<i>CMA-Cold Mix Asphalt</i>

## 7.6 Life-Cycle Cost Analysis

In order to determine the most cost-effective type of surfacing to use on a LVSR, it is necessary to undertake a life-cycle cost (LCC) analysis of the feasible options. Such an analysis focuses on the cost of the various surfacing options by comparing the construction and maintenance costs during the life of the road according to the criterion of minimum total (life cycle) costs.

The main inputs for undertaking a LCC analysis include:

- Assumed service life of surfacing
- Construction cost for surfacing options
- Maintenance cost for surfacing options
- Discount rate

The analysis assumes that the vehicle operating costs imposed by the various options are similar due to very small differences in their roughness levels.

In the life-cycle analysis process, the alternative pavement/surface options are compared by converting all the costs and benefits that may occur at different times throughout the life of each option to their present day values. Such values are obtained using discounted cash flow techniques involving the use of an appropriate discount rate, to determine the Present Value (PV) of the pavement/surface options. The lowest PV option represents the financially optimum solution. The discount rate used must be representative of the country.

Figure 7-2 shows the manner of undertaking a LCC analysis by comparing the PV of all costs and maintenance interventions that occur during a given analysis period. The example is a hypothetical one used for illustrative purposes only and does not necessarily reflect a real life situation.

An example of a LCC comparison between a single Otta Seal plus sand seal and a Double Surface Dressing is presented in Annex 7A.

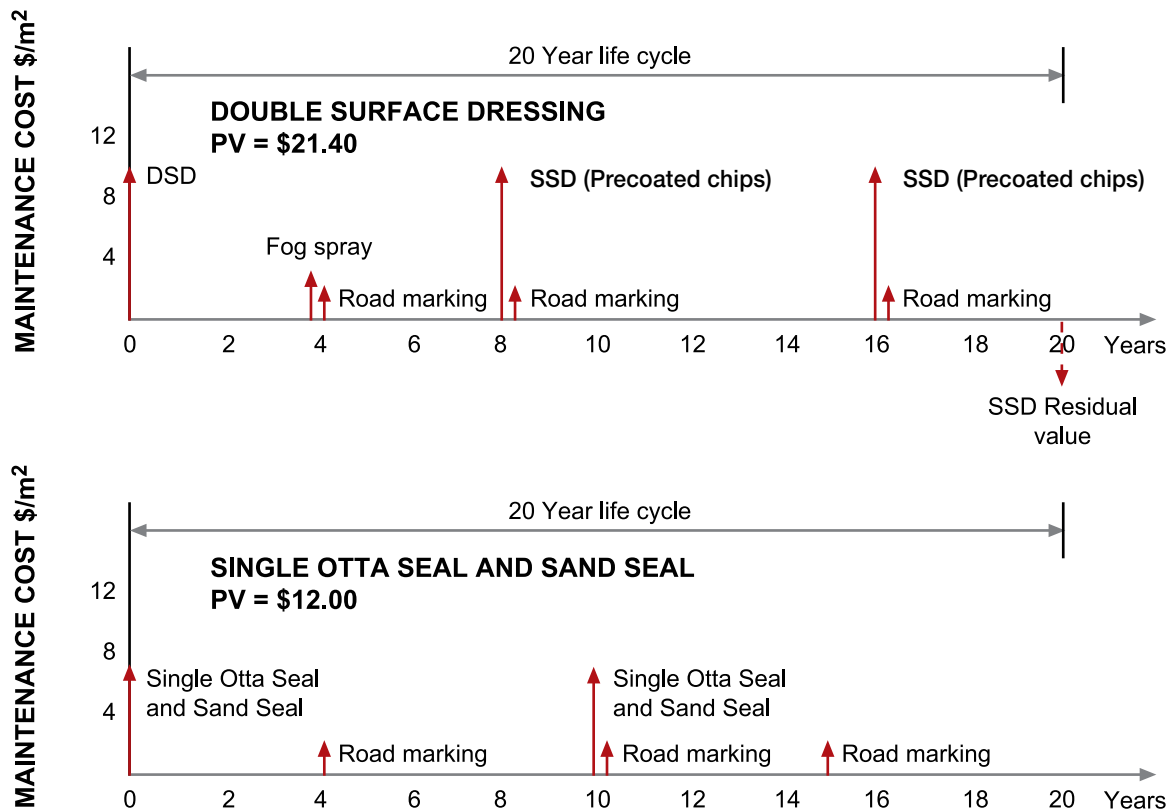

Figure 7-2: Cost components of a LCC between a single Otta seal + sand seal and a double Surface Dressing

## ANNEX 7A: Life Cycle Cost Comparison between a Single Otta Seal plus Sand Seal and a Double Chip Seal (hypothetical only)

1. An illustrative example of a life cycle cost analysis is presented below of the more conventional double Chip Seal with the equivalent alternative of the single Otta Seal plus a sand seal cover. The analysis assumes that “best practice” is followed in terms of maintenance intervention measures being carried out at the appropriate time.
2. The life cycle cost analysis is based on discounted cash flow techniques, employing the Present Worth Method of economic analysis. This method involves the conversion of all costs incurred in the construction and subsequent maintenance of the seal, including the provision of road marking, to a common base year of Present Value (PV) costs. It is assumed that the vehicle operating costs are similar for both seals. The totals of the PV's of costs for both seals can then be compared with each other. The difference in these PV's gives a good relative comparison of the life cycle costs of the seals.

**Table 7A-1: Life cycle cost analysis for Double Chip Seal**

Activity	Years after construction	Base cost/m <sup>2</sup> (\$)	8% Discount factor	PV of cost/m <sup>2</sup> (\$)
1. Construct Double Chip Seal	-	10.00	1.0000	10.00
2. Fog spray	4	02.00	0.7350	1.47
3. Road marking	4	00.96	0.7350	0.71
4. Single Chip Seal (pre-coated)	8	10.00	0.5403	5.40
5. Road marking	8	00.96	0.5403	0.52
6. Fogspray	12	2.00	0.3971	0.79
7. Road marking	12	00.96	0.3971	0.38
8. Single Chip Seal (pre-coated)	16	10.00	0.2919	2.92
9. Road marking	16	00.96	0.2919	0.28
10. Residual value of surfacing	20	(5.00)	0.2145	(1.07)
				Total \$21.40/m <sup>2</sup>

Table 7A-2: Life cycle cost analysis for single Otta Seal + sand seal cover

Activity	Years after construction	1999 Base cost (\$)	8% Discount factor	PV of cost (\$)
1. Construct single Otta Seal + sand Seal	-	7.25	1.00	7.25
2. Road marking	5	0.96	0.6806	0.65
3. Single Otta reseal	10	7.25	0.4632	3.36
4. Road marking	10	0.96	0.4632	0.44
5. Roadmarking	15	0.96	0.3152	0.30
Assume life span of 20 years. thus, no residual value.				0.00
				Total \$12.00/m <sup>2</sup>

**Conclusion:**

The above calculations indicate that, in LCC terms, the cost of the Double Chip seal option is approximately 78% higher than the single Otta seal plus sand seal cover. As is apparent, the cost advantage of the latter over the former is derived mainly as a result of lower initial construction costs, longer seal life and less maintenance interventions. The difference would be even greater if any haulage of aggregate is involved or if screened gravel within the project area were used for the Otta Seal rather than crushed aggregate.



## 8. DRAINAGE

### 8.1 Introduction

Effective internal and external drainage are of crucial importance to the good performance of LVSRs which are generally constructed from relatively moisture-sensitive, naturally occurring materials. Lack of good drainage can lead to ingress of water in the road structure, subsequent weakening of the pavement materials and eventual failure of the road. It is therefore of critical importance to ensure that when a gravel road is being upgraded to a sealed standard that the existing drainage system is functioning properly and, if this is not the case, to undertake the necessary improvements. Such improvements need to be considered carefully because judging the effectiveness of different options is quite difficult and the cost of the options can vary greatly.

### 8.2 Purpose and Scope

The purpose of this chapter is to provide a drainage framework to assist the designer in evaluating the adequacy of existing infrastructure and the need for new infrastructure when low volume gravel roads are upgraded to a paved standard. The general approach adopted is to make maximum use of existing drainage facilities and to evaluate their adequacy to ensure that the performance of the road will not be adversely affected by inadequate drainage infrastructure. The chapter does not deal with detailed drainage design which is outside of the scope of the manual.

The chapter addresses the following drainage-related issues:

- Hydrology
- Structural loading
- Road level
- Road surface drainage
- Sub-surface drainage
- Drainage channels
- Culverts
- Low level structures
- High level structures
- Subsurface drainage

### 8.3 Hydrology

It is necessary to undertake a hydrological analysis in order to obtain information on runoff and stream flow characteristics. Such information is used as a basis for checking the adequacy of the hydraulic design of the existing drainage facilities such as culverts, low level structures and drainage channels or for designing new facilities, where required.

#### 8.3.1 Return period

Recommended return periods for different types of structures on low volume roads should be in accordance with national standards. The return period of the existing infrastructure should be determined and should then be compared to the values recommended in the national standards. Previous experience with regard to the adequacy of the facilities as experienced by both road users and the Roads Authority should be taken into account in this process.

### 8.3.2 Methods of design flood estimation & hydraulic calculations

Various methods for the determination of the design flood can be used. The designer is referred to the guidelines available on design flood determination.

### 8.3.3 Hydraulic calculations

Hydraulic calculations are necessary to determine or evaluate the size and spacing of drainage structures. Other factors to be determined for the design of the drainage structures include flow velocities, flow depths and flow patterns. Design procedures are left to the designer, who is referred to available guidelines.

## 8.4 Road Level

### 8.4.1 Crown height

The crown height of a LVSR, i.e. the vertical distance from the bottom of the side drain to the finished road level at the centre line, is a critical parameter that correlates well with the in-service performance of pavements constructed from naturally occurring materials. This height must be sufficiently great to prevent moisture ingress into the potentially vulnerable outer wheel track of the carriageway for which a minimum value of 0.75 m is recommended.

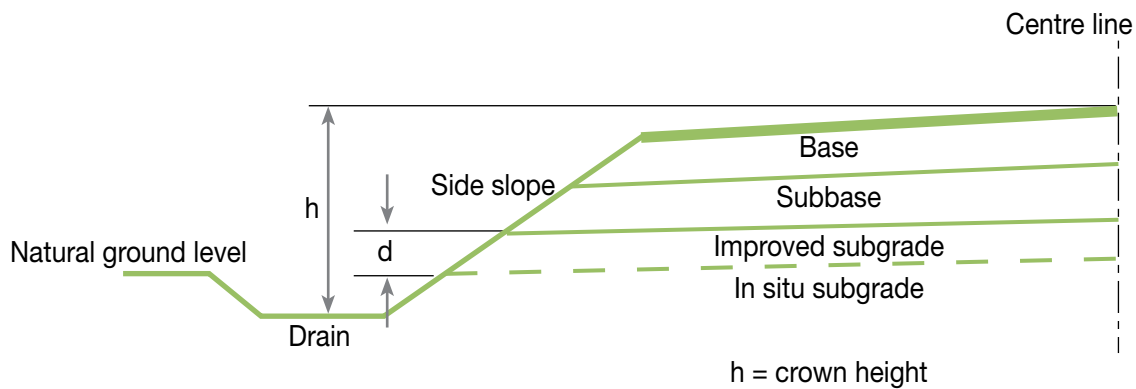

Figure 8-1: Crown height for LVSRs

The recommended minimum crown height of 0.75 m applies to unlined drains in relatively flat ground (longitudinal gradient,  $g$ , less than 1%). The recommended values for sloping ground ( $g > 1\%$ ) or where lined drains are used, for example, in urban or peri-urban areas, are shown in Table 8-1.

Table 8-1: Recommended crown height in relation to drain type and longitudinal gradient

Crown height (m)			
Unlined drains		Lined drains	
$g < 1\%$	$g > 1\%$	$g < 1\%$	$g > 1\%$
0.75	0.65	0.65	0.50

In addition to observing the crown height requirements, it is also equally important to ensure that the bottom of the subbase is maintained at a height of at least 150 mm above the existing ground level (distance  $d$  in Figure 8-1). This is to minimise the likelihood of wetting up of this pavement layer due to moisture infiltration from the drain.

Because of the critical importance of observing the minimum crown height and minimum height of the bottom of the subbase above existing ground level, along the entire length of the road, the measurement of this parameter should form an important part of the drainage assessment carried out during the preliminary road evaluation (ref. Chapter 2). This is to ensure that any existing drainage problems associated with depressed pavement construction, often observed on gravel roads that have evolved over time with no strict adherence to observing minimum crown heights (see Figure 8-.2), is avoided.

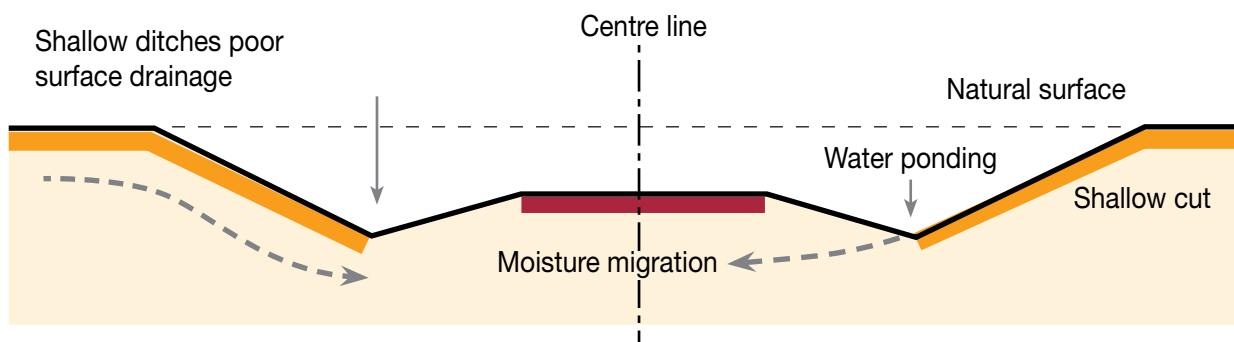

Figure 8-2: Potential drainage problems associated with depressed pavement construction

#### 8.4.2 Deep cuttings and high embankments

Existing deep cuttings and high embankments require special attention with regard to drainage to ensure that they will be stable when the road is upgraded.

The adequacy of the drainage of deep cuttings should be investigated. Where necessary, measures such as cut-off (interceptor or catch-water) drains up-slope and behind the cut face must be provided (see Section 8.7.4). The application of other techniques such as reducing the batter should only be used where absolutely necessary.

The erosion of the faces of the slopes should also be addressed where necessary. The stability of fills and the role of stormwater should also be investigated in order to evaluate the need for kerbs, down chutes, etc.

### 8.5 Road Surface Drainage

In order to shed rain water falling on the surface of the road, it is necessary to ensure that the cross-section profile is constructed with adequate camber or cross-fall. The term camber implies two slopes away from the centre line to the shoulders while cross-fall implies a single slope from shoulder to shoulder.

The recommended camber or cross-fall values for sections of road which are not superelevated are shown in Table 8-2. It is assumed that, as a matter of policy, shoulders will be sealed because of the many advantages that this offers.

Table 8-2: Recommended camber and cross-fall values for LVSRs

Road type	Carriageway and shoulder slope (%)		
	Topography		Camber (CA) or Cross-fall (Cr)
	Flat ( $g < 1\%$ )	Other ( $g > 1\%$ )	
Two-lane	2.5	2.0	Ca
Single-lane	3.5	3.0	Cr

## 8.6 Subsurface Drainage

Adequate stormwater drainage may in some cases alleviate the need for expensive subsurface drainage. Subsurface drains need only be installed when seepage or high water tables are encountered and not as a general policy in cuts.

Localised seepage can be corrected in various ways but seepage along pervious layers combined with changes in road elevation (grade) may require subsurface drains as well as ditches (see Figure 8-3) or, sometimes, cut-off drains transversely across the road in situations where there is a likelihood of water movement under pavement layers from higher positions on subgrade rock.

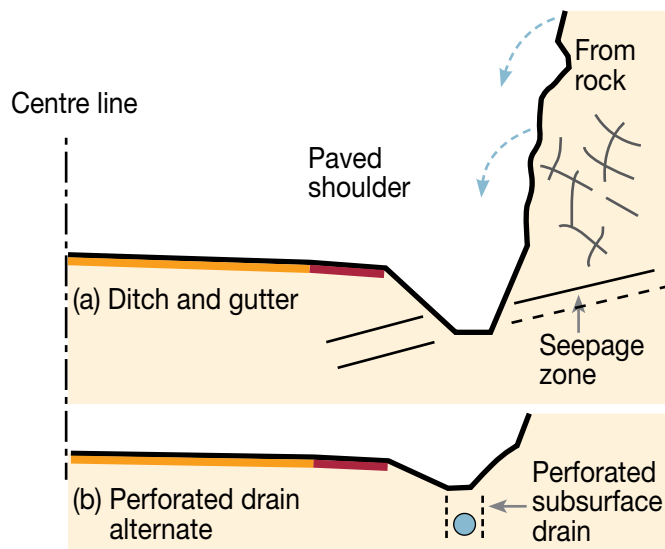

Figure 8-3: Beneficial interception of surface runoff and subsurface seepage

## 8.7 Drainage Channels

Several types of drainage measures may be used for achieving effective external drainage of a LVSR. Such measures seek to prevent water from damaging the pavement or surrounding environment by safely channeling it away from or across the road, avoiding erosion and instability of embankments and cuttings. They include:

- Side drains
- Erosion control devices: scour checks and lined drains
- Mitre drains
- Interceptor (cut-off or catch-water) drains

The design of a drainage channel to carry a given discharge is accomplished in two stages, as follows:

- (1) **Stage A:** Decide on a cross-section that will carry the design discharge on a given slope.
- (2) **Stage B:** Determine the degree of protection required to prevent or minimise erosion.

To accomplish the above, the existing drainage channels should be evaluated to determine whether they need to be improved. The investigation should also address the need for other drainage channels which do not exist, but which are required.

The following section highlights the important features of drainage channels that should be used as a yardstick for assessing the adequacy of the existing channels.

### 8.7.1 Side drains

As illustrated in Figure 8-4, side drains (also referred to as table drains) can be constructed in three forms, V-shaped, rectangular or trapezoidal. These drains need to have sufficient capacity to collect all rainwater from the road carriageway and dispose of it quickly and in a controlled manner to minimise damage.

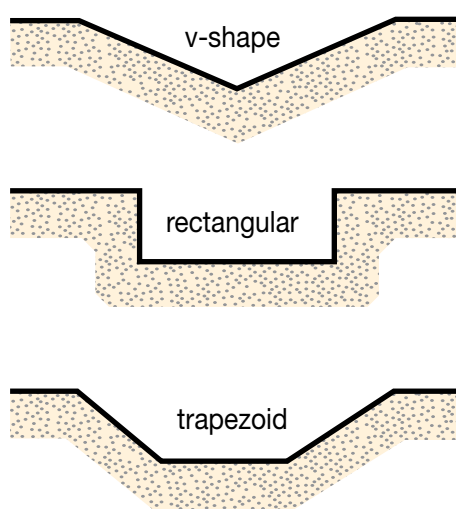

Figure 8-4: Types of side drains

The **V-shape** is the standard shape for ditches constructed by a motor grader. It can easily be maintained by heavy equipment. However, it carries a lower capacity than other cross section types.

The **rectangular shape** requires less space but needs to be lined with bricks, mortared stone or concrete, to maintain its shape. This shape is often used in urban or peri-urban areas where there is limited space for drainage.

The **trapezoid shape** carries a relatively high flow capacity and by carefully selecting the right gradients for its side slopes, will resist erosion. This shape is suited to labour-based work.

The choice of side drain cross-section depends on factors such as:

- The required hydraulic capacity, maintenance arrangements, space restrictions, traffic safety (where possible, side drains should never be deeper than 0.50 metres) and any other requirements relating to the height between the crown of the pavement and the drain invert

- The cost and erosion potential of the drain. For example, in soft materials the trapezoidal drain may be easy to construct and to maintain whereas in hard materials (e.g. shales) it could be costly and unnecessary to construct this type of drain and, instead, the use of more outlets/mitre drains may be the more cost-effective solution

The following recommendations are made regarding desirable slopes for side drains:

- To avoid ponding and siltation minimum slope should be in the range 1 - 2%.
- Drains steeper than 1% may need scour protection, depending on the erodability of the soil and the vegetative cover.

### 8.7.2 Erosion control devices

- Scour checks:** The scour check acts as a small dam and, when naturally silted up on the upstream side, effectively reduces the gradient of the drain on that side, and therefore the velocity of the water. Scour checks are usually constructed with natural stone or with wooden stakes. Masonary or concrete scour checks require less maintenance but are more expensive to construct.

Typical designs for scour checks are shown in Figure 8-5

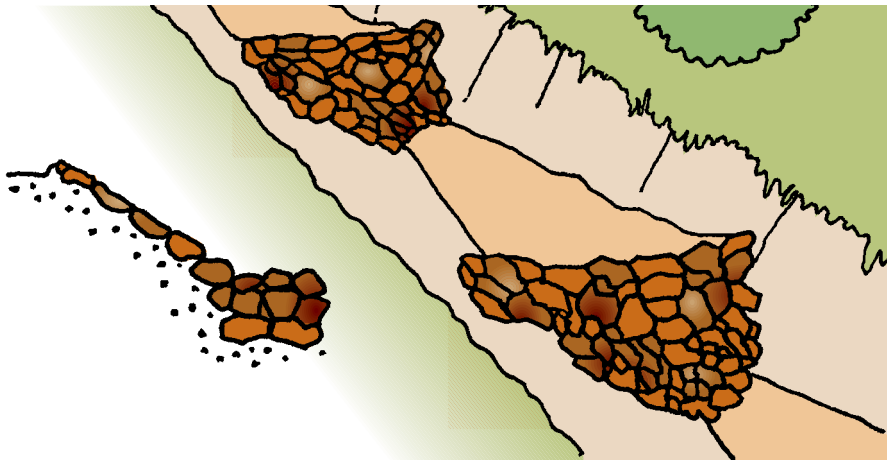

Figure 8-5: Typical natural stone scour checks

The distance between scour checks depends on the road gradient and the erosion potential of the soils. Table 8-3 shows recommended values but these may need to be modified for more erodible soils.

Table 8-3: Spacing between scour checks

Road Gradient (%)	Scour check interval (m)
3	Not required
4	17
5	13
6	10
7	8
8	7
9	6
10	5
12	4

- (b) **Lined drains:** Depending on the road gradient (typically in excess of 8%), the strength of the material in which the drains are excavated and the velocity of the runoff they are expected to carry, side drains may need to be lined. Such lining can be made from concrete, stone or bricks. Rock, if available, is the preferred building material and can be laid as a dry or wet masonry. The size of the rocks should be a minimum of 200 mm to avoid being washed away.

### 8.7.3 Mitre drains

Mitre drains are constructed at an angle to the centre line of the road. They are intended to remove water from a drain next to the toe of a fill, and to discharge it beyond the road reserve boundary. Several mitre drains can be constructed along the length of a drain, as the concentration of water in the drain should ideally be dispersed and its speed correspondingly reduced before discharge. Speed can be reduced not only by reducing the volume, and hence the depth, of flow but also by positioning the mitre drain so that its toe is virtually parallel to the natural contours. A typical layout of a mitre drain is shown in Figure 8-6.

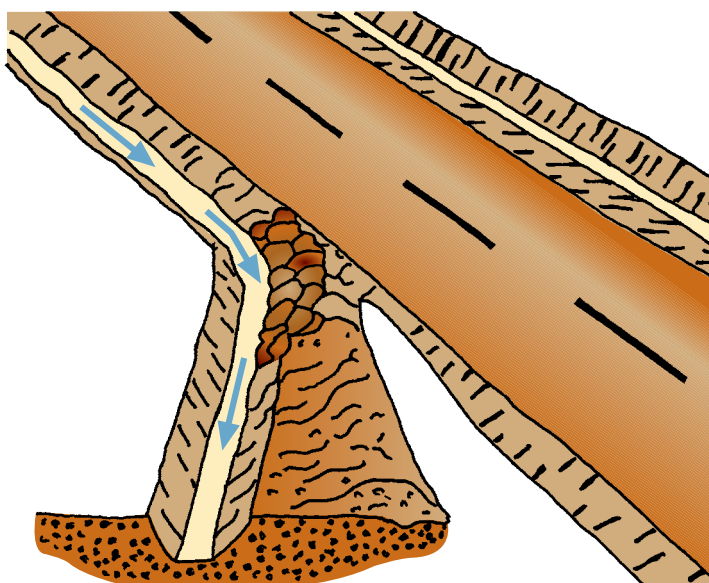

Figure 8-6: Typical layout of mitre drain

The downstream face of a mitre drain is usually protected by stone pitching, since the volume and speed of flow of water which it deflects may cause scour and ultimately lead to breaching of the mitre drain.

In order to ensure that water flows out of the side drain into the mitre drain, a block-off is required as shown in Figure 8-7. It is essential that the mitre drain is able to discharge all the water from the side drain. If the slope of the mitre drain is insufficient, the mitre drain needs to be made wide enough to ensure this.

The desirable slope of the mitre drains is 2%. The gradient should not exceed 5% otherwise there may be erosion in the drain or on the land where the water is discharged. The drain should lead gradually across the land, getting increasingly shallower. Stones may need to be laid at the end of the drain to help prevent erosion.

In flat terrain, a small gradient of 1 % or even 0.5% may be necessary to discharge water, or to avoid very long drains. These low gradients should only be used when absolutely necessary. The slope should be continuous with no high or low spots. For flat sections of road, mitre drains are required at frequent intervals to minimise silting.

In mountainous terrain, it may be necessary to accept steeper gradients. In such cases, appropriate soil erosion measures should be considered.

The angle between the mitre drain and the side drain should not be greater than 45 degrees. An angle of 30 degrees is ideal. If it is necessary to take water off at an angle greater than 45 degrees, it should be done in two or more bends so that each bend is not greater than 45 degrees (Figure 8-7).

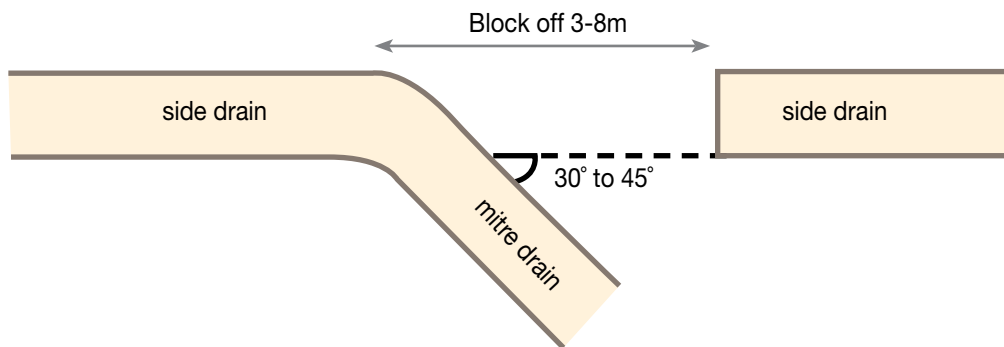

**Figure 8-7: Mitre drain angle greater than 45 degrees**

The spacing of mitre drains is highly dependent on the material/erodability characteristics, storm duration/intensity and gradient. Table 8-4 gives the maximum spacing of mitre drains. However, such spacings should normally be more frequent than this and values as low as one every 20 m may be required to avoid damage to adjacent land, especially where it is cultivated.

Table 8-4: Maximum spacing of mitre drains

Road Gradient (%)	Maximum mitre drain interval (metres)
12	40
10	80
8	120 <sup>1</sup>
6	150 <sup>1</sup>
4	200 <sup>1</sup>
2	80 <sup>2</sup>
<2	50

Notes: 1. A maximum of 100 m is preferred but not essential

2. At low gradients silting becomes a problem

#### 8.7.4 Interceptor (cut-off or catch-water) drains

Interceptor drains are ditches that have been constructed more or less parallel to the road. Their function is to catch and lead away water coming from higher lying areas before it reaches the road or to direct water to where it can safely cross the road at constructed water crossings, such as culverts, bridges and drifts.

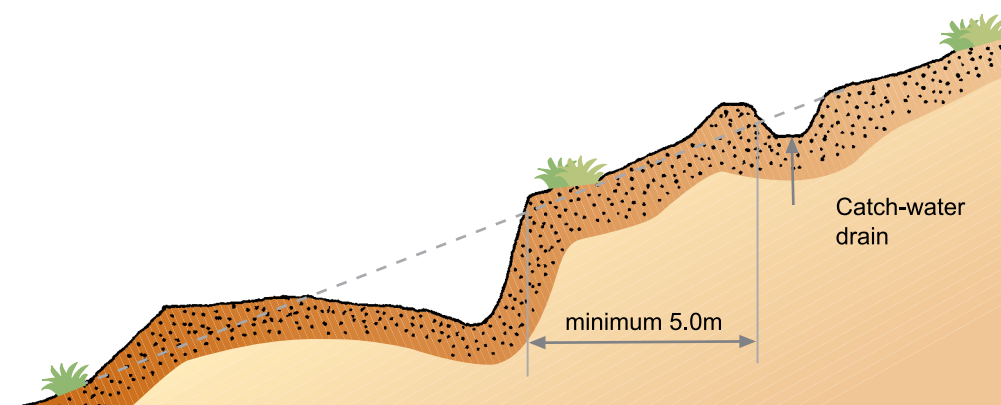

Figure 8-8: Interceptor, cut-off or catch-water drain

Interceptor drains are seldom lined. They usually have a trapezoidal cross section and are constructed with the undisturbed topsoil of the area as their inverts. They can readily be grassed as a protection against scour and transverse weirs can also be constructed to reduce flow velocities. Wherever possible, the drains should be diverted to a natural watercourse.

## 8.8 Culverts

The capacity of existing culverts should be determined to ascertain whether they are adequate for the required return period. If less than the 1: 2 year flood, they should be upgraded to accommodate the 1: 5 year flood (ref. Table 8-1). If more than the 1:2 year flood, but less than the 1:5 year flood, the designer must decide in terms of the characteristics of the area and previous experience whether it is justified to upgrade the capacity. In the case where the 1:5 year flood can be accommodated, existing culverts should be used as they are.

Existing culverts should also be checked for scour, especially at the outlets. Where warranted, scour protection or energy dissipation must be accomplished.

Where new culverts are required, careful consideration should be given to choosing the most appropriate, cost-effective type for a particular application taking account of such factors as purchase and transport costs. Regular maintenance of culverts is also critically important to ensure unimpeded water flow. When laid at a minimum grade of about 2%, desirable self-cleansing of the culvert can be achieved.

The following types of culverts are generally available:

- Corrugated metal nestable pipe sections
- Corrugated metal multi-plate arch
- Prefabricated concrete pipe and portal units
- In situ circular concrete culverts or arch culverts
- Large concrete bricks and small reinforced slabs fabricated on site

The designer is referred to the various available guidelines for the design of culverts.

## 8.9 Low Level Structures

Low level structures typically include:

- **Drifts:** Provide a permanent running surface for traffic through a stream or river bed, and are typically paved with reinforced concrete, masonry or hand-packed stone
- **Causeways:** Are an intermediate drainage structure with service levels superior to drifts, but inferior to low level bridges. They are normally used where flows would make drifts impassable for extended periods of time
- **Low level bridges:** provide a river crossing designed to experience zero or very limited damage when submerged. Although they occasionally result in short-term delays due to flooding, they are usually recommended for low volume roads, due to their overall cost-effectiveness

When “as-built” drawings are available for the above types of low level structures, the designer should establish whether the existing structure can carry the expected loads. If such drawings are not available, then the following should be done:

- The structure should be thoroughly inspected visually to establish whether there are any signs of distress or failure, and if there are, to evaluate the implications thereof
- If the condition of the structure appears to be sound and no significant increase in traffic volumes or changes in the vehicle composition using the road are expected, the structure may be used as it is

- If the condition of the structure appears to be sound, but a significant increase in traffic volumes or a change in traffic composition is expected, slab thickness, reinforcement details and span lengths should be determined and an analysis should be undertaken to establish whether the existing structure is adequate to carry the expected loads. The structure should be strengthened or replaced only if necessary
- If the structure is not in good condition, i.e. when signs of distress and failure are observed, the implications of these must be evaluated in the light of the expected loading conditions in order to establish whether the structure is adequate, or whether repairs, upgrading or replacement is necessary

The designer is referred to the various available codes of practice for the design of highway bridges and culverts which should be used for the evaluation of the structural loading of bridges and culverts.

### 8.10 High Level Bridges

In principle, the approach to evaluating the adequacy of existing high level bridges is as described above for low level structures.

Where new water crossings are considered necessary on the existing road, In general, the use of high level bridges on low volume roads should only be considered if economically justifiable otherwise, as far as possible, the existing low level structures should be retained with any necessary remedial works.

Part: **C**

**Design**

**Considerations**

# 1. DESIGN CONSIDERATIONS

## 1.1 Introduction

Traditional approaches to the design of LVSRs in the Southern African region have stemmed from technology and research carried out in the environments prevailing in Europe and the USA over 40 years ago. However, the environments prevailing in the Southern African region, including that in Malawi, are very different in terms of climate, traffic, materials and road users. It is therefore not surprising that many of the imported approaches, designs and technologies are inappropriate for application in Malawi.

Fortunately, technology, research and knowledge about LVSRs carried out in the Southern African environment, including Malawi, have advanced significantly and not only question much of the accepted wisdom on LVSR provision but also show quite clearly the need to revise conventional approaches. Much of this research was aimed at deriving local specifications, designs and techniques for improving the cost-effective provision of low volume roads sealed with a bituminous or non-bituminous surfacing. In addition, advances have been made in the provision of more appropriate geometric, drainage and pavement design standards coupled with innovative construction techniques and methods that optimise the use of local labour.



Research carried out in Malawi has provided a sound basis for understanding how LVSRs deteriorate, leading to the development of revised, standards, specifications and design methods that make better use of locally available materials.

## 1.2 Design Approach

The general approach to the design of LVSR pavements differs in a number of respects from that for HVRs. For example, conventional approaches usually produce very low risk designs and associated high levels of serviceability requiring numerous layers of selected materials. However, such standards can hardly be justified when traffic levels are relatively low. Instead, more appropriate designs are required to provide a pavement that is appropriate to the road environment in which it operates and fulfills its function at minimum life cycle cost at an optimal level of service.

In order to upgrade unsealed roads to a low volume sealed road (LVSR) standard as cost-effectively as possible, optimum use needs to be made of the in situ materials within the prevailing road environment. To this end, the main emphasis is on using the existing road pavement structure without disturbing its inherent strength derived over many years from consolidation by traffic, coupled with wetting and drying cycles, and on only adding a new layer(s), if necessary, to cater for the design traffic. The Dynamic Cone Penetrometer (DCP) method of pavement design lends itself to such an approach.

The adoption of appropriate designs for LVSRs does not mean an increased risk of failure but, rather, requires a greater degree of pavement engineering knowledge, experience and judgment and the careful application of fundamental principles of pavement and material behaviour derived from local or regional research. The primary requirements for mitigating against the risk of LVR failure are to ensure that the pavements are well drained, the road is timeously and effectively maintained and axle loads are controlled to acceptable limits.

Regional research has also shown that the relative influences of road deterioration factors are significantly different for low volume roads compared with higher volume roads. A critical observation is that for sealed roads carrying below 1.0 MESA, pavement deterioration was controlled mainly by how the road responded to environmental factors, such as moisture changes in the pavement layers, fill and subgrade, rather than to traffic as illustrated in Figure 1-1. The appropriate design options for low volume roads therefore need to be responsive to a wide range of factors as captured in the road environment with the most critical being internal and external drainage.

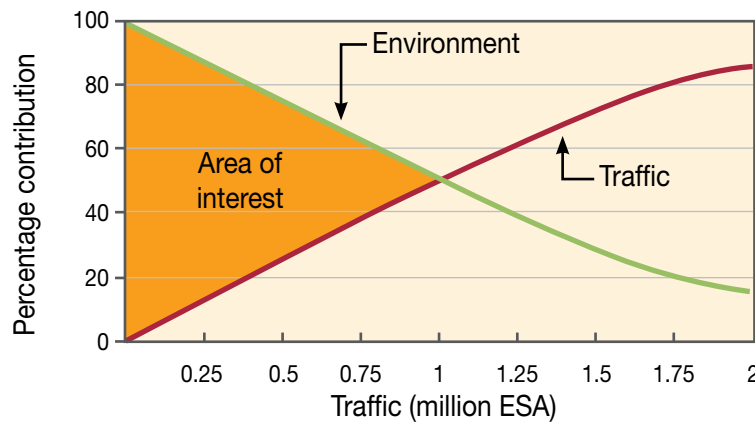

Figure 1-1: Traffic loading versus dominant mechanism of pavement distress (Schematic only)

### 1.3 The Road Environment

The pavement design process must be fully responsive to the road environment in Malawi. This environment can be considered to encompass both local climate (rainfall, temperature range and evaporation), drainage (effectiveness of drains, carriageway crossfall and crown height) and topographic and sub-soil conditions.

The various road environment factors that must be considered in the design of LVSRs are illustrated in Figure 1-2. These factors can impact either on the surface of the road, the pavement or the geometric aspects and should all be considered in the design of the road as discussed in Part B of the manual.

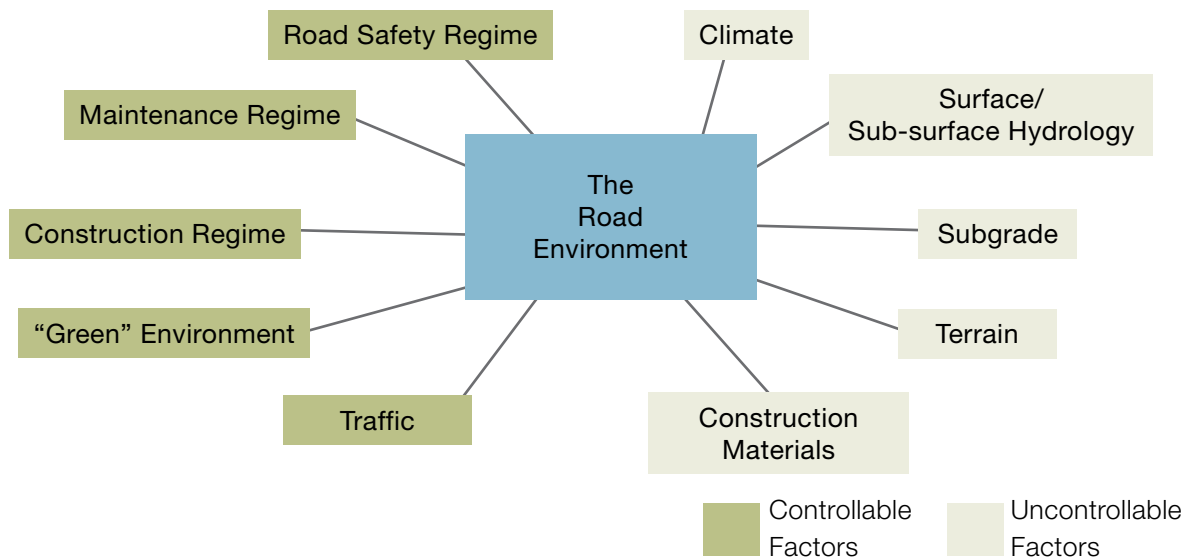

Figure 1-2: Road environment factors

The many road environment variables that affect the performance of LVSRs make it impossible to reduce their design to exact mathematical formulae based entirely on theory. The significant identifiable variables affecting the design of the pavement are:

- The nature of the materials to be used in pavement construction
- The detrimental effects of water on strength and stiffness
- The nature and volume of traffic
- Design, construction and maintenance provisions
- The funding climate, and the degree of acceptable risk

More than anything else, the management of moisture during the construction and during the performance phases of a LVSR pavement affects the eventual outcome, and it is clear that very great emphasis should be placed on this aspect of pavement design, construction and maintenance.

## 1.4 Environmentally Optimised Design

Invariably, the road environment factors encountered along a section of road will vary. In such a situation, in order to be as cost-effective as possible, it is necessary to ensure that the use of materials and pavement designs are matched to the road environment. This can be achieved by selecting different pavement options in response to different impacting factors along the road alignment, i.e. by adopting what is called an “environmentally optimised design” (EOD) approach. This approach is illustrated in Figure 1-3.

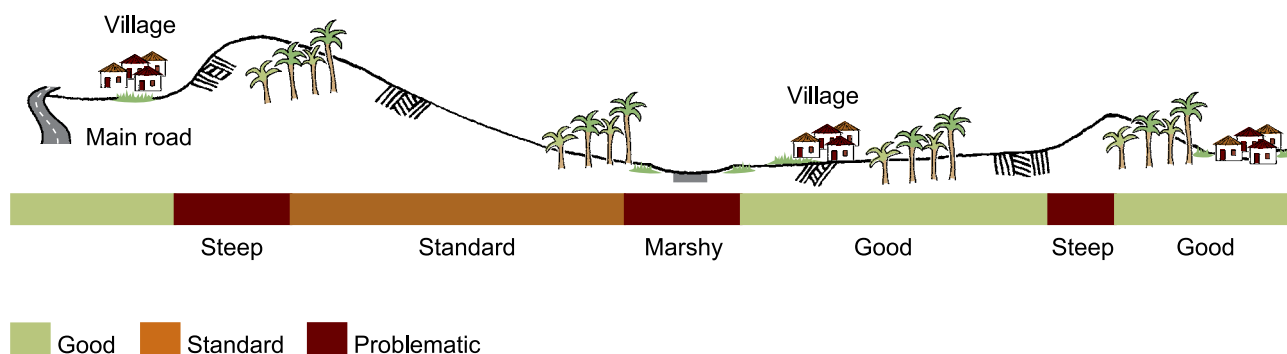

Figure 1-3: Application of the principle of environmentally optimised design

The EOD approach economises on deployed resources to achieve an acceptable level of service and results in the use of a spectrum of solutions ranging from a spot improvement through to the entire road length, in the process using appropriate pavement compositions, drainage systems and surfacings, including engineered natural surface (ENS), gravel, bituminous and non-bituminous surfaces.

## 1.5 Design Strategy

An appropriate design strategy needs to underpin the LVSR design philosophy enunciated above. In this regard, a number of strategic factors affecting the design of LVSR pavements must be decided at the planning stage in order to provide the necessary directive and inputs for these design process. These factors are discussed below.

## Design Life

The factors affecting the choice of the design life of a LVSR include:

- Functional importance of the road
- Traffic volume
- Location and terrain of the project
- Financial constraints
- Difficulty in forecasting traffic
- Maintenance philosophy and capability

It is normally more economical to use a relatively short design life for a LVSR particularly where design data reliability is low and accurate traffic estimates cannot be made. Table 3-1 in Part B provides guidance on the selection of the design life of a LVSR.

## Design Reliability and Risk

There are many reasons why it would be unreasonable to expect that a pavement design process can guarantee that a subsequently-constructed pavement will perform to design expectations. For example, the design values chosen for material properties are, at best, simplifications of their complex and variable properties within a constantly changing environment, particularly for natural gravels and soils which tend to be inherently variable. Thus, in any pavement design strategy, it is necessary to be aware of the main risk factors which could affect the performance of LVSRs so that appropriate measures can be taken to minimise them. These factors are summarised below:

- Quality of the materials (strength and moisture susceptibility)
- Construction control (primarily compaction standard)
- Environment (particularly drainage)
- Maintenance standards (drainage and surfacing)
- Traffic and overloading

The risk of premature failure will depend on the extent to which the above factors are negative – the greater the number of factors that are unsatisfactory, the greater the failure of risk. However, this risk can be greatly reduced by minimising material variability, ensuring that the construction quality is well controlled, that drainage measures are strictly implemented and maintenance is carried in a timely manner.

## 1.6 Surfacing Options

In view of the vulnerability of gravel roads to the effects of the road environment, some form of durable surfacing is required to protect the underlying natural gravel pavement structure. A wide range of surfacing options is available including both bituminous and non-bituminous types.

In keeping with the EOD approach described in Section 1.4, such surfacings may be provided for the entire length of the road, or only the most vulnerable sections. The approach may include dealing with only individual critical sections (weak or vulnerable sections; roads through villages or settlements) on a road link (spot improvements), or providing a total whole link design, which could comprise different design options along its length.

The choice of surfacing type, and when to use it, involves a trade-off between initial construction costs, level of service and maintenance requirements. This would entail the undertaking of a life-cycle analysis which is described in Chapter 6.

## 1.7 Context Sensitivity

In addition to ensuring that the design developed is technically appropriate to the prevailing road environment, there are a number of other factors that could influence the success of the LVSR design, its implementation and long-term sustainability. This requires a broadly focused, multi-dimensional and context sensitive approach in which a number of other influential factors are considered as illustrated in Figure 1-4.

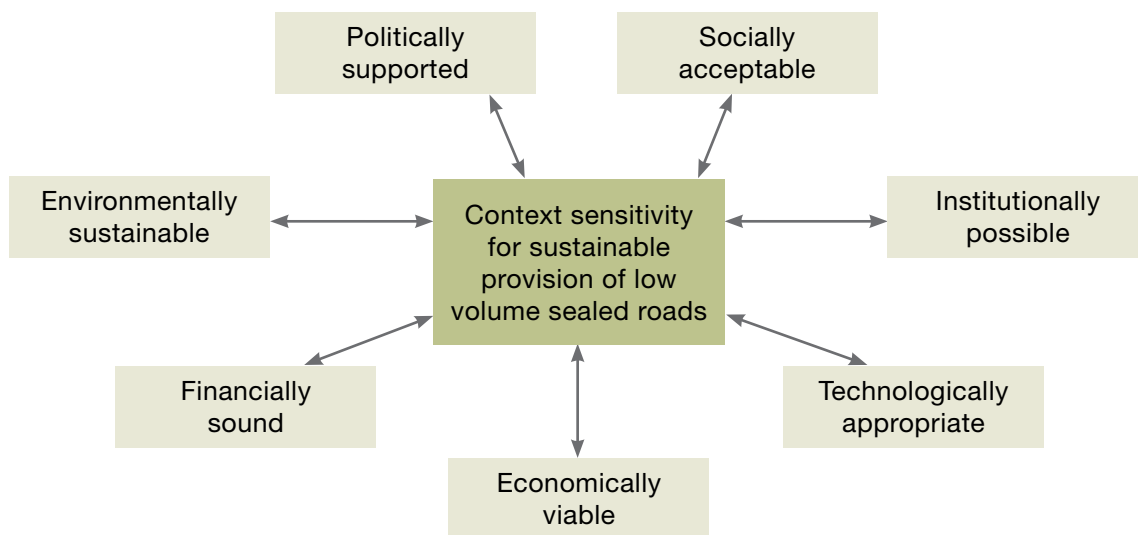

Figure 1-4: Framework for sustainable provision of LVSRs

### Political support

Demand for low volume road provision needs to be framed under a national policy driven by government and should be supported at the highest level. The cross-sectoral influence of low volume road provision and its role in under-pinning other sectoral development strategies and poverty alleviation programmes should be highlighted, quantified and understood.

The approach adopted for low volume road provision should complement national plans, policies and strategies and should be responsive to wider needs and demands, including:

- The social and economic goals of poverty alleviation and development
- Increasing rural accessibility
- The use of appropriate technology, promotion of the domestic construction industry and employment creation
- Protection of the environment
- Cost minimisation and improved efficiency

There is a need to maintain dialogue with political and public stakeholders in order to highlight the advantages of design approaches and alternative, often unfamiliar, solutions selected for low volume road provision and maintenance. The language used for advocacy should be carefully chosen and should avoid negative connotations such as “low standard”; “low cost” and “marginal”.

**Social acceptance**

Provision of low volume rural road networks should be managed in a way that:

- Ensures community participation in planning and decision making
- Eliminates gender bias and promotes participation by women in the road sector
- Promotes road safety in all aspects of low volume road provision
- Supports cost-effective labour-based and intermediate equipment methods of construction and maintenance
- Minimises resettlement and mitigates unavoidable resettlement through appropriate compensation

**Institutional capacity**

Road authorities and clients should:

- Promote institutional, economic and technical understanding in the provision and management of low volume roads
- Promote commercial management practices
- Develop a conducive environment for the development of national contractors
- Ensure that design, construction and maintenance approaches for low volume roads are represented on all tertiary civil engineering training curricula

**Technology choice**

Technologies for designing, constructing and maintaining low volume roads should:

- Employ appropriate design standards and specifications
- Utilise intermediate equipment technology options and reduce reliance on heavy equipment imports
- Promote road construction and maintenance technologies that create employment opportunities
- Use types of contract that support the development of domestic contractors and consultants
- Be robust to the vagaries of climate and recognise potential impacts of a changing climate

**Economic viability**

Economic appraisal for low volume roads should:

- Employ tools for low volume roads that are capable of quantifying social, economic and environmental costs and benefits
- Ensure investment decisions for low volume roads are based on an assessment of whole life costs

**Financially sound**

Sustainable provision of low volume roads depends on the sustainable provision of funding to the sector in that:

- Roads should not be upgraded to engineered standards if funding is not in place for routine and periodic maintenance requirements
- Designs should not be forwarded that require excessive allocation of maintenance resources

**Environmentally sustainable**

The design and management of low volume roads should:

- Minimise the physical impacts of construction and maintenance activities on the natural environment
- Take account of socio-cultural impacts (community cohesion)
- Minimise the carbon footprint
- Optimise resource management and allow for recycling of non-renewable materials
- Minimise impacts and emissions that might contribute to climate change

## Bibliography

1. Behrens L C (1999). **Overview of Low-Volume Roads: Keynote Address**. 7th Int. Conf. On Low-Volume Roads. Transportation Research Record No. 1652. TRB.
2. CAPSA (1989). **Cost Effective Low Volume Roads**. Workshop Session, 5th Conf. on Asphalt Pavements for Southern Africa, Swaziland, 1989.8th
3. Edmonds G A (1979). **Appropriate Technology for Low Volume Roads**. 2nd Int. Conf. on Low-Volume Roads. Transportation Research Record No. 702. TRB.
4. Kasakatira K (2010). **Low Volume Sealed Roads – The Malawi Experience**. 1st AFCAP Practitioners Conference, 23-25 November, 2010, Addis Ababa, Ethiopia.
5. Oglesky H O (1990). **Dilemmas in the Administration, Planning, Design, Construction and Maintenance of Low Volume Roads**. Transportation Research Special Report 160, TRB.
6. Parker N A (1997). **The Socio-Economics of Paving Low-Volume Roads**. Keynote Paper, 1.º Simpósio Internacional de Pavimentação de Rodovias de Baixo Volume de Tráfego, Rio de Janeiro, 5 a 10 de Outubro de 1997.
7. Pinard M I and Greening P A K (2004). **Sustainable Provision of Low-Volume Roads**, Conference on Asphalt Pavements for Southern Africa, Sun City, South Africa.

## 2. ENVIRONMENT

### 2.1 Introduction

A LVSR pavement must be able to function effectively within the environment in which it is to operate. This environment has to be accepted as it is and the design, construction and maintenance of the road must be suitably adapted.

A wide range of environmental factors can affect the design of pavements and need to be carefully considered in arriving at an optimum solution. For example, the prevailing climate will influence the supply (precipitation, water table), evaporation (temperature ranges and extremes) and movement of water in soils. These factors can affect the moisture content and strength of the road pavement, the selection of suitable materials, and the design of bituminous surfacings.

Following construction and particularly the sealing of the pavement, a new environment is created which can have a significant effect on the properties of the pavement materials and the underlying soil. The new environment is the result of superimposing on the natural environment, man-made factors such as new drainage conditions and surface properties (e.g. vegetated cover replaced by an impervious seal; introduction of new or removal of old trees and vegetation cover on or near the verges of the road and the road reserve, etc.)

Usually, the lighter the pavement (and traffic) the more pronounced the relative effect of the environment will be on the performance of the pavement. For such pavements, environmentally-induced rather than load-associated distress tends to determine the performance of such pavements. Thus, structural design procedures for relatively light trafficked pavements and surfacings need to take particular account of the stresses and strains caused by these environmental factors.

### 2.2 Climate

Malawi's climate is tropical continental and largely influenced by the huge water mass of Lake Malawi, which defines almost two-thirds of the country's eastern border. The climate ranges from semi-arid in the lower Shire valley, semi-arid to sub-humid on the plateaux and sub-humid in the highlands.

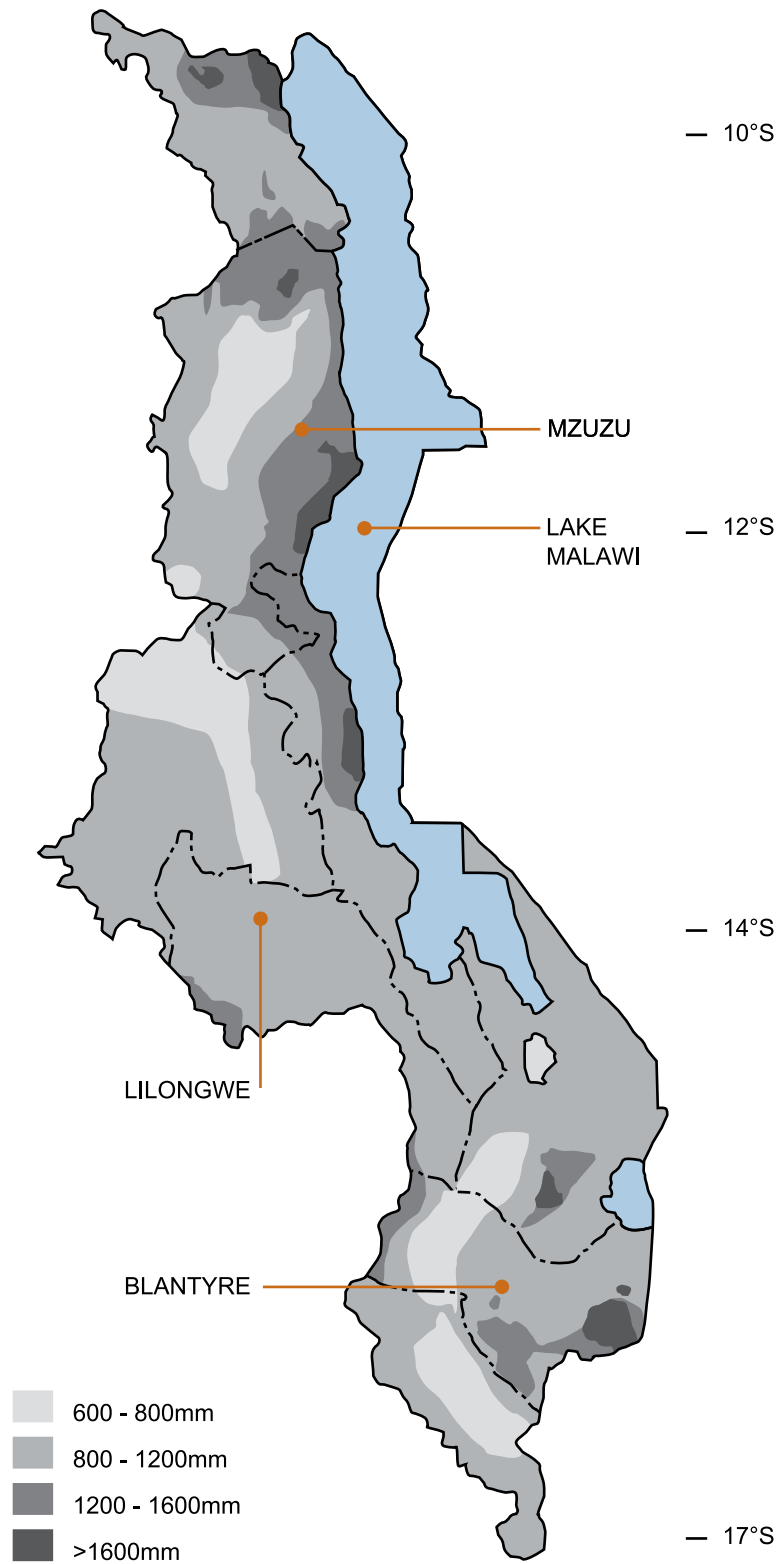

Figure 2-1: Distribution of rainfall in Malawi

## Rainfall

Annual rainfall ranges from 700 mm to 2400 mm with mean annual rainfall being 1180 mm. Its distribution is mostly influenced by the topography and proximity to Lake Malawi. The highest rainfall is experienced in the high altitude and mountainous areas of Mulanje, Zomba, Dedza and the plateaus of Viphya and Nyika whilst the lowest rainfall is experienced in the low lying areas of the Lower Shire Valley and other rain shadow areas. Almost 90% of rainfall occurs between December and March, with very little, if any, between May and October over most of the country.

In the higher rainfall areas of the country, surface runoff may be high leading to erosion of shoulders and side slopes, increased soil erosion, flash flooding and siltation of waterways from the disturbance of soil. Appropriate design measures must therefore be taken to combat the potential erosive impacts of high/intense rainfall on road performance as discussed in Part B, Chapter 8.



Severe erosion of road side slopes in high rainfall areas.

## Climatic zones

For pavement design purposes a country's climate can be divided into a number of zones (Table 3-1) based on the Weinert "N" value, a climatic index which is related primarily to the prevailing annual rainfall. This index (N value) correlates well with the macro climate, as well as the Thornthwaite Moisture Index  $I_m$  which gives an indication of the overall availability of moisture during the year.

**Table 2-1: Climatic zones: Approximate mean annual rainfall, N-Values and Thornthwaite**

Description	Typical Mean Annual Rainfall	Weinert N Value	Thornthwaite Moisture index ( $I_m$ )
Arid	< 250 mm	5+	< -40
Semi-arid	250 - 500 mm	4 - 5	-20 to -40
Sub-tropical	500 - 1000 mm	2 - 4	0 to +20
Humid tropical	> 1000 mm	< 2	+20 to +100

The Weinert N-values and climatic zones provide an important insight into the properties and engineering characteristics of naturally occurring materials that occur in Malawi. This facilitates a good understanding of the likely behaviour of these materials in particular climatic environments and allows practitioners to design and construct LVSRs with a greater degree of confidence in a wide range of circumstances.

### Weinert N-Value

The Weinert N-value is calculated from climatic data as follows:

$$N = \frac{12 \cdot E_j}{P_a}$$

Where  $E_j$  = evaporation during hottest month  
 $P_a$  = annual precipitation

## 2.3 Moisture Regime

The moisture regime in which a LVSR pavement must operate has a particularly significant impact on its performance due to the use of locally occurring unprocessed materials which tend to be relatively moisture sensitive. This places extra emphasis on drainage and moisture control for achieving satisfactory pavement life.

Each climatic zone will generally provide a different moisture regime which, other than in localised areas of micro climate, would be related to the Weinert N-value – the lower the N-value, the greater the availability of moisture during the year to wet up the pavement, and vice versa.

The various sources of moisture infiltration into a pavement are illustrated in Figure 2-2 and measures for dealing with them are discussed in Part B, Chapter 8 – Drainage.

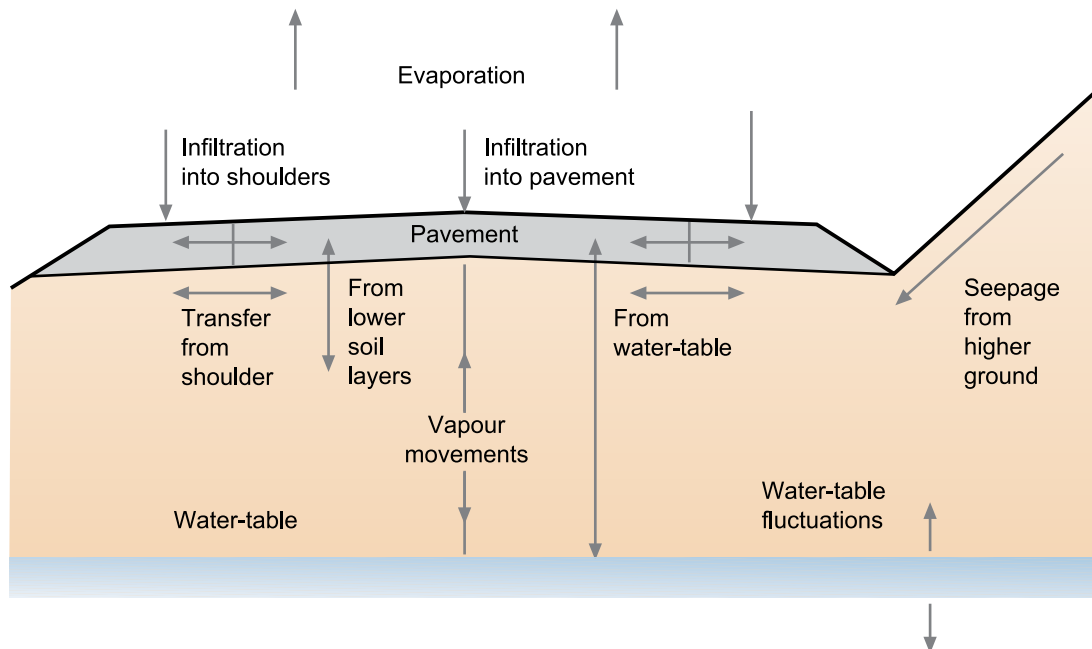

Figure 2-2: Moisture movements in pavements and subgrades

### Temperature

Mean annual temperatures vary with altitude, ranging from 25°C in the Lower Shire Valley to 13°C on the Nyika Plateau. Frost may occasionally occur in lower lying land on the plateau.

Temperature and solar radiation can both have significant implications on the performance of bituminous surfacings and should be taken into account in the surfacing design. This applies to the short term performance related to bleeding and loss of aggregate, and also the rate of binder ageing.

## Bibliography

1. Dickinson, E.J. (1981). ***Pavement temperature regimes in Australia: Their effect on the performance of bituminous constructions and their relationship with average climate indicators***. Special Report 23. Aust. Road Res. Board.
2. National Association of Australian State Road Authorities (NAASRA) (1984). ***Moisture Movements in Pavements and Subgrades***. NAASRA, Sydney.



## 3. MATERIALS

### 3.1 Introduction

Naturally occurring soils, gravel soil mixtures and gravels provide an important source of material for use in the construction of LVSRs. This is because these unprocessed materials are relatively cheap to exploit compared, for example, to processed materials such as crushed rock, and are often the only source of material within a reasonable haul distance of the road. Thus, in order to minimise LVSR construction costs, maximum use should be made of such materials. This is a central pillar of the LVSR design philosophy.

Traditional specifications tend to exclude the use of unprocessed materials in pavement layers in favour of more expensive processed materials because they often do not comply with traditional (HVR-orientated) requirements. However, research work carried out in Malawi and elsewhere in the Southern African region has shown quite clearly that such “non-standard” materials can often be used successfully and cost-effectively in LVSR pavements provided appropriate precautions are observed as discussed in this chapter.

The term “natural gravel” refers to a gravelly material occurring in nature, such as laterite, which can be produced without crushing. Some processing to remove or breakdown oversize may still be necessary. However, a distinction is made between these “natural” gravels and material produced from crushed hard rock and typically referred to as “crushed stone.”



As-dug, nodular laterite is a typical example of natural gravel that occurs extensively in Malawi. This material has been successfully used in the construction of LVSRs despite its non-compliance with traditional strength and plasticity requirements.

### 3.2 Materials Characteristics

Despite the innumerable influences that exist, there are some dominant materials characteristics that affect pavement performance which should be appreciated in order to design and construct LVSRs with reasonable confidence. These characteristics depend on whether the materials are used in an unbound or bound state which affects the manner in which they derive their strength in terms of the following intrinsic properties:

- Inter-particle friction
- Cohesive effects from fine particles
- Soil suction forces
- Physio-chemical (stabilisation) forces

The relative dependence of a material, and the influence of moisture, on each of the above components of shear strength will significantly influence the manner in which they can be incorporated within a pavement. In this regard, Table 3-1 summarises the typical relative characteristics of unbound and bound materials that critically affect the way in which they can be incorporated into a pavement in relation to their properties and the prevailing conditions of traffic, climate, economics and risk.

Table 3-1: Pavement material types and characteristics

Parameter	Pavement type			
	Unbound			Bound
	Unprocessed	Processed	Highly processed	Very highly processed
Material types	Category 1 As-dug gravel	Category 2 Screened gravel	Category 3 Crushed rock	Category 4 Stabilised gravel
Variability	High	Decreases		Low
Plastic Modulus	High	Decreases		Low
Development of shear strength	Cohesion and suction	Cohesion suction and some particle interlock	Particle interlock	Particle interlock and chemical bonding
Susceptibility to moisture	High	Decreases		Low
Design philosophy	Material strength maintained only in a dry state	Selection criteria reduces volume of moisture sensitive, soft and poorly graded gravels		Material strength maintained even in wetter state
Appropriate use	Low traffic loading in very dry environment	Traffic loading increases environment becomes wetter		High traffic loading in wetter environments
Cost	Low	Increases	High	High

Of particular significance to LVSRs

Unbound/unprocessed materials such as laterite are highly dependent on suction and cohesion forces for development of shear resistance which will only be generated at relatively low moisture contents. Consequently, special measures have to be taken to ensure that moisture ingress into the pavement is prevented (see Chapter 9), otherwise suction forces and shear strength will be reduced (see Figure below) which could result in failures. Illustrative soil strength/suction relationship

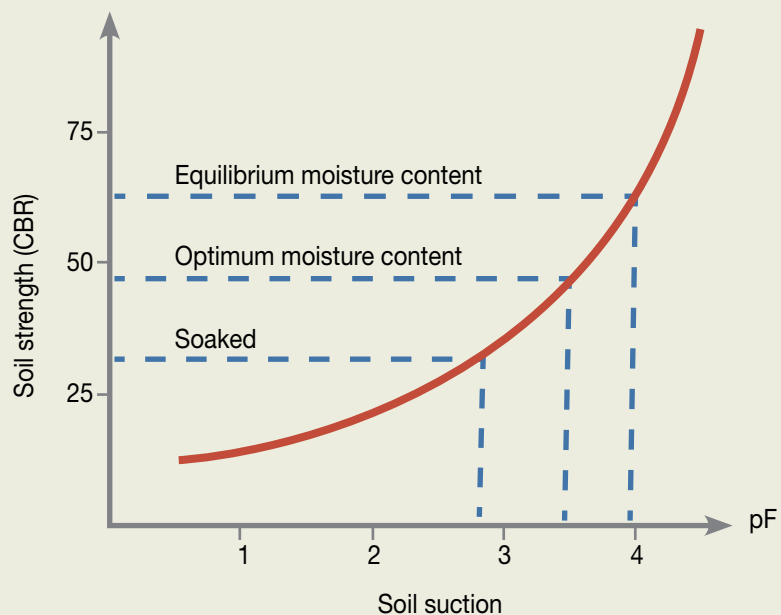

Figure 5-6: Illustrative soil strength/suction relationship

Since most LVSRs are constructed from unbound materials, a good knowledge of the performance characteristics of such materials is necessary for their successful use as discussed below:

- **Category 1 materials:** are highly dependent on soil suction and cohesive forces for development of shear resistance. The typical deficiency in hard, durable particles prevents reliance on inter-particle friction. Thus, even modest levels of moisture, typically approaching 60% saturation, may be enough to reduce confining forces sufficiently to cause distress and failure
- **Category 2 materials:** have a moderate dependency on all forms of shear resistance – friction, suction forces and cohesion. Because these materials have rather limited strength potential, concentrations of moisture, typically 60-80% saturation may be enough to reduce the strength contribution from suction or cohesion sufficiently to cause distress and failure. This would occur at moisture contents lower than those necessary to generate pore pressures
- **Category 3 materials:** have only minor dependency on suction and cohesion forces but have a much greater reliance on internal friction which is maximised when the aggregate is hard, durable and well graded. Very high levels of saturation, typically 80-100% will be necessary to cause distress and this will usually result from pore pressure effects

More than anything else, the management of moisture during the construction and operational phases of a pavement affects its performance, especially when unbound, unprocessed, generally relatively plastic materials are used. It is therefore very clear that emphasis should be placed on minimising the entry of moisture into a LVSR pavement so as to ensure that it operates as much as possible at an unsaturated moisture content. The beneficial effect of so doing is illustrated in Table 3-2 which shows the variation of a material's strength (CBR) with moisture content.

The FMC/OMC ratio is a significant contributory factor related to the performance of a LVSR. If, through effective drainage, the materials in the road pavement can be maintained at a moisture content that does not rise above OMC in the rainy season, then more extensive use can be made of local, relatively plastic materials that might otherwise not be suitable if they were to become soaked in service.

**Table 3-2: Variation of CBR with moisture content**

Laboratory Soaked CBR (%)	Laboratory Unsoaked CBR (%) at varying FMC/OMC Ratios <sup>1</sup>		
	105	150	200
80	105	150	200
65	95	135	185
45	80	115	165
30	65	95	140
15	45	70	110
10	35	60	100
7	30	50	85

### 3.3 Local Materials

There are a number of naturally occurring materials in Malawi which, although they may not meet the requirements traditionally specified for their use in the various layers of a road pavement are, nonetheless, “fit for purpose”. The most abundant of these materials include:

- **Laterite** - a precipitate of aluminium and ferrous oxides whose behaviour is largely dependent on the parent soil in which it is formed. Laterites that form in clayey soils tend to be plastic and this is very common. This is the major reason why they have not been widely recommended for road construction as the high plasticity leads to lower soaked CBRs and most therefore do not meet the traditional minimum base course CBR of 80%
- **Quartzite** – a product of the decomposition of igneous rocks with a large proportion of quartzite, often mixed with feldspar. Quartz gravel is very hard and may be angular or rounded. It is usually well graded and may have a high silt content depending on the composition of the parent rock. The material tends to be of relatively low plasticity and high strength making it suitable for construction of LVSR base courses in its natural state

Materials specifications are not always transferable from one region to another. What may be appropriate in one region, in relation to such factors as material type, climate and traffic loading, may well be quite inappropriate in another region where these factors may be quite different. In the final analysis, every material has its uses and limitations which must be matched to the traffic, climatic and other conditions influencing its performance. Costly failures in some cases, as well as over-conservative, uneconomic designs in others, can result when conventional materials specifications are rigidly applied with little regard to local conditions.

Conventional specifications are generally insensitive to the local road environment and tend to be applied in a blanket fashion irrespective of material type. This makes them generally inappropriate for application in tropical climates where the natural gravels behave differently to commonly used pavement materials in North America and Europe.

- **Decomposed granite** – formed from the decomposition of granitic rocks with a low content of quartz or silica. Decomposed granite gravels tend to have low plasticity and, regardless of the low particle strength, the material is potentially suitable for use as a basecourse on low volume roads

### 3.4 Specifications

Specifications are meant to exclude unsatisfactory materials for use in roads by placing limits on their various properties such as grading, plasticity and strength. The derivation of appropriate limits requires an intimate knowledge of the material's characteristics and their likely performance in a specific road environment, particularly climate and drainage measures, and for specific traffic loading. The challenge is to relate the material's physical properties with performance in a particular environment.

Until relatively recently, most of the specifications used in the Southern African region, including Malawi, tended to reflect temperate zone specifications emanating from Europe and North America. These “conventional” specifications rely heavily on experience related largely to “ideal” materials having the following properties:

- Restrictive grading requirements
- Low plasticity ( $PI < 6$ )
- High road base strength (soaked CBR  $> 80$  per cent at 98 per cent modified AASHTO compaction)

For LVSRs there is now a general recognition that there is a greater need to view the application of specifications in terms a “whole road environment”, rather than in terms of individual pavement layers. This provides scope in some cases to consider a reduction in standard when considering particular material types within defined environments. Recognising “fitness for purpose” is central to assessing the appropriate use of non-standard materials in LVSRs.

In setting specification limits, a clear distinction should be drawn between the following material types that occur in Malawi:

- **Natural gravels:** transported and residual soils and gravels such as alluvial sands, colluvial deposits and residual clayey sand deposits
- **Duricrusts (pedogenic materials):** indurated or partially indurated soils such as laterite, calcrete and silcrete

In general, whilst the use of conventional limits with natural gravels is often restrictive, for the reasons stated above, such limits can be even more restrictive when applied to pedogenic materials. The reasons for this are summarised below:

- These materials are not necessarily chemically inert and may be capable of self-stabilisation under the influence of wetting and drying cycles
- Where strength is inferred on the basis of grading, plasticity and/or laboratory CBR, the potential for self-stabilisation is not taken into account

In addition to the above, conventional specifications refer to the material in its compacted/laid state on the road. However, conflicts often arise between material acceptability as defined by the specification and material suitability in terms of its actual engineering performance as a road making material. This is particularly true when applied to laterites. These materials occur extensively in Malawi and have performed exceptionally well in a variety of road environments despite their gross non-compliance with conventional specifications.

### 3.5 Materials Selection

#### General selection criteria

The criteria used for selecting road materials for incorporation in a LVSR need to take account of their actual engineering purpose within the pavement. This requires consideration of the following factors:

- A knowledge of the key engineering properties of the material
- The task required of the material
- The governing road environment
- Future alterations to the road environment

#### Requirements for pavement materials

To perform satisfactorily, pavement materials, particularly in the base, must possess a number of attributes which must be satisfied with regard to their selection for LVSRs. These are presented in Table 3-3:

Table 3-3: Fundamental pavement material selection factors

<b>Strength</b>	Aggregate particles need to be resistant to any loads imposed during construction and the design life of the pavement.
<b>Mechanical stability</b>	The aggregate as a placed layer must have a mass mechanical interlocking stability sufficient to resist loads imposed during construction and the design life of the road.
<b>Durability</b>	Aggregate particles need to be resistant to mineralogical change and to physical breakdown due to any wetting and drying cycles imposed during construction or in service.
<b>Impermeability</b>	Impermeability of the base is generally desirable to prevent ingress of water.
<b>Haul distance</b>	Reserves must be within physically and economically feasible haulage distance.
<b>Placeability</b>	The material must be capable of being placed and compacted by the available plant.
<b>Environmental impact</b>	The material reserves must be capable of being won and hauled within any governing environmental impact regulations.

Both the mechanical stability and durability of a paved material are strongly correlated to its strength. Thus, strength is one of the most important parameters affecting the performance of a LVSR.

When very high moisture contents cannot be prevented, an open-graded permeable material may be advantageous to reduce the development of excess pore pressures.

Segregation of material within the base can be of concern, particularly if oversize material is permitted or if extensive water binding is used during compaction.

Attainment of the above selection factors would normally lead to the following key attributes of any pavement, namely:

- Adequate bearing capacity under any individual applied load
- Adequate bearing capacity to resist progressive failure under repeated individual loads
- The ability to retain that bearing capacity with time (durability)
- The ability to retain bearing capacity under various environmental influences which relates to material moisture content and, in turn, to climate, drainage and moisture regime

In light of the results emanating from research work carried out in Malawi and elsewhere in the Southern African region, the materials selected for LVSRs should be based primarily on (1) strength and (2) the strength/moisture/density relationship as discussed below.

- (1) **Strength:** The required strength is expressed in terms of the DCP design penetration rate (DN value) for the specific traffic. The DN value reflects the required in situ strength at the material at the expected in-service pavement moisture.
- (2) **The strength/density/moisture relationship:** A knowledge of the inter-relationship between the moisture, density and strength of a material can provide a critical insight into its properties and likely behaviour in the prevailing road environment. A laboratory investigation of this inter-relationship can be used to determine the sensitivity of the material's strength to both moisture and density and cognisance should be taken of these during the design and construction processes.

### 3.6 Materials Testing

Materials testing is normally prescribed in standards put out by various countries, of which the BS (British), ASTM (American) and TMH (South Africa), are in common use in the region. Unfortunately, these methods differ in many respects with regard to the actual test procedure and the method of testing. For example, authorities employing a BS Liquid Limit device will obtain a Plasticity Index (PI) on average 4 units higher than those using an ASTM Liquid Limit device.

It is important, therefore, not to mix testing standards because the differences in test procedure alone are sufficient to explain the difference in material quality apparently tolerable by pavements in different Southern African countries.

### 3.7 Materials Prospecting

Large quantities of natural gravel are required for constructing and maintaining LVSRs. It is therefore essential that optimum use is made of all materials available at the lowest possible cost. Very often, gravels occur as relatively small localised deposits, scattered around the landscape, and are usually overlain by a cover of soil and vegetation which makes it very difficult to find them. Consequently, modern exploration techniques must be employed to ensure that all available materials are located as efficiently as possible, instead of the “haphazard random” methods often used.



Example of a botanical indicator for locating calcrete – Snowbush (*Eriocephalus ericoides*).

The art of prospecting involves looking for clues as to the occurrence of useful materials and then digging to see what may be there. Learning to identify features that indicate the presence of gravel from interpretation of maps and other information is a key activity in prospecting. However, the most important parts are the desk study followed by the field survey and pit evaluation.

Information about gravels in the landscape typically comes from four main sources:

- Geological information from geological maps and reports
- Soils information from agricultural soils maps and reports
- Botanical indicators
- Landscape information from topographic maps, aerial photos and satellite images
- Other local information (e.g. existing borrow pits)

The above sources of information are analysed all together to assess the likelihood that gravel may occur at a particular place. A typical flow diagram for materials prospecting is shown in Figure 3-1.

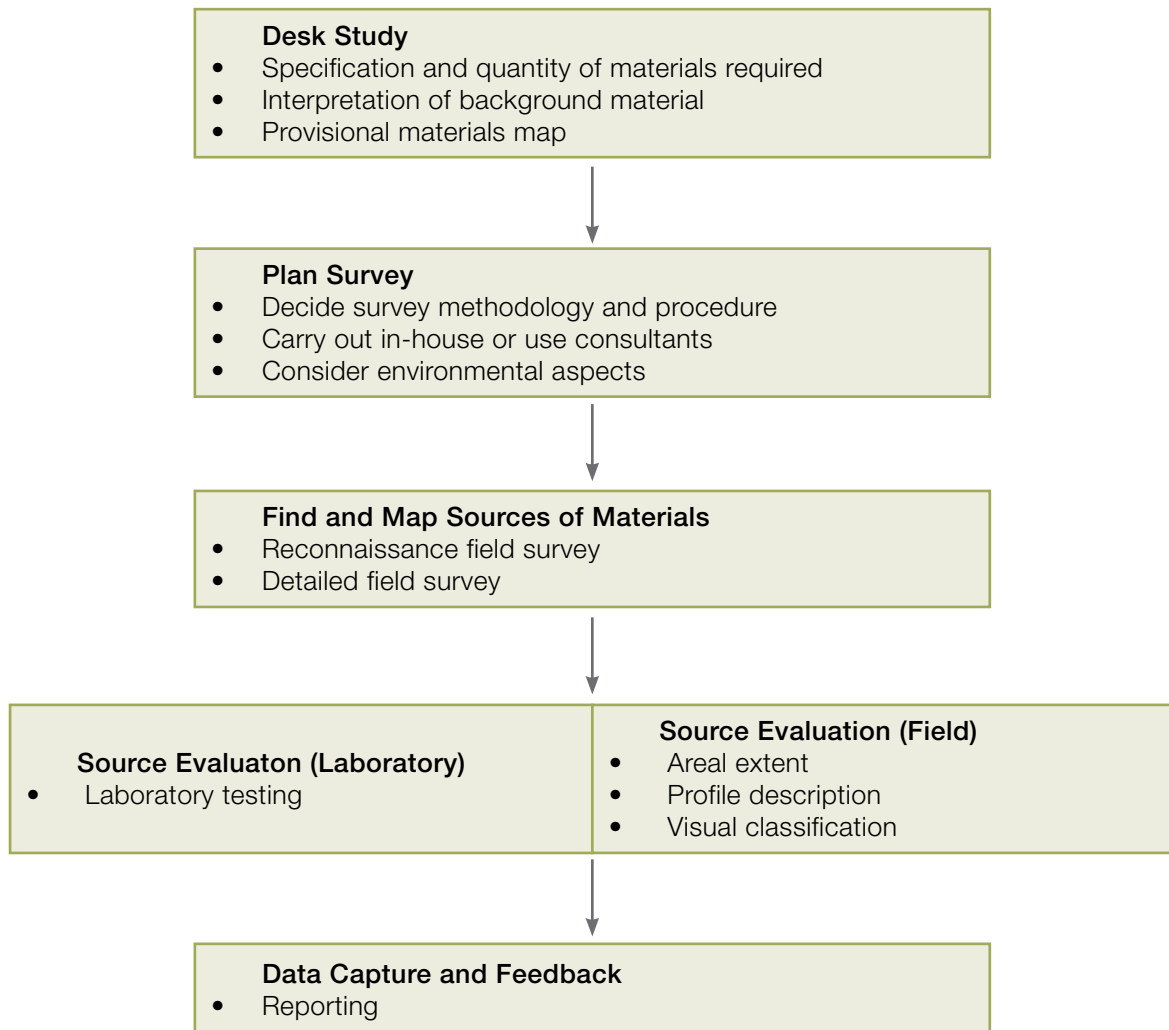

Figure 3-1: Flow diagram stages for materials prospecting

## Bibliography

1. Construction Industry Research and Information Association (1988). **Laterite in road construction pavements**. Special Publication 47. CIRIA, Westminster, London, UK.
2. Emery, S.J. (1992): **The Prediction of moisture content in untreated pavement layers and application to design in southern Africa**. CSIR Research Report 644, DRTT Bulletin 20, CSIR, Pretoria.
3. Grace, H and Toll, D G (1987). **Recent Investigations into the Use of Plastic Laterites as bases for Bituminous-Surfaced Low-Volume Roads**. Proc. Fourth Int. Conf. on Low-Volume Roads, Ithaca.
4. Gourley, C.S and P.A.K Greening. (1999). **Performance of Low Volume Sealed Roads: Results and Recommendations from Studies in Southern Africa**. TRL Published Report PR/OSC/167/99. Crowthorne.
5. McLennan, A K (1986). **Towards a strategy for the use of marginal and naturally occurring materials in pavements**. 24th ARRB Regional Symposium, Bundaberg, Queensland.
6. Metcalf, J B (1991). **Use of naturally occurring but non-standard materials in low-cost road construction**, Geotechnical and Geological Engineering, 9.
7. Mitchell, R L, van der Merwe C P and Geel, H K (1975). **Standardised Flexible Pavement Design for Rural Roads with Light to Medium Traffic**, Ministry of Roads and Road Traffic, Rhodesia Government.
8. Mitchell M F, Petzer, E C P and Van der Walt, N (1979). **The optimum use of natural materials for lightly trafficked roads in developing regions**. Transp. Res. Record 702.
9. National Association of Australian State Road Authorities. (1984). **Moisture movements in pavements and subgrades**. NAASRA, Sydney
10. Netterberg, F. and P. Paige-Green (1988): **Pavement materials for low volume roads in Southern Africa: A review**. Proceedings ATC Conference, Vol. 2B – Appropriate Materials and Methods. Pretoria.
11. Netterberg, F (1993) **Low-cost local road materials in southern Africa**. Geotechnical and Geological Engineering.
12. Paige-Green, P (1994). **Recommendations for the use of marginal base course materials in low volume roads in South Africa**, CSIR Transportek, Pretoria.
13. Roads Department, Ministry of Works, Transport and Communications, Botswana. (2000): **Methods and Procedures for Prospecting for Road Construction Materials**. Guideline No. 3.

14. Roughton International in association with The University of Birmingham and the University of Nottingham. (2000). ***Guidelines on Materials and Borrow Pit management for Low Cost Roads***. DFID, London.
15. Transport Research Laboratory (1993) ***Overseas Road Note 31. A guide to the structural design of bitumen-surfaced roads in tropical and sub-tropical climates (1993)***: Overseas Centre, TRL, Crowthorne, Berkshire, UK. (4th edition).
16. Weinhert H H (1980). ***The natural road construction materials of Southern Africa***. Pretoria: Academica.

## 4. PAVEMENT DESIGN

### 4.1 Introduction

The main objective of pavement design is to provide an economic, structurally balanced pavement structure, in terms of material types and thicknesses, that can withstand the expected traffic loading over a specified period of time (the chosen design life of the pavement), without deteriorating below a pre-determined level of service.

The load carrying capacity of the pavement is a function of both the thickness and stiffness of the materials used in the pavement layers and the support provided by the subgrade. Consequently, a good knowledge of the mechanical properties of the materials comprising the pavement layers and subgrade is important for designing the structure.

The outcome of the design process, in terms of the type and thickness of structure chosen, is influenced by the preceding planning phase and, in turn, determines many aspects of the subsequent construction and maintenance phases of road provision and management. Thus, in order to achieve a successful outcome, there is a need to ensure that the LVR design process is undertaken in a holistic manner and is based on a sound strategy that is related to the wide variety of design factors that are specific to the Malawian physical, social and economic environments.

#### Pavement structure and function

The principle function of the pavement layers (base and subbase) is to provide sufficient cover over the subgrade to limit the stresses and strains induced by wheel loading such that subgrade shear failures do not occur. The principle function of the surfacing is to keep the pavement dry and waterproof.

Figure 4-1 illustrates conceptually the way in which a pavement functions under loading. In essence, the wheel load,  $W$ , is transmitted to the pavement surface through the tyre at an approximately uniform vertical pressure,  $P_0$ . The pavement then spreads the wheel load to the subgrade so that the maximum pressure on the subgrade is only  $P_1$ . By proper selection of pavement materials and with adequate pavement thickness,  $P_1$  will be small enough to be easily supported by the subgrade.

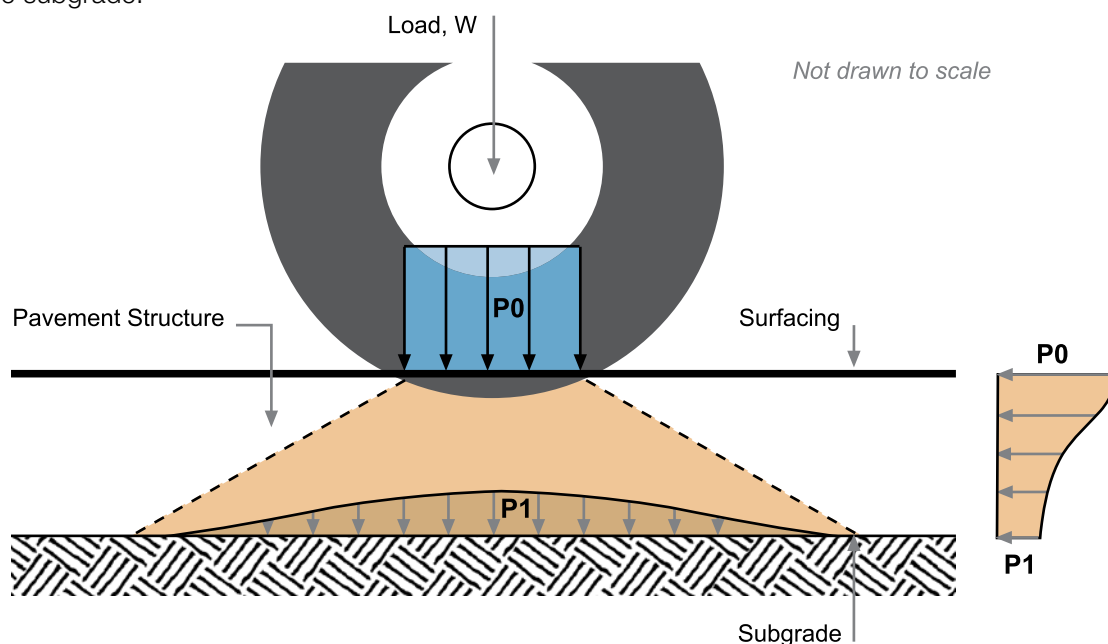

Figure 4-1: Wheel load transfer through pavement structure

Because of the different functions of the surfacing and pavement structure, these basic components of a road are often independent of one another and a large number of combinations are possible. However, in terms of the design of the overall road, some surfacings (e.g. surface treatment) do not contribute to the overall structural strength of the road, while others (e.g. penetration macadam) do. In the case of earth roads, the natural soil is the main structural component.

### **Pavement and surfacing options**

There is a wide range of pavement and surfacing options, both bituminous and non-bituminous, that can be used in various combinations in relation to the local environment and are well suited for incorporation in LVSR pavements (see Part B, chapter 7). These options allow maximum use to be made of locally available materials and minimum use to be made of more expensive high quality pavement materials, especially where they have to be processed or hauled long distances.

## **4.2 Pavement Design Methods**

### **4.2.1 Alternative design methods**

There are a number of design methods that may be used for the design of road pavements including the following:

- CBR Cover Curve method
- AASHTO Structural Number method
- Mechanistic-empirical design method
- Catalogue method

The above methods all vary with regard to their complexity in terms of the input parameters required to undertake the design process. In general, the more complex methods, such as the theoretically based Mechanistic-empirical design method, are unsuitable for use with low volume roads due to their underlying assumptions that do not apply to the materials that are typically used to construct such roads.

Design catalogues are the easiest design process to use as all the practical and theoretical work has been carried out and different structures are presented in catalogue form for various combinations of traffic, environmental effects, pavement materials and design options. These catalogues have typically been based on accelerated testing (e.g. the South African TRH4 design method and the Dynamic Cone Penetrometer (DCP) design method) whilst others have been based on the results of full-scale experiments where all factors affecting performance have been accurately measured and their variability quantified (e.g. the UK Overseas road Note 31).

### **4.2.2 Design methods for LVRs**

Pavement design for low volume roads presents a particular challenge to designers. This is largely because, until relatively recently, such roads were not specifically catered for by the traditional design methods and the step from an unsealed gravel road to a sealed road was a large one. Moreover, pavement engineers are required to carefully consider the environment within which LVRs have to be provided in a manner which is often much more demanding than with high volume roads.

The primary, empirically-based, pavement design methods that are best suited for the design of LVR pavements are:

- The CBR catalogue design method
- The Dynamic Cone Penetrometer (DCP) catalogue method

Both the CBR and DCP pavement component (layer by layer) analysis methods are empirically derived based on material shear strength and can only be accurate if used for the evaluation and analysis of pavements similar to those for which they were derived. However, the DCP method is much further developed and more advanced than the CBR method, allowing for detailed evaluation and analysis of the pavement structure to an effective depth of 800 mm and incorporating concepts such as “pavement strength balance” which influence the load sensitivity of the pavement. The outline characteristics of the CBR and DCP methods of design are outlined below.

### 4.2.3 CBR Catalogue design method

The CBR catalogue design method relies on the laboratory CBR method for determining the strength of the in situ and pavement materials. The applicability of the CBR test to materials selection and pavement design, particularly for LVSRs, has been questioned for a number of reasons, including:

- 1) Very poor repeatability and reproducibility of CBR results with an overall coefficient of variation of the order of 20-25%.
- 2) The test was designed as an indicator test for soils; it is not a performance-related test which explains the frequent anomalous behaviour of road pavements constructed with materials of low CBRs.
- 3) Although the test is used as an indicator test for material selection, materials ranked in the soaked condition do not necessarily rank in the same order at the moisture contents prevalent in the road pavement.

For a true mean value of 80, the CBR can range from 48 to 112, a range that can lead to vastly differing interpretations of the suitability of the soil for use in the pavement structure.

The SADC/TRL design guide (Performance of Low-Volume Sealed Roads: Results and Recommendations from Studies in Southern Africa) has been developed for the design of LVSRs but is based on the traditional CBR approach.

### 4.2.4 DCP catalogue design method

The DCP method uses in situ and laboratory measurements of an empirically defined material property, resistance to penetration, or DN value, to evaluate pavement behaviour. The relationship between DN value, pavement composition, traffic loading and minimum cover requirements are used to evaluate the structural requirements suitable for a specific traffic loading and to design an adequate pavement structure.

Based on Heavy Vehicle Simulator (HVS) full scale testing of 57 sections of low volume roads, an evaluation was made of various types of low volume roads located in a variety of road environments. Such testing revealed that most deformation occurred in the upper 200 mm of the pavements, and not in the subgrade. Thus, pavement behaviour of LVSRs is generally evaluated in terms of deformation originating in the upper layers of the pavement due to inadequate shear strength of the pavement materials and not due to deformation originating in the subgrade for which a compressive strain criterion would need to be satisfied.

The main characteristics of the DCP design method are summarised in Table 4-2.

Table 4-2: Main characteristics of DCP design method

Situation	Manifestation of Distress	Cause/ Mechanism of distress	Design Approach	Principal Design Inputs	Secondary Design Inputs
Distressed pavements with thin surfacings and granular sub-layers	Shear Deformation (20 mm rut depth)	Shear of material in base/subbase (upper 200 mm)	Pavement Component Analysis – DCP measurements (empirical approach with emphasis on pavement balance and minimum material properties)	Structural evaluation: - DCP measurements (DN values)  Traffic Environment  Moisture regime	- Layer strength diagram(LSD) - Pavement strength balance Design traffic (MESA)  Required pavement structure - Layer thickness - Layer design properties (min. requirements)

The reliability of the use of empirically derived component analysis design methods, such as the DCP design method, depends strongly on whether the method is applicable for use on a specific pavement. In this regard, the pavement needs to have a reasonably well-balanced structure. This has been found to be typically the case with natural gravel pavements that have undergone “traffic moulding or re-moulding” whereby compaction under traffic loading coupled with environmental changes (wetting and drying cycles), cause the pavement structure to attain a strength profile that exhibits a relatively smooth decrease in strength with increasing depth, i.e. a relatively well-balanced pavement structure.

Because of the empirical nature of the DCP method, it should be applied in a multi-analysis approach including visual surveys and test pit information. Moreover, the applicability of the method should be thoroughly investigated before application. Nevertheless, when found applicable the DCP method has been found to provide an easy to use and reliable procedure to determine the upgrading requirements of unsealed roads.

#### 4.2.5 Application of the DCP design method

The DCP method is useful where a basic or more developed pavement structure is already in place and needs to be enhanced or upgraded. Such upgrading is best accomplished by maximising the use of the in situ materials and conditions. Over the years and under traffic, unsealed roads achieve a significant degree of subgrade compaction, localised weak areas tend to become strengthened and an accumulation of residual gravel wearing course provides a sound support or foundation for the new paved road. Optimising the use of these conditions usually results in a reduction in the need to import large quantities of virgin material.

Notwithstanding the above, the DCP method can also be used for the design of new roads (where no previous gravel road existed) and the rehabilitation of existing paved road. However, whilst the principles of the method remain substantially the same as for upgrading gravel roads to a paved standard, the procedures differ somewhat and are not the subject of this manual.

One of the major advantages of using a DCP is that the pavement is tested in the condition reasonably representative of the conditions at which it performs. The simplicity of the test allows repeated testing to minimise errors and also to account for temporal effects. Sound engineering judgment and understanding as well as knowledge of the specific site are necessary to maximise the information that can be obtained from a DCP profile.

In principle, the DCP method can also be used for the design of earth/sand roads for which the procedure would be similar to that for gravel roads. However, because of the less substantial nature of the in situ pavement, the construction process would be different in that there may be need for initial compaction of the roadbed before undertaking the DCP survey to establish the overlying pavement layer requirements.

## Bibliography

1. Committee of State Road Authorities (1996). ***Structural design of flexible pavements for interurban and rural roads***. Pretoria: department of Transport. Technical Recommendations for Highways (TRH4).
2. Kleyn, E G and van Zyl G D (1988). ***Application of the DCP to Light Pavement Design***. First Int. Symposium on Penetration testing, Orlando, USA.
3. Kleyn, E G (1982). ***Aspects of pavement evaluation and design as determined with the aid of the Dynamic Cone Penetrometer (DCP)***. M.Eng. Thesis, University of Pretoria, Pretoria.
4. Mitchell, R L, van der Merwe C P and Geel, H K (1975). ***Standardised Flexible Pavement Design for Rural Roads with Light to Medium Traffic***, Ministry of Roads and Road Traffic, Rhodesia Government.
5. Transport Research Laboratory (1993). ***Overseas Road Note 31. A guide to the structural design of bitumen-surfaced roads in tropical and sub-tropical climates (1993)***: Overseas Centre, TRL, Crowthorne, Berkshire, UK. (4th edition).
6. Transport Research Laboratory (1993). ***Measuring Road pavement Strength and Designing Low Volume Sealed Roads Using the Dynamic Cone Penetrometer***. Unpublished Project Report UPR/IE/76/06. Project Record No. R7783.
7. Van der Merwe, C.P. (1999). ***Material and Pavement Structures for Low Volume Roads in Zimbabwe***. Unpublished Report, Harare.
8. Wolff H, Emery, S J, van Zyl, G D and Paige-Green, P (1995). ***Design Catalogue for Low-Volume Roads Developed for South African Conditions***. Proc. Sixth Int. Conf. on Low-Volume Roads, Proc. Sixth Int. Conf. on Low-Volume Roads, Minneapolis, Minnesota, June 25-29, 1995.

## 5. PRACTICAL CONSIDERATIONS

### 5.1 Introduction

There are a number of practical considerations that may influence the final design of a LVSR that have not been specifically addressed in previous chapters of this manual. These include:

- Problem soils
- Construction issues
- Vehicle overloading
- Maintenance issues
- Road safety issues

Some of the key factors that need to be taken into account in addressing the practical considerations listed above are discussed below.

### 5.2 Problem Soils

By virtue of their unfavourable properties for road construction, a number of subgrade soils fall into the category of “problem soils” and, when encountered, would normally require special treatment before acceptance in the pavement foundation. In Malawi, the following types of problem soils merit special consideration:

- Expansive clays
- Micaceous soils
- Low-strength soils

#### Performance risk

In assessing the appropriateness of the measures available for dealing with problem soils, a careful balance has to be struck between the cost of the measures and the benefits to be derived. This would require that a life-cycle analysis be carried out to determine whether the costs of the measures would be at least off- set by the benefits. Bearing in mind the relatively small user benefits generated by LVSRs when compared with higher trafficked roads, it is unlikely that the more extensive and costly measures would be justified.

#### Expansive soils

Expansive soils are those which exhibit particularly large volumetric changes (swell and shrinkage) following variations in moisture contents. The mechanism of expansion illustrated in Figure 5-1 is that of seasonal wetting and drying, with consequent movement of the water table. Soils at the edge of the road wet up and dry out at a different rate than do those under a paved surface, thus bringing about differential movement. It is this movement rather than the low soil strength (most expansive soils are often relatively strong at their equilibrium moisture content) which brings about failure. Such failure typically takes the form of associated longitudinal crack development,



Expansive “black cotton” soil exhibiting wide-spaced shrinkage



Typical longitudinal cracking and pavement deformation caused by large volumetric changes of an expansive soil subgrade.

occurring first in the shoulder area and developing subsequently in the carriageway, as well as general unevenness of the pavement surface, arcuate cracking and settlement near trees and transverse humps and cracks at culvert sites.

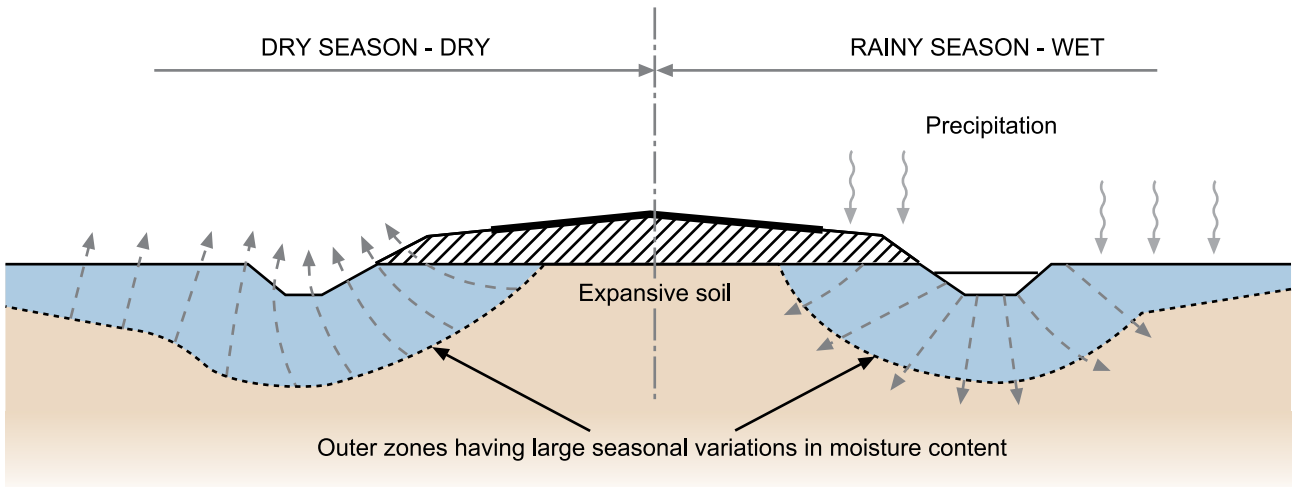

Figure 5-1: Moisture movements in expansive soils under a paved road

The chosen measures to minimise or eliminate the effects of expansive soils for LVSRs will depend on their degree of expansiveness. This property may be determined from the relationship between the Plasticity Index (PI) and clay content of the soil as illustrated in Figure 5-2 (Note: the PI is measured on the material passing the 0.425 mm sieve).

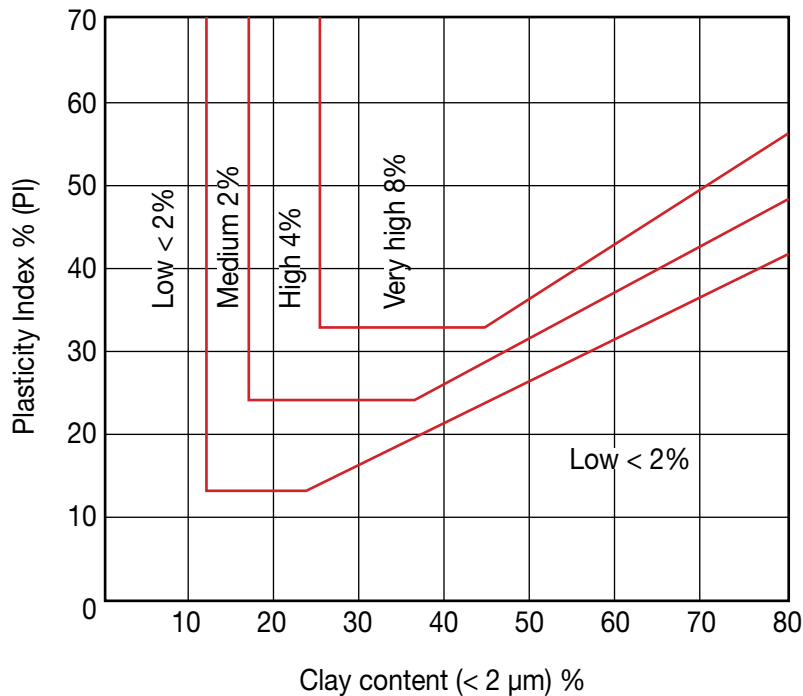

Figure 5-2: Determination of soil expansiveness (Modified Van de Merwe Chart)

The measures for dealing with expansive soils need to be economically realistic and proportionate to the risk of potential pavement damage and increased maintenance and user costs. Typical measures include:

- Acceptance of problem and strategy to re-work and re-seal e.g. after 10 years
- Realignment, where possible
- Excavation and replacement
- Chemical treatment
- Minimising moisture changes
  - wide (at least 2 m), sealed shoulders
  - avoidance of side drains
  - gentle side slopes (1:6 or flatter)
  - minimum earthworks cover 0.6 m

The measures for dealing with expansive soils need to be economically realistic and proportionate to the risk of potential pavement damage and increased maintenance and user costs. Typical measures include:

- Acceptance of problem and strategy to re-work and re-seal e.g. after 10 years
- Realignment, where possible
- Excavation and replacement
- Chemical treatment
- Minimising moisture changes
- Wide (at least 2 m), sealed shoulders
- Avoidance of side drains
- Gentle side slopes (1:6 or flatter)
- Minimum earthworks cover 0.6 m

### **Micaceous soils**

Micaceous soils contain large quantities of mica (muscovite) and occur in such materials as weathered granite, gneiss, mica schist and phyllite – materials that occur in various areas of Malawi. These soils often cause problems with compaction because of the “spring action” of the muscovite materials which may prevent achievement of the intended density or, even if it is achieved initially, can cause rutting in the compacted layer at a later stage.

Methods for dealing with micaceous soils include:

- Removing the micaceous soil layer to below the material depth in the subgrade
- Stabilising the micaceous soil with lime or cement

For LVSRs, the loss of shape associated with micaceous subgrades would generally have to be accepted unless the overlying pavement warrants the expense of the countermeasures indicated above.

### **Low-strength Soils**

Soils with a soaked CBR of less than 3 per cent (< 2 per cent in dry climates) are described as Low-Strength soils. These soils may be extremely soft in their natural state or become extremely

soft on soaking. They occur particularly in the low-lying, swampy areas of Malawi. They are easy to identify either in situ or during site inspections or laboratory testing of their soaked strengths. Typical treatment measures for such soils include:

- Removal and replacement with suitable material
- Stabilisation – chemical, modification with lime or mechanical
- Use of geo-synthetic products
- Raising of vertical alignment to increase soil cover

Further details on the respective methods of treatment for low-strength soils need to be established in the design stage at project level and the appropriate measure will depend on soil properties, site conditions, available equipment, available materials, experience from other sites with similar conditions and construction economy.

### 5.3 Construction Issues

One of the challenges of utilising natural gravels in LVR pavements is to maximise their strength, increase their stiffness and bearing capacity, increase their resistance to permanent (plastic) deformation and reduce their permeability (and, hence, susceptibility to moisture ingress). These attributes can be achieved through effective compaction, as discussed below.

Effective compaction of the existing running surface of the gravel road which is to be upgraded is one of the most cost-effective means of improving the structural capacity of the LVSR pavement. A well compacted running surface (effectively and typically the subbase of the new pavement) possesses enhanced strength, stiffness and bearing capacity, is more resistant to moisture penetration and less susceptible to differential settlement. The higher the density, the stronger the layer support, the lesser the thickness of the overlying pavement layers and the more economic the pavement structure. Thus, there is every benefit to achieving as high a density and related strength as economically possible in the subgrade.

Maximising the strength potential of a subgrade soil can be achieved, not necessarily by compacting to a pre-determined relative compaction level, as is traditionally done but, rather, **by compacting to the highest uniform level of density possible (“compaction to near refusal”) without significant strength degradation of the particles**. In so doing, there is a significant, beneficial, gain in density, strength and stiffness and reduction in permeability, the benefits of which generally outweigh the costs of the additional passes of the roller.

Compaction to near refusal ensures that the soil has been compacted at an appropriate moisture content to its near elastic state as shown in Figure 5.3 at which point the air voids in the material are relatively low (< 5%) with the significant benefit of reduced pavement deflection and increase in pavement life as illustrated in Figure 5.4. If, however, the volume of voids is high after construction, the pavement will densify under traffic loading and rutting will appear in the wheel tracks. Further, if both the moisture content is high in service and the air voids are also high, the pavement is potentially unstable and serious deformation is likely to occur, particularly with heavy traffic using the road. These potentially adverse situations emphasise the importance of ensuring that the subgrade compaction is carried out properly by controlling both the air voids and moisture content at which the specified density is attained.

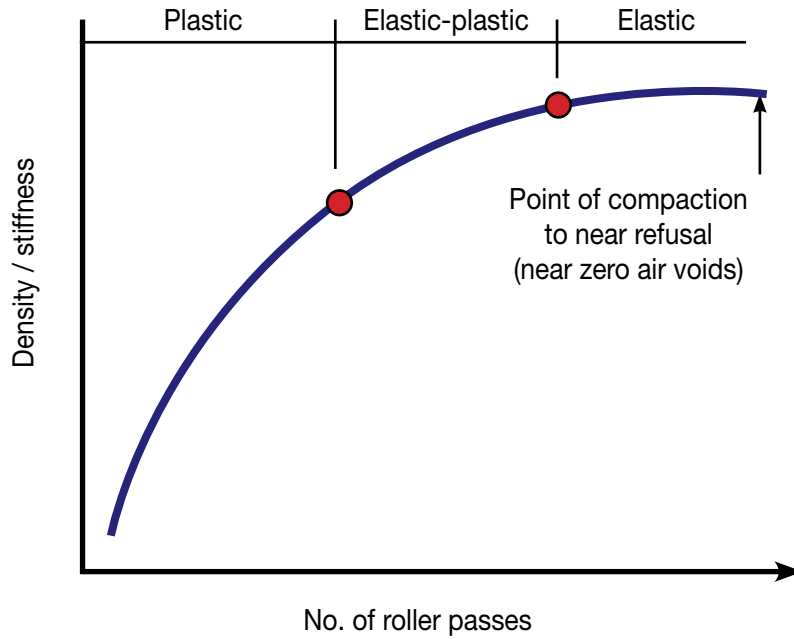

Figure 5-3: Illustration of concept of “compaction to refusal”

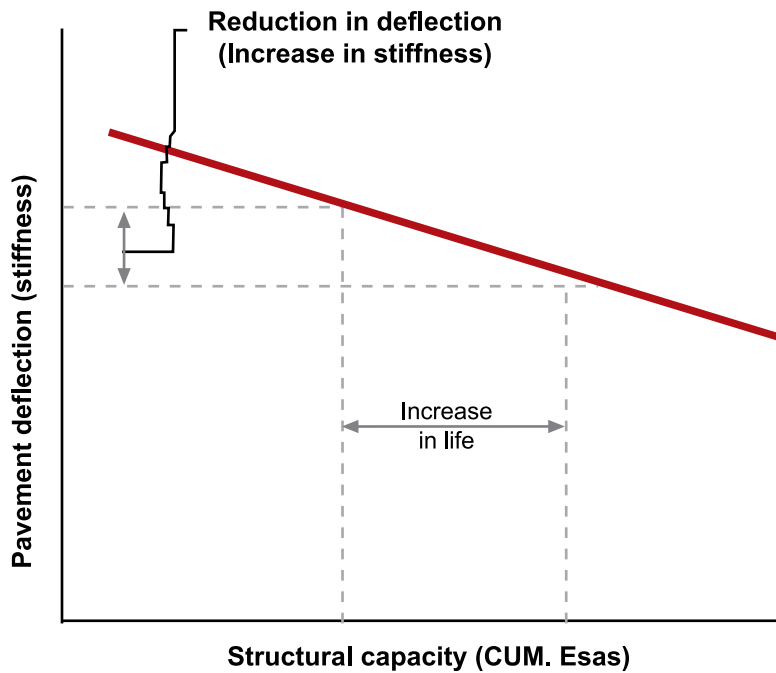

Figure 5-4: Deflection-life relationship showing benefits of “compaction to refusal”

Table 5-1 gives the minimum compaction requirements for the various layers in the pavement. For the reasons stated above, where the higher densities can be realistically attained in the field (compaction to near refusal) from field measurements on similar materials or other established information, they should be specified in the tender documents.

Table 5-1: Minimum compaction requirements

Pavement Layer	Material Class	Target Density (Relative compaction)
Base	NG80	98-100% BS Heavy
	NG65	
	NG45	
	NG30	
Subbase/Subgrade	NG15	95-98% BS Heavy
	NG10	
	NG7	

### Quality Attainment

LVR design procedures assume that both the material properties and levels of density specified are achieved in the field. However, in order to attain the specified densities, it is essential to ensure, as far as practicable, the uniform application of water, the uniformity of mixing and uniformity of compaction at or near OMC.

It is also important to note that layers below the one being compacted should be of sufficient density and strength to facilitate effective compaction of the upper layer(s). Adherence to the compaction recommendations given in Table 5-1 should ensure this.

Whilst it is necessary for natural gravels to be brought to OMC for efficient compaction, it is necessary to ensure that premature sealing does not lock in construction moisture. This can be achieved by allowing a significant amount of drying out to occur before sealing takes place, typically to 50% of OMC, particularly for materials that rely on soil suction forces for strength gain and improved stability.

The variability of natural gravels is a significant factor in the reliability of performance of the pavement. However, various measures can be taken during construction to reduce such variability. These include:

- **Careful selection during the winning process.** Physical properties of natural gravels in most deposits tend to change with depth and location. Careful selection of the material during the winning process, coupled with appropriate testing on a grid pattern (e.g. use of the linear shrinkage test) will often facilitate uniform stockpiling of the material. Mixing of materials in the borrow pit before stockpiling will also assist with uniformity, provided poor materials are removed beforehand
- **Processing of stockpiled material:** Power screens have proved effective in screening out and blending in to overcome deficiencies and can be particularly useful in attaining the requirements for gravel wearing course materials
- **Quality control and assurance:** Quality attainment and control are paramount when using unprocessed materials for LVR construction. Quality assurance procedures and the use of statistical control methods are recommended. Such measures will eliminate the costly ramifications flowing from arbitrary decisions to include or exclude the use of certain readily available materials

## 5.4 Vehicle Overloading

Incidences of vehicle overloading can have a significant negative impact on the performance of a LVSR. Figure 5.5 illustrates the adverse impact of overloading on a road pavement and the consequent need for unnecessarily high maintenance and rehabilitation costs.

The effects of overloading are observed especially by premature failures of surfacing layers (excessive rutting, bleeding, loss of surface texture, and ravelling being prevalent as early indicators). Naturally, every effort should be made to limit the amount of overloading (illegal loading) but it is recognised that current controls may not always be sufficient.

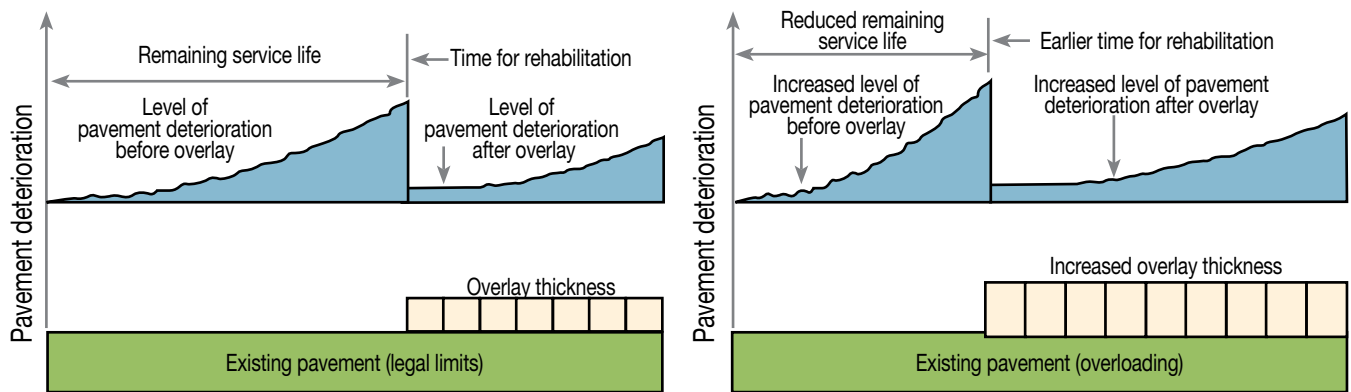

Figure 5-5: Impact of overloading on pavement performance

While the design process should account for the amount of heavy vehicle axle loads in determining the design traffic loading (Chapter 6), the specific effects of the very heavy abnormal axle loads on the pavement must be considered in finalising the design.

In situations where overloading is likely to occur, special attention must be given to the quality and strength of all the pavement layers during construction. Amongst other measures, there may be justification in adopting a higher traffic design loading which will result in the need for increased quality and thickness of the base and subbase/subgrade layers. The specific measures that the Engineer may deem necessary should, ideally, be based on either proven local practice or at least specialised advice/analysis in order to maintain a well balanced structure.

## 5.5 Maintenance Issues

The case for maintenance is a compelling one. Having spent time, effort and money in planning, designing and constructing a LVSR, it is vital to ensure that the asset is preserved by timely and effective maintenance in order to:

- Prolong the life of the road and postpones the day when renewal will be required
- Reduce the cost of operating vehicles on roads; and
- Help to keep roads open and enable greater regularity, punctuality and safety of road transport services

Road maintenance seeks to conserve as nearly as possible, the original designed condition of a road in a manner most likely to minimise the total cost to society of vehicle operation and accident cost, plus the cost of providing the maintenance itself, under the constraints of severe resource limitations.

The following routine and periodic maintenance activities, which may be of either a *cyclic* or *reactive* nature, are essential to the preservation of LVSRs.

**Table 5-2: Maintenance activities**

Works Category	Maintenance Activity	Type	
		Cyclic	Reactive
Routine Maintenance	<i>General:</i>		
	Grass cutting	x	
	Removal of obstacles		x
	Culvert clearing/repair		x
	Bridge clearing/repair	x	
	Drain clearing	x	
	Erosion control/repair		x
	Carriageway markings		x
Repairing road signs		x	
Recurrent Maintenance	<i>Pavement:</i>		
	Pothole repairs		x
	Surface patching (local sealing)		x
	Crack sealing		x
Edge repairs		x	
Periodic Maintenance	Rejuvenation seal		x
	Resealing	x	
	Shoulder regravelling/reshaping		x

**Routine maintenance:**  
fixed cost activities that are carried out irrespective of the engineering characteristics of the road or the density of traffic (e.g. grass cutting).

**Recurrent maintenance:**  
activities required throughout the year but whose frequencies vary with traffic, topography and climate (e.g. road marking).

**Periodic maintenance:**  
those recurrent activities that are required at intervals of several years (e.g. resealing).

Many of the activities listed in Table 5-2 can be carried out cost-effectively using labour-based methods. If some of the routine maintenance work is contracted on a “lengthmen contract” basis, for example, there would be little or no requirement for maintenance labour camps for transport to and from the work site, thereby saving money. Some periodic maintenance work may still require specialised equipment, e.g. bitumen sealing operations, but labour-based methods can be used for many activities.

In view of the moisture sensitive nature of the naturally occurring, unprocessed materials that are typically used in the construction of LVSRs, they will present a more demanding challenge than more heavily trafficked HVSRs for their proper maintenance. Thus, in order to avoid their untimely deterioration, maintenance must be scheduled and carried out more frequently and expeditiously than for HVSRs. Failure to do so can result in the loss of a LVSR more quickly than a HVSR. It is therefore essential that the routine and periodic activities maintenance activities listed in Table 5-2 are carried out timeously.

### Maintenance Activities Prior to Upgrading

Any maintenance activities for a gravel road which is planned to be upgraded to a sealed standard should be carried out just prior to the to the upgrading works. Such works would typically include the following, where required:

- Drainage improvements (see Part B, Chapter 8)

- Embankment raising (see Part B, Chapter 8)
- Reshaping/gravelling works (see Part C, Chapter 5, Section 5.3)
- Other miscellaneous works associated with the road upgrading

The above approach will ensure that scarce resources are used as efficiently as possible and any expenditure on maintenance will be full preserved by the road upgrading to a LVSR standard.



Grass cutting—a typical, labour-based routine maintenance activity.

## 5.6 Road Safety Issues

Road safety is of primary importance for all road users in Malawi whether they are travelling on LVSRs or more highly trafficked trunk roads. There appears to be no statistical evidence to indicate that accident rates on LVSRs are much different to HVRs and it has become apparent that the core problem is unacceptable driver behaviour which needs to be addressed, irrespective of the type of road.

It has also become apparent that the safety concerns of LVSR users are different than those of HVSRs. This is largely because there tends to be a much higher incidence of vulnerable road users (NMT, pedestrians and animals) on LVSRs than on HVSRs. The challenge in such a situation is to ensure that the speed of motorised traffic is relatively low, particularly within villages. This may be achieved in a number of ways including:

- Appropriate road signage, including traffic signs and road markings;
- Use of road humps and rumble strips
- Pedestrian crossings
- Wide or separated shoulders

There is an overriding need to incorporate the above road safety measures in the LVSR design process and, to this end, a road safety audit should be undertaken as part of the road design process.

In addition to the above, road safety education and enforcement are key factors which can have a major influence on road safety on all roads and should be given high priority in order to promote a road safety “culture” for all ages of road users in Malawi.

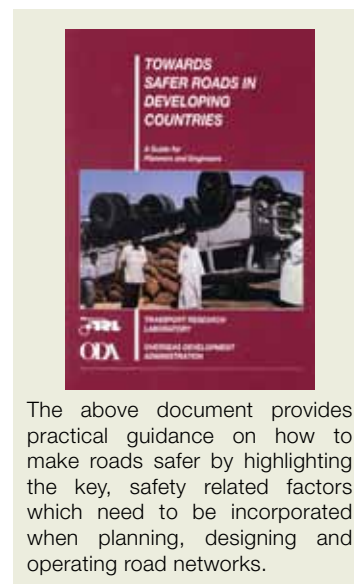

The above document provides practical guidance on how to make roads safer by highlighting the key, safety related factors which need to be incorporated when planning, designing and operating road networks.

## Bibliography

1. Assum T (1998). **Road Safety in Africa: Appraisal of Road Safety Initiatives in Five African Countries**, SSATP Working Paper No. 33, The World Bank, Washington, DC.
2. Austroads (1994). **Road Safety Audits**, NSW, Australia.
3. Dhliwayo, M E (1997). **A Review of the Road Safety Situation in Africa**, Proc. 3rd African Road Safety Conference, Pretoria.
4. National Road Safety Council of Kenya. (1990). **Manual on Accident Prevention Using Low-Cost Engineering Countermeasures**. Ministry of Public Works, Nairobi.
5. Ross A (1992). **Road Safety Checks**. Infrastructure Notes, Infrastructure and Urban Development Department, World Bank, Washington, D.C.
6. Transport Research Laboratory (1985). **Maintenance Techniques for District Engineers. Overseas Road Note 2**. TRL. Crowthorne.
7. TRL (1987). **Maintenance Management for District Engineers. Overseas Road Note 1**. TRL, Crowthorne.
8. Transport Research Laboratory, Ross Silcock Partnership and Overseas Development Administration (1991). **Towards Safer Roads in Developing Countries – A Guide for Planners and Engineers**. TRL, Berkshire, UK
9. Transport Research Laboratory (2002). **Cost and Safety Efficient (CaSE) Design of Rural Roads in Developing Countries**. TRL Unpublished Report PR/INT/242/2002, Crowthorne.
10. Weston, D.J. 1980. **Expansive soil treatment for southern Africa**. Proc. Fourth Int. Conf. on Expansive Soils, Denver.
11. Van Zyl, N J W and Freeme, C R (1984). **Determination of damage done to roads by heavy vehicles**. Proc. Annual Transport Convention, Pretoria.

## 6. COST ANALYSIS

### 6.1 Introduction

There are always a number of potential alternatives available to the designer in the design of new roads or the rehabilitation of existing ones, each capable of providing the required performance. For example, as illustrated in Figure 6-1, for a given analysis period, one alternative might entail the use of a relatively thin, inexpensive pavement which requires multiple strengthening interventions (Alternative A) whilst another alternative might entail the use of a thicker, more costly pavement with fewer interventions (Alternative B).

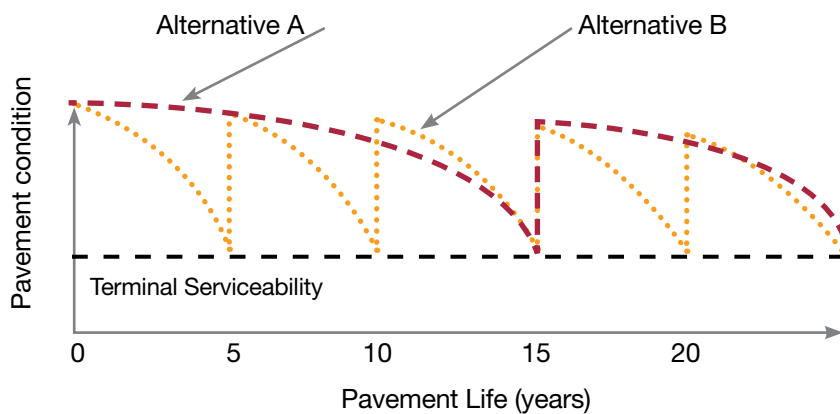

Figure 6-1: Alternative pavement options

In order to make the most effective use of the available resources, the designer is required to find which alternative will serve the needs of road users for a given level of service at the lowest cost over time. Such a task can be achieved through the use of a life-cycle economic evaluation, often referred to as “life-cycle” or “whole-of-life” costing.

### 6.2 Life-Cycle Cost Analysis

A life-cycle cost (LCC) analysis requires identifying and evaluating the economic consequences of various alternatives over time primarily according to the criterion of minimum total (life-cycle) costs.

As indicated in Figure 6-2, the principal components of a LCC analysis are the initial investment or construction cost and the future costs of maintaining or rehabilitating the road, as well as the benefits due to savings in user costs over the assessment period selected. An assessment of the residual value of the road is also included so as to incorporate the possible different consequences of construction and maintenance strategies for the pavement/surface options being investigated.

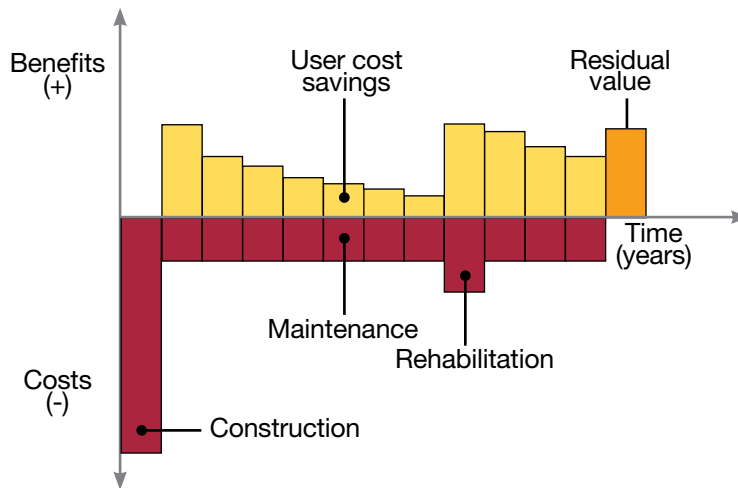

Figure 6-2: Distribution of costs and benefits during the life cycle of a road option

### Method of Economic Comparison

In the life-cycle analysis process, alternative pavement/surface options are compared by converting all the costs and benefits that may occur at different times throughout the life of each option to their present day values. Such values are obtained using discounted cash flow techniques involving the use of an appropriate discount rate, to determine the Net Present Value (NPV) of the pavement/surface options. The NPV can be calculated as follows:

$$NPV = C + \sum_i M_i (1+r)^{-x_i} - S(1+r)^{-z}$$

where NPV = present worth costs

C = present cost of initial construction

$M_i$  = cost of the  $i^{\text{th}}$  maintenance and/or rehabilitation measure

r = real discount rate

$x_i$  = number of years from the present to the  $i^{\text{th}}$  maintenance and/or rehabilitation measure, within the analysis period

z = analysis period

S = salvage value of pavement at the end of the analysis period expressed in terms of present values

### Components of LCC Analysis

The components of a LCC analysis associated with a particular design alternative are listed below and illustrated in Figure 6.3.

- Analysis period
- Structural design period
- Construction costs
- Maintenance costs
- Road user costs
- Salvage value
- Discount rate

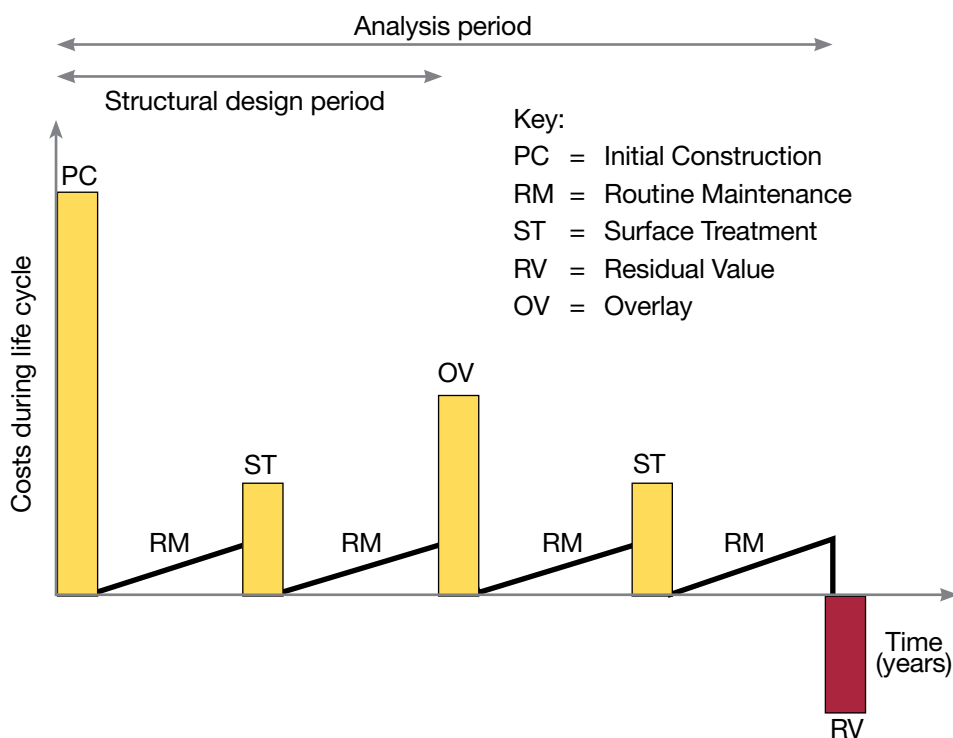

Figure 6-3: Components of a typical life cycle cost analysis

- (a) **Analysis period:** This period is the length of time for which comparisons of total costs are to be made. It should be the same for all alternative strategies and should not be less than the longest design period of the alternative strategies.
- (b) **Structural design period:** This is the design life of the road at which time it would be expected to have reached its terminal serviceability level and to require an appropriate intervention such as an overlay.
- (c) **Construction costs:** Unit costs for alternative pavement designs will vary widely depending on such factors as locality, availability of suitable materials, scale of project and road standard. Other factors that would typically warrant consideration include:
- Land acquisition costs
  - Supervision and overhead cost
  - Establishment costs
  - Accommodation of traffic
  - Relocation of services
- (d) **Maintenance costs:** The nature and extent of future maintenance will be dependent on pavement composition, traffic loading and environmental influences. An assessment needs to be made of future annual routine maintenance requirements, periodic treatments such as reseals, and rehabilitation such as structural overlays.
- (e) **Road user costs:** These are normally not considered in a LCC analysis, as the pavement designs are considered to provide “equivalent service” during the analysis period. However, when evaluating the viability of costly measures to improve or maintain a high roughness level, e.g. treatments for expansive clays, the savings for the road user (vehicle operating costs) compared with the cheapest option are treated as benefits and should be incorporated as one of the components in the LCC analysis (ref. Figure 6-2).

- (f) **Salvage value:** The value of the pavement at the end of the analysis period depends on the extent to which it can be utilised in any future upgrading. For example, where the predicted condition of the pavement at the end of the analysis period is such that the base layer could serve as the subbase layer for the subsequent project, then the salvage value would be equal to the cost in current value terms for construction in future to subbase level discounted to the evaluation year.
- (g) **Discount rate:** This rate must be selected to express future expenditure in terms of present values and cost. The decision on discount rate is usually based on a combination of policy and economic considerations.

### 6.3 Optimum Pavement Design Solution

The optimum pavement design solution, which should be the design objective, is a balance between construction, maintenance and road user costs and, as illustrated in Figure 6.4, is very much traffic related. Thus, the optimum structural capacity pavement for a relatively low traffic pavement might well incur lower initial construction costs but, within its life cycle, this would be balanced by higher maintenance and VOC. Conversely, a higher traffic pavement would incur higher initial construction costs but lower maintenance and VOC.

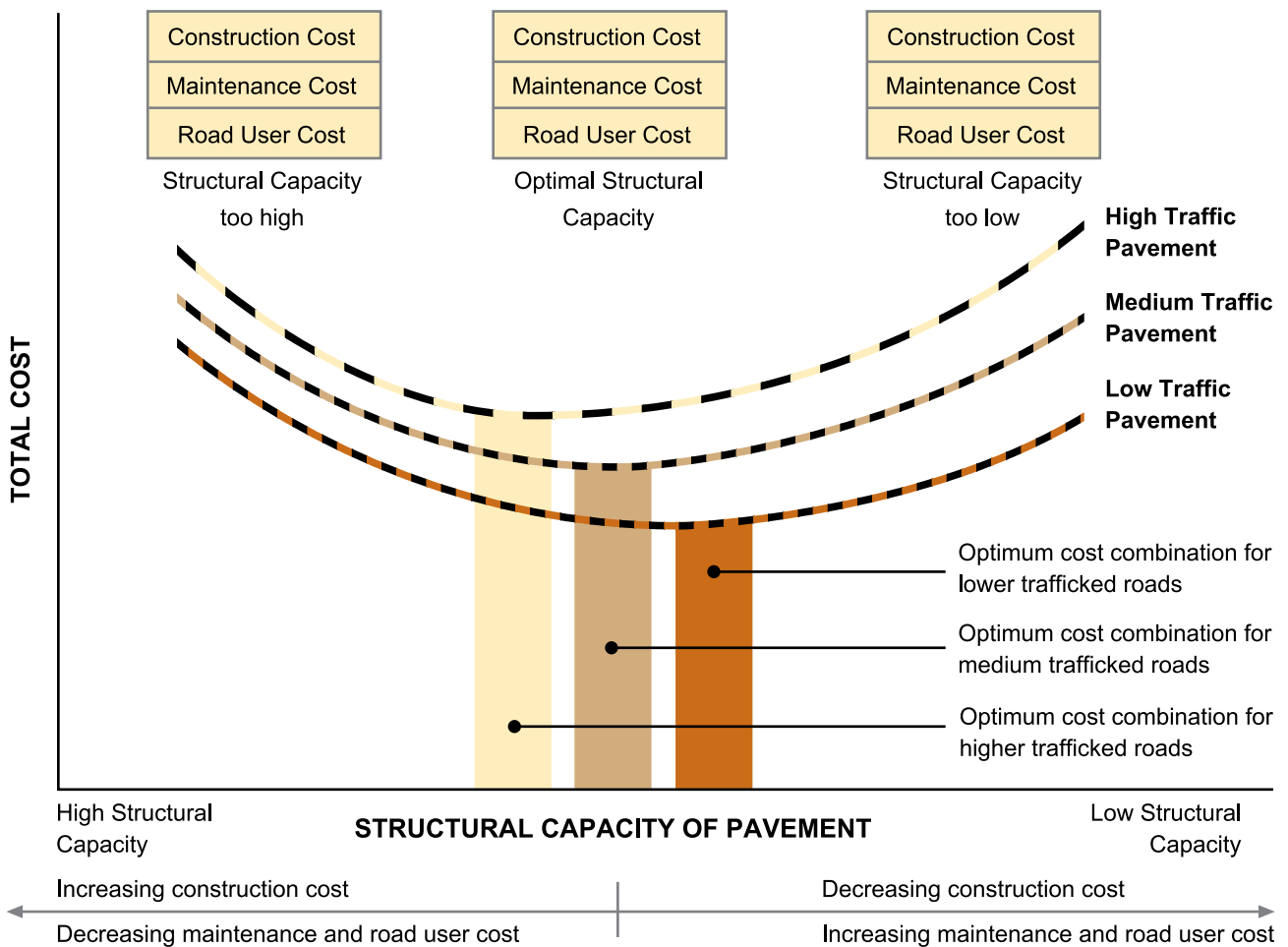

Figure 6-4: Combined cost for various pavement structure capacities

## Bibliography

1. ACPA (2002): Life Cycle Cost Analysis. ***A Guide for Alternative Pavement Designs***. American Concrete Pavement Association, Stokie, Illinois, USA.
2. Baum, W.C. (1982): The Project Cycle. International Bank for Reconstruction and Development, The World Bank, 1818 H Street, N.W. Washington, D.C. 20433, USA.
3. Goldbaum, J. (2000): ***Life Cycle Cost Analysis State-of-the-Practice***. Report No. CDOT-R1-00-3. Aurora, CO.
4. Ozbay, K et al (2003): ***Guidelines for Life Cycle Analysis. Final Report***. Report No. FHWA-NJ-2003-012. Trenton, NJ.
5. Walls, J. and M.R. Smith. (1998): ***Life Cycle Cost Analysis in Pavement Design – Interim Technical Bulletin***. Federal Highway Administration, Washington, D.C., USA.
6. Peterson, D. (1985). ***Life Cycle Cost Analysis of Pavements. Synthesis of Highway Practice***. NCHRP Report 122, Washington, D.C., USA.



## 7. IMPLEMENTATION

### 7.1 Introduction

Although no two projects are alike, each has its own history and implementation of a particular project entails following a process or cycle that, with some variations, is common to all. As illustrated in Figure 7-1, the cycle typically comprises the basic stages of planning, design, construction and maintenance. Each phase has important, but changing, impacts on the end result in terms of its “level of influence” on the succeeding phase and the related effect on the total cost of the project.

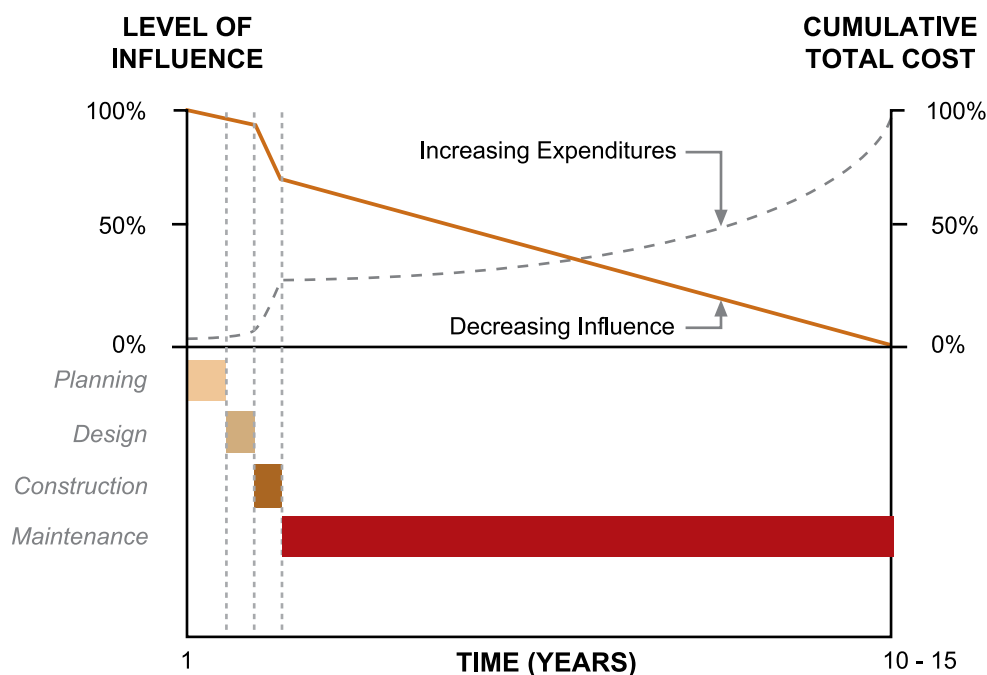

Figure 7-1: Road project cycle and influence on final cost

Ultimately, the successful implementation of a project should be such as to meet all the objectives of the project cycle within the budget and time constraints. This requires that the implementing agency is organised to function in a seamless manner as the project progresses from one phase to the next.

### 7.2 Planning Impacts

The planning phase of the project provides the “what, when and where” type of information to the design and subsequent phases of the project. Information on the type of project required (e.g. paved, unpaved, standard, etc.), its location (e.g. alignment within a corridor), how it is to be constructed (e.g. labour or equipment based) invariably provides direction for the design stage of the project and, indeed, the impact/influence on the construction and maintenance phases of the project.

As indicated in Figure 7-1, the costs incurred during the planning phase are relatively small compared with the total expenditure and are incurred during a relatively short period of the project’s life. However, the downstream level of influence of planning is very large in terms of decisions and commitments made during the early phases of the project.

## 7.3 Design Impacts

The design phase of the project in terms of the preparation of plans, specifications and tender documents provide a direct and influential input for construction and represents the most obvious and direct interaction between these phases.

The traditional outputs of the design phase are plans and specifications which provide a direct input for construction and typically comprise the following:

- A set of drawings that provide detailed longitudinal and cross-section details and other design aspects
- A set of specifications that describe in detail the materials to be provided and construction standards to be achieved

In addition to the contract documents and details for construction, proper interaction in the early stages can assist the construction in the preliminary field engineering phase and in establishing methods for locating materials and establishing quality and quantity control techniques.

As is the case with the planning phase, the costs incurred during the design phase of the project are relatively small compared with the total expenditure but the impact/influence is enormous on the construction and maintenance phases of the project. A well designed project coupled with responsive tender documents are absolutely crucial if the final product is to achieve its primary objective in terms of providing an optimum design solution at minimum life-cycle costs.

## 7.4 Construction Impacts

The construction phase of a road project converts a design recommendation into physical reality. Successful construction meets the planning and design objectives within budget and time constraints. In order to move the selected road design to the construction phase, a set of definitive documents expressing the details of the selected design, or of the alternative offered for contract tenders, is needed. These documents not only convey details to construction but also serve as legal documents in procuring the services of a contractor.

The construction phase of a project will suffer if there are shortcomings in the tender documents in terms of such factors as misleading materials information, inaccurate quantities or impractical specifications. Such shortcomings are not uncommon on many projects in Malawi and inevitably lead to an escalation of costs due to claims and delays to project completion.

Whilst the capital costs of construction are a fraction of the operating and maintenance costs, the actual quality of construction can greatly impact on the cost of maintaining the road. This emphasises the importance of ensuring a high degree of quality control in the use of local materials and the adoption of construction methods that are appropriate to the multi-dimensional environment in which the road is being provided.

Feedback from construction to design is also vital. A seemingly economical design is not effective if it results in unusual or unmanageable construction problems. Such feedback can often lead to a change in future specifications and more cost-effective designs.

## 7.5 Maintenance Impacts

The last phase considered in relation to the preceding phases of the project cycle is maintenance. This crucial activity occupies a significant number of years in the life of the project and the type and cost of the activities required is influenced significantly by the preceding planning, design and construction phases.

Careful consideration of the type of maintenance undertaken and its location along the road may show some patterns of pavement behaviour that feed back to construction and show weaknesses in design specifications and construction methods.

As regards the information flows from construction to maintenance, effective maintenance techniques and procedures are dependent on the actual materials and construction methods used. They are also related to the problems that were encountered during construction. For example, poor pavement performance can often be shown to be due to the use of sub-standard materials, inadequate compaction or non-consideration of drainage impacts. This emphasises the importance of ensuring a high degree of quality control in the use of local materials and the adoption of construction methods that are appropriate to the environment in which the road is being provided.

## 7.6 Pavement Monitoring Impacts

Periodic monitoring and evaluation of existing roads are desirable as they can show that certain construction methods and technology, although acceptable under existing specifications, lead to premature failure and rapid deterioration. For example, seemingly sound materials may degrade in service which may lead to structural weaknesses. Monitoring the roughness progression would also confirm assumptions in terms of different strategies and identify the terminal service level after which rehabilitation would be required.

A good feedback system can also assist in solving many potential design and construction problems. In this regard, the as-built construction records form the cornerstone of the maintenance database. Such information provides the initial or zero-age evaluation of the pavement. Moreover, if the construction data is good and effectively recoded, it will form the backbone of all future evaluation because the data will be more detailed than can ever be obtained again. In addition, these records can be used to assist in selecting the initial location of pavement sections to be periodically monitored.

## 7.7 Environmental Impacts

The implementation of a road project has a major effect on the immediate environment. The overall impact is basically its very presence, but its most visible impact on the natural environment is often during the construction phase. Appropriate measures should therefore be put in place for dealing with environmental impacts during prior to construction, in the form of an Environmental Impact Assessment Study, and during construction for which the following is a typical checklist of issues to be addressed:

**Consequential developments:**

Will the project stimulate land clearance for agriculture, the development of industry or mineral extraction? What steps can be taken to mitigate long-term adverse effects?

**Social factors:**

Has adequate provision been made for vehicle, pedestrian and NMT safety. Are the geometric standards adopted likely to require provision of additional safety countermeasures (e.g. signage, education programmes)?

**Geotechnical damage:**

Has the project been designed to minimise the possibility of landslides and other geotechnical problems? Have long-term maintenance consequences been taken into account?

**Materials resources:**

Will the project result in the unacceptable depletion of material resources that may be needed for subsequent maintenance or other construction projects? Will borrow pits be restored and can their effect on the landscape be minimised?

**Drainage:**

Will the project result in increased risks from flooding or landslides as a result of disturbing natural drainage patterns? Will later development of agricultural land and other settlements affect hydrological conditions so that drainage works and bridges must be modified? Will any water impoundments create health hazards?

**Ecology:**

Have the effects on animals and plants been considered? Has an ecological reconnaissance been carried out to assess these effects?

**Other factors:**

Are air pollution, noise and vibration, and visual intrusion issues of concern in the project? If so, what can be done to mitigate the effects?

## Bibliography

1. ACPA (2002): Life Cycle Cost Analysis. ***A Guide for Alternative Pavement Designs***. American Concrete Pavement Association, Stokie, Illinois, USA.
2. Baum, W.C. (1982): ***The Project Cycle***. International Bank for Reconstruction and Development, The World Bank, 1818 H Street, N.W. Washington, D.C. 20433, USA.
3. Goldbaum, J. (2000): ***Life Cycle Cost Analysis State-of-the-Practice***. Report No. CDOT-R1-00-3. Aurora, CO.
4. Ozbay, K et al (2003): ***Guidelines for Life Cycle Analysis***. Final Report. Report No. FHWA-NJ-2003-012. Trenton, NJ.
5. Walls, J. and M.R. Smith. (1998): ***Life Cycle Cost Analysis in Pavement Design – Interim Technical Bulletin***. Federal Highway Administration, Washington, D.C., USA.
6. Peterson, D. (1985). ***Life Cycle Cost Analysis of Pavements. Synthesis of Highway Practice***. NCHRP Report 122, Washington, D.C., USA.

Annex: **A**  
**DCP Design**  
**Example**

## ANNEX A – DCP DESIGN EXAMPLE

### A.1 Project Details

- Project name: Alpha-Beta Road
- Road length: 17 km
- DCP survey carried out in dry season

### A.2 Design Procedure

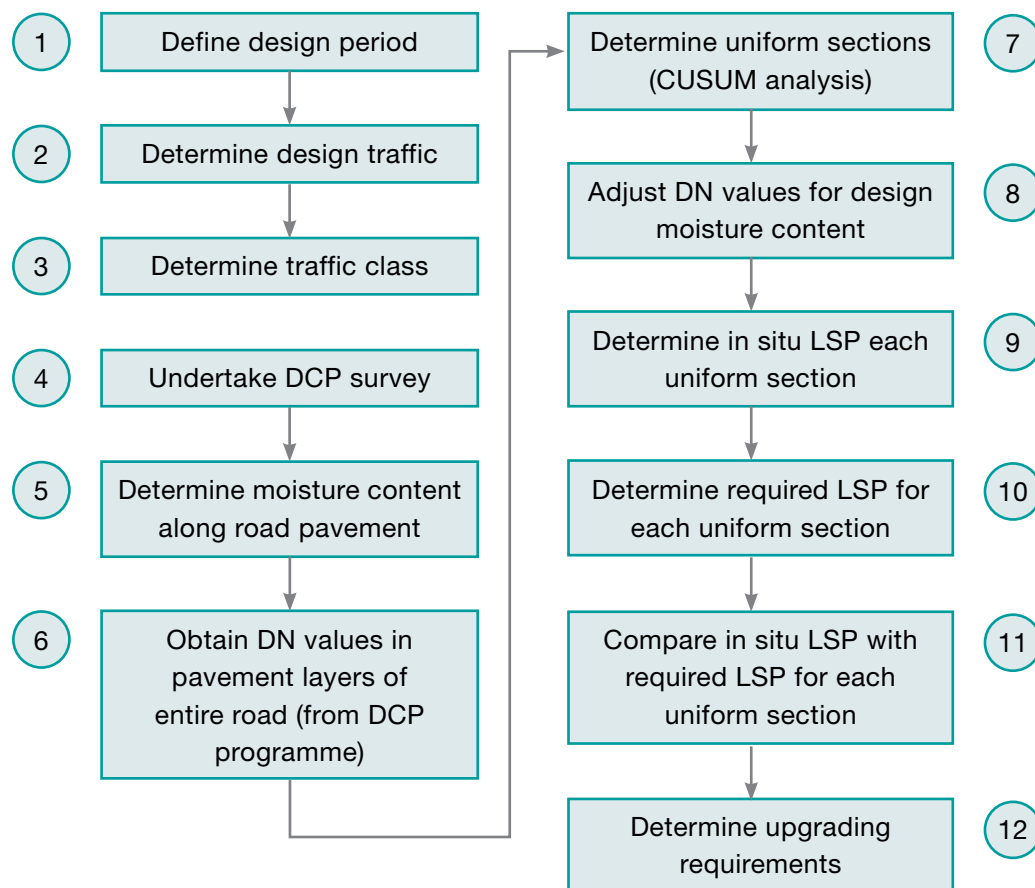

Figure 5-4: Flow diagram of DCP design procedure

### A.3 Step 1 – Design Period

- Design period = 20 years

### A.4 Step 2 – Design Traffic

- 0.18 MESA (see Part B, Chapter 3, Annex 3B – Determination of Design Traffic Loading).

### A.5 Step 3 – Traffic Class

- Traffic Class = LV 0.3 (0.10 – 0.30 MESA) (see Part B, Chapter 3, Table 3-5)

## A.6 Step 4: DCP Survey

- The DCP survey was carried out during the dry season.
- The results of the DCP survey are presented in Annex A.1 of this annex.

## A.7 Step 5: Moisture Content Along Road Pavement

- From laboratory determinations, the average moisture content of samples taken at every 500 m from the outer wheel track of the road at depths of 0-150, 150-300 and 300-450 mm is generally below OMC.

## A.8 Step 6: DN Values in Pavement Layers

- The 20th, 50th and 80th pavement layer DN values as obtained from the DCP programme are presented in Annex A-1 of this annex.

## A.9 Step 7: Uniform Sections

- The uniform sections determined from a CUSUM analysis of the DCP results (see Chapter 2, Annex 2B which illustrates the manner of undertaking such an analysis) are presented in Annex A-1 of this annex.
- The uniform sections determined from the CUSUM analysis are illustrated in a chart in Annex A.3 of this annex and are as follows:

Table A-1: Chainage of uniform sections

Uniform Section No.	Chainage (km)
1	0.0 – 2.5
2	2.5 – 6.0
3	6.0 – 7.5
4	7.5 – 10.0
5	10.0 – 12.5
6	12.5 – 14.5
7	14.5 – 17.0

## A.10 Step 8: Adjustment of DN Values for Design Moisture Content

- From consideration of the outputs of Step 5 it is assessed that the long-term, in-service moisture content in the pavement (sealed shoulders and adequate drainage with minimum crown height of 0.75 m) will be wetter than at the time of the DCP survey. Accordingly, the 80th percentile DN values are used for determining the in situ layer strength profile of each uniform section. as presented in Annex A.4 of this annex. (see also Section B, Chapter 2, Annex 2C which illustrates the manner of determining and choosing DN percentile values).

## A.11 Step 9: In Situ Layer-Strength Profile for Uniform Sections

- The in situ layer-strength profile for each uniform section is determined from the DCP programme by undertaking an 'average analysis' of each uniform section. The DCP programme computes the 20th, 50th or 80th DN values for each layer of each uniform section and provides a graphical representation of the data compared with the DN traffic class of the road to be designed – in this case Traffic Class LV 0.3.

- A typical printout for Uniform Section 4 (Chainage 7.5 – 10.0 km) is shown in Figure A-1 while printouts for all sections are presented in Annex A.5 of this annex.

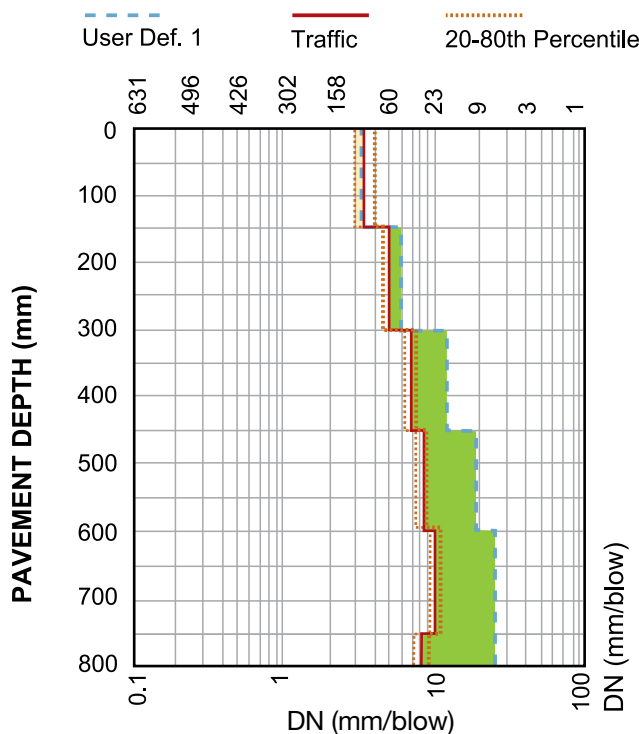

Figure A-1: Uniform Section No. 4 - Layer-Strength diagram (LSD)

### A.12 Step 10: Required layer-Strength Profile

- Although the required layer strength profile is automatically produced from the DCP programme as described in Step 9, it should also be obtained from Table 5-1 (see Chapter 5 as follows (see Section B, Chapter 5, Table 5-1) to facilitate a more comprehensive understanding of the design process. The required layer strength profile for Traffic Class LV 0.3 is presented below.

Traffic Class E80 x 106	LE 0.3 0.100 – 0.300
0- 150 mm Base ≥ 98% MAASHTO	DN ≤ 3.2 mm/blow
150-300 mm Subbase ≥ 95% MAASHTO	DN ≤ 6 mm/blow
300-450 mm subgrade ≥ 95% MAASHTO	DN ≤ 12 mm/blow
450-600 mm In situ material	DN ≤ 19 mm/blow
600-800 mm In situ material	DN ≤ 25 mm/blow

### A.13 Step 11: Comparison of In Situ and Required Layer-Strength Profiles for Uniform Sections

- Figure A-1 above indicates that for an 80th percentile moisture condition, the strength of the 0 – 150 mm layer for Uniform Section 4 is less than that required but is adequate for all the other layers to a depth of 800 mm.
- A comparison of the in situ and required layer-strength profiles can also be presented manually for each uniform section to facilitate the determination of upgrading requirements as illustrated in Table A-2.

Summary of design outputs.

**Table A-2: Comparison of in situ and required layer strength profiles for uniform sections**

Pavement Layer (mm)	Required DN Value for LV 0.3	DN Values - 80th Percentile*						
		Section no.						
		1	2	3	4	5	6	7
0-150	≤3.2	8.07	4.81	4.90	4.03	4.45	6.57	3.95
150-300	≤6	10.47	7.75	10.07	5.37	5.99	9.71	4.94
300-450	≤12	9.69	8.78	10.27	7.79	7.09	9.68	7.37

Inadequate in situ layer

Adequate in situ layer(s)

\* As obtained in the manner described in Annex B-2.

### A.14 Step 12: Determine Upgrading Requirements

- As illustrated in Table A-2, the in situ strength of the uppermost 150 mm layer of the existing unpaved road (DN range 3.95 – 8.07 mm/blow) is all below the required strength (max. DN value of 3.2 mm/blow). Thus, at least a new base layer of the required strength will be required.
- As illustrated in Table A-3, the effect of adding a new base layer is to subjugate the existing base layer to that of a subbase layer with a lower strength requirement which must be evaluated against the required DN value of ≤ 6.

Table A-3: Impact of imported base layer on layer-strength profiles

Pavement Layer (mm)	Required DN Value for LV 0.3	DN Values - 80th Percentile						
		Section no.						
		1	2	3	4	5	6	7
0-150	≤3.2	3.20	3.20	3.20	3.20	3.20	3.20	3.20
150-300	≤6	8.07	4.81	4.90	4.03	4.45	6.57	3.95
300-450	≤12	10.47	7.75	10.07	5.37	5.99	9.71	4.94
450-600	≤19	9.69	8.78	10.27	7.79	7.09	9.68	7.37

- Required new base with DN value ≤ 3.2
- Inadequate in situ layer(s)
- Adequate in situ layer(s)

- As illustrated in Table A-3, the strength of the new subbase (previously the base of the existing gravel road) in two of the uniform sections, Sections 1 and 6, is inadequate (DN value > 6). Thus, a new subbase layer of the requisite strength is also required for these sections to produce an adequate pavement structure for all sections as illustrated in Table A-4.

Table A-4: Impact of imported base and subbase layers on layer-strength profiles

Pavement Layer (mm)	Required DN Value for LV 0.3	DN Values - 80th Percentile						
		Section no.						
		1	2	3	4	5	6	7
0-150	≤3.2	3.20	3.20	3.20	3.20	3.20	3.20	3.20
150-300	≤6	6.00	4.81	4.90	4.03	4.45	6.60	3.95
300-450	≤12	8.07	7.75	10.07	5.37	5.99	9.71	4.94
450-600	≤19	10.47	8.78	10.27	7.79	7.09	9.71	7.37

- Required new base with DN value ≤ 3.2
- Required new subbase with DN value ≤ 6.00
- Adequate in situ layer(s)

- In summary, a new base layer with a required DN value of  $\leq 3.2$  will be required for all the uniform sections whilst a new subbase layer with a DN value of  $\leq 6.00$  will be required for uniform sections 1 and 6.
- The new base and subbase requirements may be achieved in a number of ways, including:
  - **Reworking the existing layer** - if only the density is inadequate and the required DN value can be obtained at the specified construction density and anticipated in-service moisture content
  - **Replacing the existing layer** - if the material quality (DN value at the specified construction density and anticipated in-service moisture content) is inadequate, then appropriate quality material will need to be imported to serve as the new upper pavement layer(s)
  - **Augmenting the existing layer** - if the material quality (DN value) is adequate but the layer thickness is inadequate, then imported material of appropriate quality will need to be imported to make up the required thickness prior to compaction

### A.15 Evaluation of In Situ or Borrow Pit Materials

The in situ or imported materials to be used for the new pavement layers should be evaluated in terms of assessing their DN values at the anticipated operational in-service moisture content and density as described in Annex 6A.

**ANNEX A1: Alpha-Beta Road: DCP Results and Analysis**

Point No.	Chainage (km)	DSN800 (blows)			DN Base (0-150 mm) (mm/blow)			DN Subbase (150-300 mm) (mm/blow)			DN Subgrade (300-450 mm) (mm/blow)					
		DSN800	Avg	DSN-Avg	CUSUM	DNBase	Avg	DSN-Avg	CUSUM	DN SB	Avg	DSN-Avg	CUSUM	DN SG	Avg	DSN-Avg
1	0	289	206.77	82.23	82.23	2.29	4.11	-1.82	-1.82	5.15	6.33	-1.18	3.06	7.57	-4.51	-4.51
2	0.25	85	206.77	-121.77	-39.54	4.44	4.11	0.33	-1.49	10.80	6.33	4.47	15.33	7.57	7.76	3.25
3	0.5	180	206.77	-26.77	-66.30	2.00	4.11	-2.11	-3.60	11.63	6.33	5.30	16.69	7.57	9.12	12.37
4	0.75	95	206.77	-111.77	-178.07	8.67	4.11	4.56	0.96	8.04	6.33	1.71	7.87	7.57	0.30	12.67
5	1	135	206.77	-71.77	-249.84	3.75	4.11	-0.36	0.60	6.93	6.33	0.60	8.87	7.57	1.30	13.97
6	1.25	118	206.77	-88.77	-338.61	8.07	4.11	3.96	4.55	8.80	6.33	2.47	5.05	7.57	-2.52	11.46
7	1.5	115	206.77	-91.77	-430.38	5.11	4.11	1.00	5.55	9.37	6.33	3.04	8.05	7.57	0.48	11.94
8	1.75	120	206.77	-86.77	-517.14	5.37	4.11	1.26	6.81	6.24	6.33	-0.09	6.91	7.57	-0.66	11.28
9	2	107	206.77	-99.77	-616.91	6.60	4.11	2.49	9.30	7.17	6.33	0.84	9.69	7.57	2.12	13.40
10	2.25	110	206.77	-96.77	-713.68	10.12	4.11	6.01	15.31	10.47	6.33	4.14	9	7.57	1.43	14.83
<b>11</b>	<b>2.5</b>	<b>355</b>	<b>206.77</b>	<b>148.23</b>	<b>-565.45</b>	<b>2.45</b>	<b>4.11</b>	<b>-1.66</b>	<b>13.65</b>	<b>2.09</b>	<b>6.33</b>	<b>-4.24</b>	<b>2.73</b>	<b>7.57</b>	<b>-4.84</b>	<b>9.99</b>
12	2.75	128	206.77	-78.77	-644.22	4.74	4.11	0.63	14.28	8.05	6.33	1.72	10.19	7.57	2.62	12.61
13	3	309	206.77	102.23	-541.99	4.22	4.11	0.11	14.39	5.29	6.33	-1.04	4.36	7.57	-3.21	9.40
14	3.25	299	206.77	92.23	-449.75	3.75	4.11	-0.36	14.03	6.45	6.33	0.12	4.32	7.57	-3.25	6.15
15	3.5	304	206.77	97.23	-352.52	3.28	4.11	-0.83	13.20	7.61	6.33	1.28	4.25	7.57	-3.32	2.83
16	3.75	256	206.77	49.23	-303.29	1.86	4.11	-2.25	10.95	3.92	6.33	-16.78	7.57	-3.52	-0.68	
17	4	144	206.77	-62.77	-366.06	3.65	4.11	-0.46	10.48	7.00	6.33	0.67	4.68	7.57	-2.89	-3.57
18	4.25	176	206.77	-30.77	-396.83	2.91	4.11	-1.20	9.28	5.36	6.33	-0.97	5.72	7.57	-1.85	-5.42
19	4.5	126	206.77	-80.77	-477.59	5.03	4.11	0.92	10.20	7.84	6.33	1.51	8.57	7.57	1.00	-4.42
20	4.75	130	206.77	-76.77	-554.36	4.85	4.11	0.74	10.94	6.53	6.33	0.20	7.9	7.57	0.33	-4.09
21	5	199	206.77	-7.77	-562.13	2.93	4.11	-1.18	9.76	3.79	6.33	-2.54	6.84	7.57	-0.73	-4.82
22	5.25	145	206.77	-61.77	-623.90	3.85	4.11	-0.26	9.50	4.90	6.33	-1.43	12.93	7.57	5.36	0.54
23	5.5	161	206.77	-45.77	-669.67	2.72	4.11	-1.39	8.11	4.23	6.33	-2.10	7.28	7.57	-0.29	0.25

Point No.	Chainage (km)	DSN800 (blows)			DN Base (0-150 mm) (mm/blow)			DN Subbase (150-300 mm) (mm/blow)			DN Subgrade (300-450 mm) (mm/blow)						
		DSN800	Avg	DSN-Avg	CUSUM	DNBase	Avg	DSN-Avg	CUSUM	DN SB	Avg	DSN-Avg	CUSUM	DN SG	Avg	DSN-Avg	CUSUM
24	5.75	103	206.77	-103.77	-773.43	5.33	4.11	1.22	9.33	12.10	6.33	5.77	17.91	8.92	7.57	1.35	1.60
<b>25</b>	<b>6</b>	<b>165</b>	<b>206.77</b>	<b>-41.77</b>	<b>-815.20</b>		<b>4.11</b>	<b>-4.11</b>	<b>5.22</b>		<b>6.33</b>	<b>-6.33</b>	<b>11.58</b>		<b>7.57</b>	<b>-7.57</b>	<b>-5.97</b>
26	6.25	123	206.77	-83.77	-898.97	4.37	4.11	0.26	5.48	10.07	6.33	3.74	15.33	10.27	7.57	2.70	-3.26
27	6.5	87	206.77	-119.77	-1018.74	6.61	4.11	2.50	7.97	10.27	6.33	3.94	19.27	9.6	7.57	2.03	-1.23
28	6.75	147	206.77	-59.77	-1078.51	2.34	4.11	-1.77	6.20	6.69	6.33	0.36	19.63	13.23	7.57	5.66	4.43
29	7	141	206.77	-65.77	-1144.28	3.34	4.11	-0.77	5.43	6.28	6.33	-0.05	19.58	7	7.57	-0.57	3.86
30	7.25	102	206.77	-104.77	-1249.04	4.90	4.11	0.79	6.22	7.69	6.33	1.36	20.95	9.31	7.57	1.74	5.60
<b>31</b>	<b>7.5</b>	<b>115</b>	<b>206.77</b>	<b>-91.77</b>	<b>-1340.81</b>	<b>3.95</b>	<b>4.11</b>	<b>-0.16</b>	<b>6.06</b>	<b>7.90</b>	<b>6.33</b>	<b>1.57</b>	<b>22.52</b>	<b>9.69</b>	<b>7.57</b>	<b>2.12</b>	<b>7.72</b>
32	7.75	130	206.77	-76.77	-1417.58	4.69	4.11	0.58	6.64	5.32	6.33	-1.01	21.51	6.42	7.57	-1.15	6.57
33	8	162	206.77	-44.77	-1462.35	2.60	4.11	-1.51	5.13	4.10	6.33	-2.23	19.29	5.69	7.57	-1.88	4.69
34	8.25	168	206.77	-38.77	-1501.12	3.38	4.11	-0.73	4.40	4.07	6.33	-2.26	17.03	5.25	7.57	-2.32	2.37
35	8.5	171	206.77	-35.77	-1536.88	3.34	4.11	-0.77	3.63	4.54	6.33	-1.79	15.24	5.37	7.57	-2.20	0.17
36	8.75	190	206.77	-16.77	-1553.65	2.53	4.11	-1.58	2.05	4.80	6.33	-1.53	13.71	9.91	7.57	2.34	2.52
37	9	109	206.77	-97.77	-1651.42	5.67	4.11	1.56	3.61	8.23	6.33	1.90	15.62	7.26	7.57	-0.31	2.21
38	9.25	135	206.77	-71.77	-1723.19	3.86	4.11	-0.25	3.35	5.36	6.33	-0.97	14.65	5.13	7.57	-2.44	-0.23
39	9.5	180	206.77	-26.77	-1749.96	2.65	4.11	-1.46	1.89	4.06	6.33	-2.27	12.38	6.43	7.57	-1.14	-1.37
40	9.75	153	206.77	-53.77	-1803.72	3.37	4.11	-0.74	1.15	5.03	6.33	-1.30	11.09	6.43	7.57	-1.14	-2.51
<b>41</b>	<b>10</b>	<b>173</b>	<b>206.77</b>	<b>-33.77</b>	<b>-1837.49</b>	<b>2.35</b>	<b>4.11</b>	<b>-1.76</b>	<b>-0.61</b>	<b>5.40</b>	<b>6.33</b>	<b>-0.93</b>	<b>10.16</b>	<b>11.42</b>	<b>7.57</b>	<b>3.85</b>	<b>1.34</b>
42	10.25	179	206.77	-27.77	-1865.26	-	4.11	-4.11	-4.72	-	6.33	-6.33	3.83	-	7.57	-7.57	-6.23
43	10.5	183	206.77	-23.77	-1889.03	1.65	4.11	-2.46	-7.18	-	6.33	-6.33	-2.50	-	7.57	-7.57	-13.80
44	10.75	187	206.77	-19.77	-1908.80	3.34	4.11	-0.77	-7.95	4.59	6.33	-1.74	-4.23	4.7	7.57	-2.87	-16.67
45	11	117	206.77	-89.77	-1998.57	4.47	4.11	0.36	-7.59	5.71	6.33	-0.62	-4.85	8.43	7.57	0.86	-15.81
46	11.25	960	206.77	753.23	-1245.33	-	4.11	-4.11	-11.70	-	6.33	-6.33	-11.18	-	7.57	-7.57	-23.37

47	11.5	192	206.77	-14.77	1260.10	3.32	4.11	-0.79	-12.49	3.80	6.33	-2.53	-13.70	4.7	7.57	-2.87	-26.24
48	11.75	222	206.77	15.23	1244.87	2.85	4.11	-1.26	-13.76	2.34	6.33	-3.99	-17.69	5.43	7.57	-2.14	-28.38
49	12	121	206.77	-85.77	1330.64	4.45	4.11	0.34	-13.42	7.11	6.33	0.78	-16.91	6.76	7.57	-0.81	-29.19
50	12.25	915	206.77	708.23	-622.41	-	4.11	-4.11	-17.53	-	6.33	-6.33	-23.23	-	7.57	-7.57	-36.76
<b>51</b>	<b>12.5</b>	<b>975</b>	<b>206.77</b>	<b>768.23</b>	<b>145.83</b>	-	<b>4.11</b>	<b>-4.11</b>	<b>-21.64</b>	-	<b>6.33</b>	<b>-6.33</b>	<b>-29.56</b>	-	<b>7.57</b>	<b>-7.57</b>	<b>-44.33</b>
52	12.75	112	206.77	-94.77	51.06	11.71	4.11	7.60	-14.04	10.97	6.33	4.64	-24.92	10.38	7.57	2.81	-41.52
53	13	900	206.77	693.23	744.29	2.73	4.11	-1.38	-15.42	-	6.33	-6.33	-31.25	-	7.57	-7.57	-49.09
54	13.25	102	206.77	-104.77	639.52	6.63	4.11	2.52	-12.90	9.85	6.33	3.52	-27.72	8.12	7.57	0.55	-48.54
55	13.5	140	206.77	-66.77	572.75	3.07	4.11	-1.04	-13.94	6.85	6.33	0.52	-27.20	8.27	7.57	0.70	-47.84
56	13.75	132	206.77	-74.77	497.99	4.47	4.11	0.36	-13.58	5.87	6.33	-0.46	-27.66	9.22	7.57	1.65	-46.18
57	14	102	206.77	-104.77	393.22	6.47	4.11	2.36	-11.22	8.53	6.33	2.20	-25.45	8.12	7.57	0.55	-45.63
58	14.25	86	206.77	-120.77	272.45	6.12	4.11	2.01	-9.21	8.08	6.33	1.75	-23.70	9.8	7.57	2.23	-43.40
<b>59</b>	<b>14.5</b>	<b>140</b>	<b>206.77</b>	<b>-66.77</b>	<b>205.68</b>	<b>2.71</b>	<b>4.11</b>	<b>-1.40</b>	<b>-10.62</b>	<b>9.13</b>	<b>6.33</b>	<b>2.80</b>	<b>-20.90</b>	<b>7.26</b>	<b>7.57</b>	<b>-0.31</b>	<b>-43.71</b>
60	14.75	180	206.77	-26.77	178.91	4.53	4.11	0.42	-10.20	3.99	6.33	-2.34	-23.24	4.65	7.57	-2.92	-46.63
61	15	290	206.77	83.23	262.14	1.77	4.11	-2.34	-12.54	3.98	6.33	-2.35	-25.58	6.34	7.57	-1.23	-47.86
62	15.25	171	206.77	-35.77	226.38	3.67	4.11	-0.44	-12.98	4.97	6.33	-1.36	-26.94	6.58	7.57	-0.99	-48.85
63	15.5	203	206.77	-3.77	222.61	3.38	4.11	-0.73	-13.71	2.85	6.33	-3.48	-30.42	4.17	7.57	-3.40	-52.25
64	15.75	193	206.77	-13.77	208.84	1.98	4.11	-2.13	-15.84	4.94	6.33	-1.39	-31.80	-	7.57	-7.57	-59.82
65	16	184	206.77	-22.77	186.07	2.19	4.11	-1.92	-17.76	4.96	6.33	-1.37	-33.17	8.56	7.57	0.99	-58.83
66	16.25	206	206.77	-0.77	185.30	2.63	4.11	-1.48	-19.24	3.92	6.33	-2.41	-35.58	4.64	7.57	-2.93	-61.76
67	16.5	164	206.77	-42.77	142.54	3.80	4.11	-0.31	-19.55	3.27	6.33	-3.06	-38.64	6.48	7.57	-1.09	-62.84
68	16.75	169	206.77	-37.77	104.77	2.69	4.11	-1.42	-20.97	4.76	6.33	-1.57	-40.20	6.58	7.57	-0.99	-63.83
<b>69</b>	<b>17</b>	<b>102</b>	<b>206.77</b>	<b>-104.77</b>	<b>0.00</b>	<b>4.53</b>	<b>4.11</b>	<b>0.42</b>	<b>-20.55</b>	<b>2.24</b>	<b>6.33</b>	<b>-4.09</b>	<b>-44.29</b>	<b>10.85</b>	<b>7.57</b>	<b>3.28</b>	<b>-60.55</b>

## ANNEX A2: Determination of 80<sup>th</sup> Percentile Values for Uniform Sections

Point No.	Chainage (km)	CUSUM				80th Percentile			
		DSN800	Base	SB	SG	DSN800	DN Base	DN SB	DN SG
1	0	82.23	-1.82	-1.18	-4.51				
2	0.25	-39.54	-1.49	3.30	3.25				
3	0.5	-66.30	-3.60	8.60	12.37				
4	0.75	-178.07	0.96	10.31	12.67				
5	1	-249.84	0.60	10.91	13.97				
6	1.25	-338.61	4.55	13.39	11.46				
7	1.5	-430.38	5.55	16.43	11.94				
8	1.75	-517.14	6.81	16.34	11.28				
9	2	-616.91	9.30	17.19	13.40				
10	2.25	-713.68	15.31	21.33	14.83				
<b>11</b>	<b>2.5</b>	<b>-565.45</b>	<b>13.65</b>	<b>17.09</b>	<b>9.99</b>	<b>180.0</b>	<b>8.07</b>	<b>10.47</b>	<b>9.69</b>
12	2.75	-644.22	14.28	18.81	12.61				
13	3	-541.99	14.39	17.78	9.40				
14	3.25	-449.75	14.03	17.90	6.15				
15	3.5	-352.52	13.20	19.18	2.83				
16	3.75	-303.29	10.95	16.78	-0.68				
17	4	-366.06	10.48	17.45	-3.57				
18	4.25	-396.83	9.28	16.48	-5.42				
19	4.5	-477.59	10.20	18.00	-4.42				
20	4.75	-554.36	10.94	18.20	-4.09				
21	5	-562.13	9.76	15.66	-4.82				
22	5.25	-623.90	9.50	14.23	0.54				
23	5.5	-669.67	8.11	12.14	0.25				
24	5.75	-773.43	9.33	17.91	1.60				
<b>25</b>	<b>6</b>	<b>-815.20</b>	<b>5.22</b>	<b>11.58</b>	<b>-5.97</b>	<b>273..2</b>	<b>4.81</b>	<b>7.75</b>	<b>8.78</b>
26	6.25	-898.97	5.48	15.33	-3.26				
27	6.5	-1018.74	7.97	19.27	-1.23				
28	6.75	-1078.51	6.20	19.63	4.43				
29	7	-1144.28	5.43	19.58	3.86				
30	7.25	-1249.04	6.22	20.95	5.60				
<b>31</b>	<b>7.5</b>	<b>-1340.81</b>	<b>6.06</b>	<b>22.52</b>	<b>7.72</b>	<b>141.0</b>	<b>4.90</b>	<b>10.07</b>	<b>10.27</b>
32	7.75	-1417.58	6.64	21.51	6.57				
33	8	-1462.35	5.13	19.29	4.69				
34	8.25	-1501.12	4.40	17.03	2.37				
35	8.5	-1536.88	3.63	15.24	0.17				
36	8.75	-1553.65	2.05	13.71	2.52				
37	9	-1651.42	3.61	15.62	2.21				
38	9.25	-1723.19	3.35	14.65	-0.23				

39	9.5	-1749.96	1.89	12.38	-1.37				
40	9.75	-1803.72	1.15	11.09	-2.51				
<b>41</b>	<b>10</b>	<b>-1837.49</b>	<b>-0.61</b>	<b>10.16</b>	<b>1.34</b>	<b>174.4</b>	<b>4.03</b>	<b>5.37</b>	<b>7.79</b>
42	10.25	-1865.26	-4.72	3.83	-6.23				
43	10.5	-1889.03	-7.18	-2.50	-13.80				
44	10.75	-1908.80	-7.95	-4.23	-16.67				
45	11	-1998.57	-7.59	-4.85	-15.81				
46	11.25	-1245.33	-11.70	-11.18	-23.37				
47	11.5	-1260.10	-12.49	-13.70	-26.24				
48	11.75	-1244.87	-13.76	-17.69	-28.38				
49	12	-1330.64	-13.42	-16.91	-29.19				
50	12.25	-622.41	-17.53	-23.23	-36.76				
<b>51</b>	<b>12.5</b>	<b>145.83</b>	<b>-21.64</b>	<b>-29.56</b>	<b>-44.33</b>	<b>167.4</b>	<b>4.45</b>	<b>5.59</b>	<b>7.09</b>
52	12.75	51.06	-14.04	-24.92	-41.52				
53	13	744.29	-15.42	-31.25	-49.09				
54	13.25	639.52	-12.90	-27.72	-48.54				
55	13.5	572.75	-13.94	-27.20	-47.84				
56	13.75	497.99	-13.58	-27.66	-46.18				
57	14	393.22	-11.22	-25.45	-45.63				
58	14.25	272.45	-9.21	-23.70	-43.40				
<b>59</b>	<b>14.5</b>	<b>205.68</b>	<b>-10.62</b>	<b>-20.90</b>	<b>-43.71</b>	<b>140.0</b>	<b>6.57</b>	<b>9.71</b>	<b>9.68</b>
60	14.75	178.91	-10.20	-23.24	-46.63				
61	15	262.14	-12.54	-25.58	-47.86				
62	15.25	226.38	-12.98	-26.94	-48.85				
63	15.5	222.61	-13.71	-30.42	-52.25				
64	15.75	208.84	-15.84	-31.80	-59.82				
65	16	186.07	-17.76	-33.17	-58.83				
66	16.25	185.30	-19.24	-35.58	-61.76				
67	16.5	142.54	-19.55	-38.64	-62.84				
68	16.75	104.77	-20.97	-40.20	-63.83				
<b>69</b>	<b>17</b>	<b>0.00</b>	<b>-20.55</b>	<b>-44.29</b>	<b>-60.55</b>	<b>203.6</b>	<b>3.95</b>	<b>4.94</b>	<b>7.37</b>

### ANNEX A3: Uniform Sections

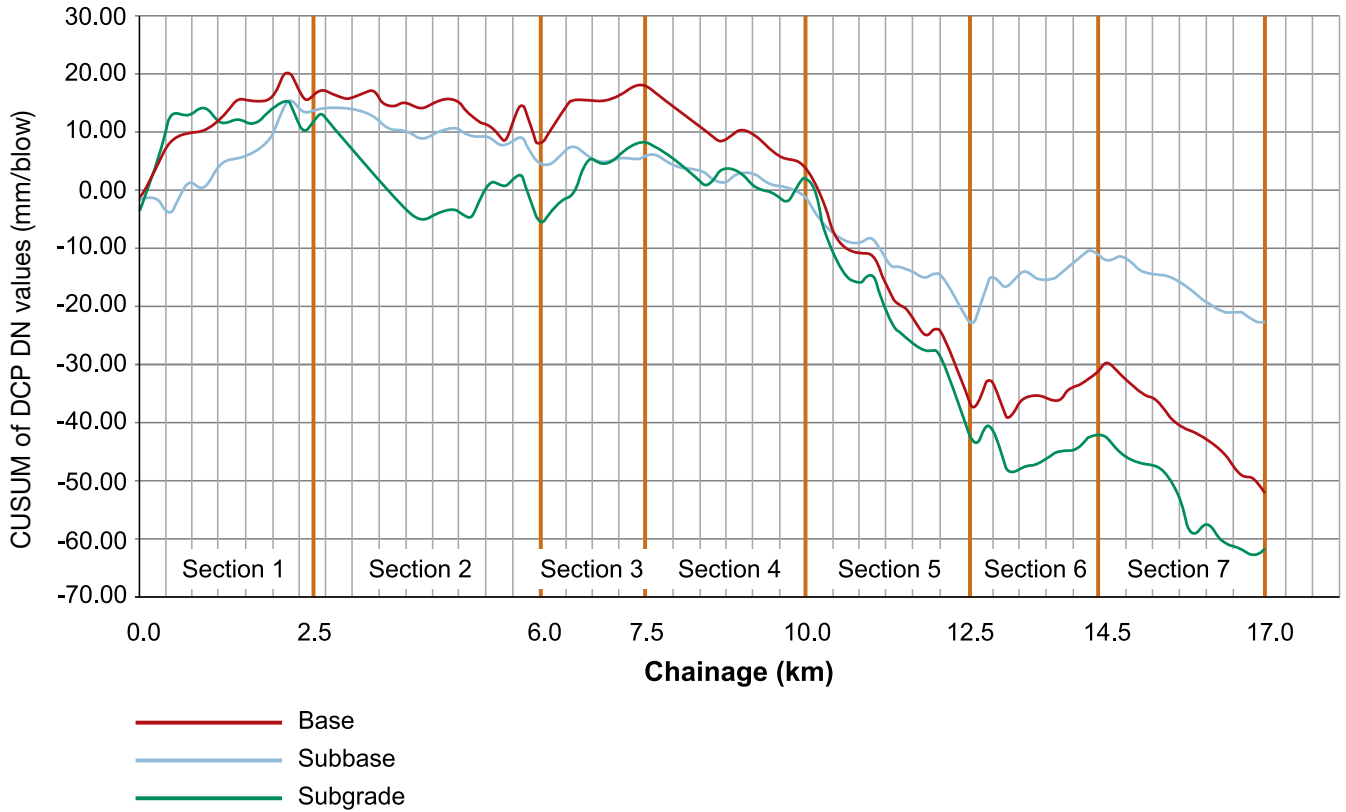

### ANNEX A4: Layer Strength Diagrams

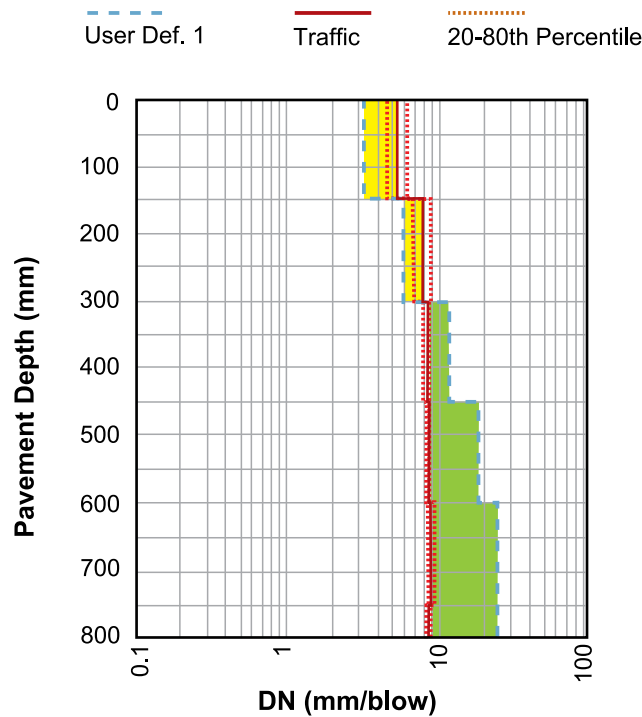

Uniform Section 1: Chainage 0.0 - 2.5

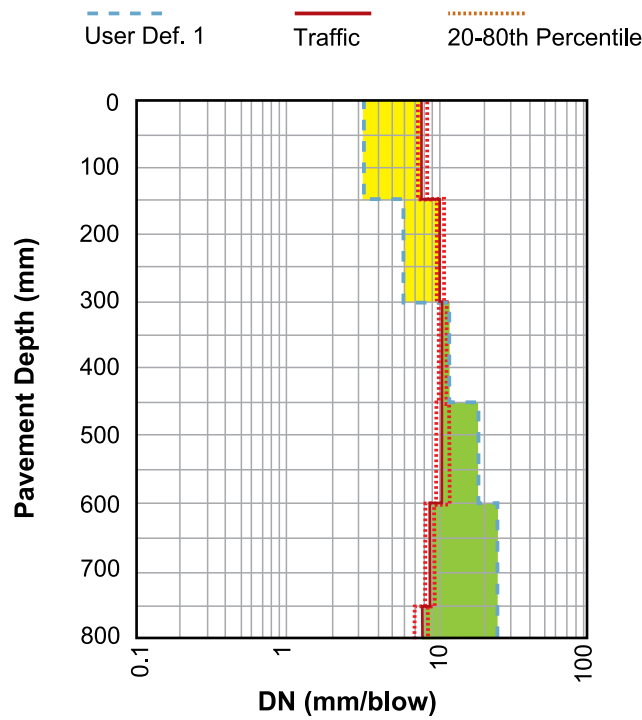

Uniform Section 2: Chainage 2.5 – 6.0

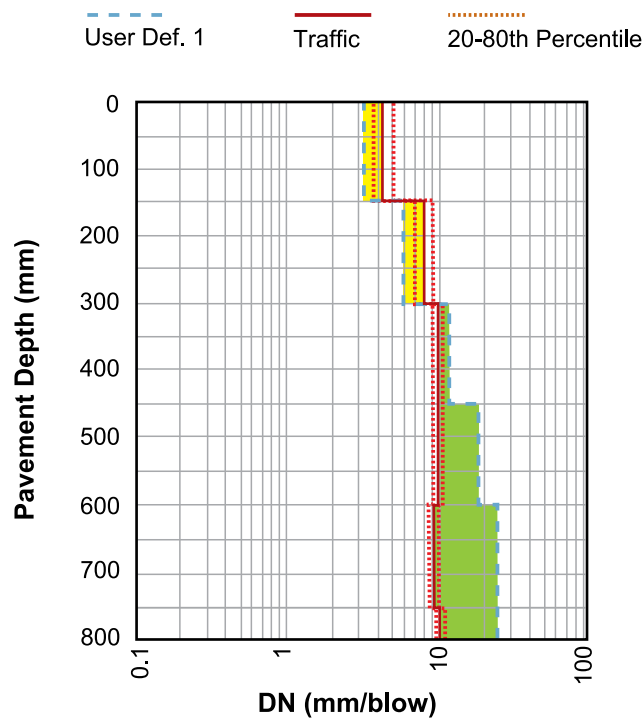

Uniform Section 3: Chainage 6.0 – 7.5

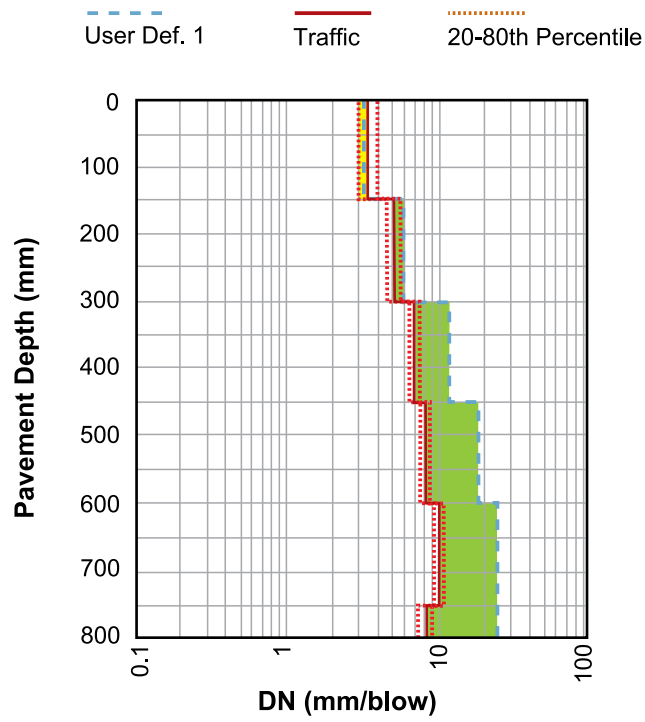

Uniform Section 4: Chainage 7.5 – 10.0

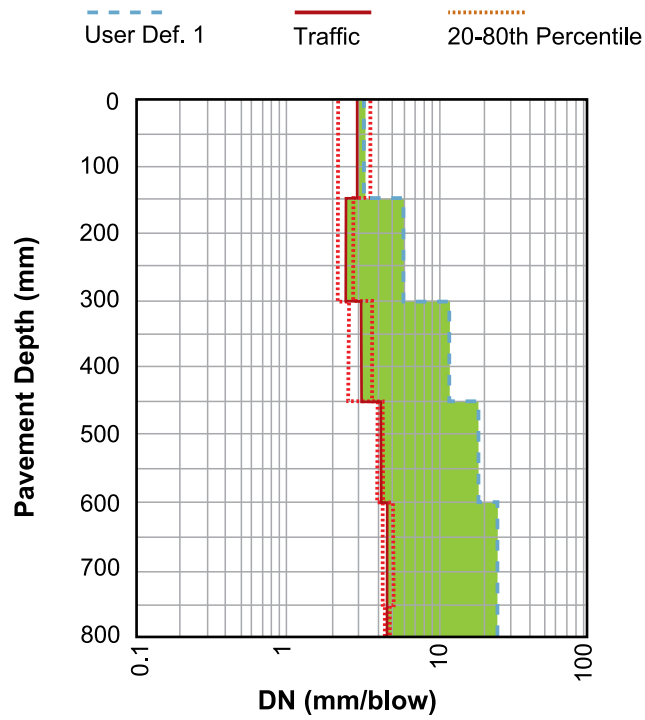

Uniform Section 5: Chainage 10.0 – 12.5

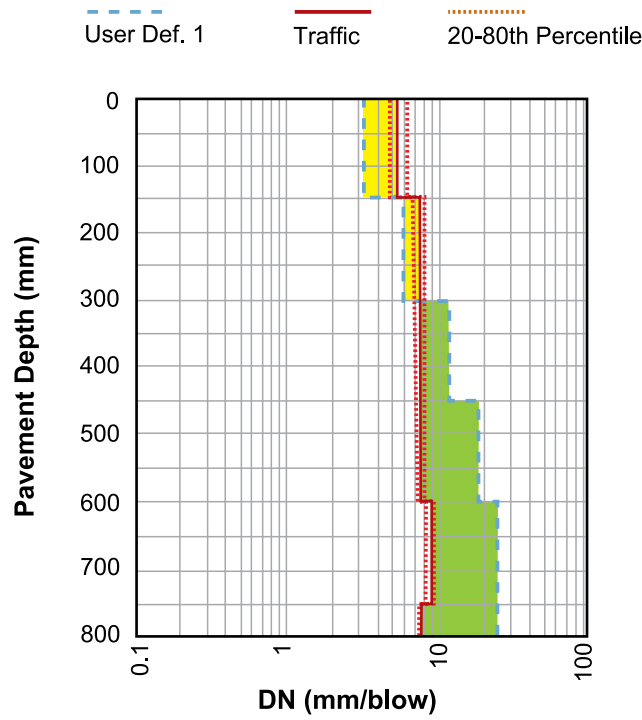

Uniform Section 6: Chainage 12.5 – 14.5

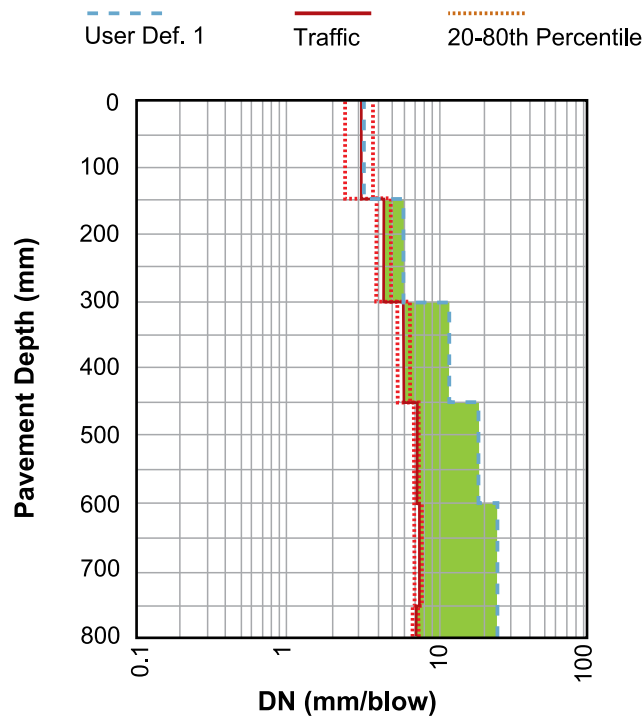

Uniform Section 7: Chainage 14.5 – 17.0

Annex: **B**  
**Glossary  
of Terms**

## PAVEMENT

- Base (or basecourse):** The layer of the pavement structure resting upon, and through which the load is transmitted to, the subbase, subgrade and supporting soil.
- Formation:** The surface of the improved subgrade, in its final shape, upon which the pavement structure, consisting typically of the base course and surfacing is constructed.
- Improved subgrade:** The layer immediately below the pavement which would typically be the re-shaped and compacted wearing course of the unpaved road.
- Subbase:** That layer of the pavement structure that lies above the subgrade and below the base or basecourse.
- Subgrade:** All the material below the pavement and may include the improved subgrade and the in situ subgrade.
- Surfacing:** The uppermost pavement layer which provides the running surface for traffic. It can consist of a bituminous or non-bituminous type of surfacing.

## GENERAL MATERIALS

- Borrow area:** A site from which natural material, other than solid stone, is removed for construction of the road works.
- Naturally occurring gravel/soil:** Material from natural sources used in its original state for the construction of pavement layers.
- Quarry:** An open surface from which natural material, other than solid stone, is removed by drilling and blasting, for construction of the works.

## BITUMINOUS MATERIALS

- Asphalt concrete:** An admixture of bitumen-bound materials normally consisting of a mixture of coarse aggregate, fine aggregate and filler bound with straight-run bitumen. The proportions and grading of the coarse aggregate may be varied to produce different types of mix with differing properties.
- Bituminous binders:** Petroleum derived adhesives used to stick chippings on to a road surface, in surface dressing or to bind together a layer of surfacing or base material.
- Bitumen emulsion:** A binder in which petroleum bitumen, in finely divided droplets, is dispersed in water by means of an emulsifying agent to form a stable mixture.
- Bituminous seal:** A general term for thin bituminous wearing courses made of surface treatments or slurry seals or a combination of both.
- Cut-back bitumen:** Bitumen whose viscosity has been reduced by the addition of a volatile diluent.

<b>Fog spray:</b>	A light application of bitumen emulsion or cut-back, on top of surface dressing to improve the waterproofness of the surfacing and to assist in holding the chippings.
<b>Prime coat:</b>	An application of low viscosity bituminous binder to an absorbent surface, usually the top of the base with the aim of waterproofing the surface being sprayed and to help bind it to the overlying bituminous courses.
<b>Straight-run bitumen:</b>	Bitumen whose viscosity or composition has not been adjusted by blending with solvents or other substance.
<b>Surface dressing:</b>	A surface treatment made of single sized aggregates of crushed material. Can be constructed in single or multiple layers.
<b>Surface treatment:</b>	A general term for thin bituminous wearing courses made by rolling aggregate into a sprayed thin film of bitumen. Aggregates can be made of crushed or natural gravel with a grading depending on the desired type of surface treatment to be produced. Can be constructed in single or multiple layers.
<b>Slurry seal:</b>	A surfacing material which consists of fine aggregate, mineral filler and bitumen emulsion, used in one or two layers, or on top of a single surface dressing (Cape seal).
<b>Sand bitumen:</b>	A base material consisting of a cold, mix-in-place combination of sand and either bitumen emulsion or cutback.
<b>Tack coat:</b>	A light application of bituminous binder to a bituminous surface to provide a bond between this surface and the overlying bituminous course.
<b>Wearing course (bituminous):</b>	The uppermost surfacing layer. Can consist of a bituminous mix or a bituminous seal.

## SOILS AND SOIL TESTS

<b>Atterberg Limits:</b>	Collective name for Liquid Limit and Plastic Limit tests. Originally proposed by A. Atterberg for determining soil sattes.
<b>California Bearing Ratio (CBR):</b>	The value given to an ad-hoc penetration test where the value 100% applies to a standard sample of good quality crushed material.
<b>Clay:</b>	The finest soil fraction. Comprises colloiddally fine, complex silicates formed by the natural decomposition of igneous rocks.
<b>Clay fraction:</b>	That fraction of soil composed of particles smaller in size than 0.002 mm. This is the fraction that generally imparts plasticity to a soil and in appropriate quantities helps bind the material together. Too much clay can lead to unacceptable swelling and shrinkage in response to moisture.

<b>Cohesive soil:</b>	Soil containing sufficient clay or silt particles to impart significant plasticity and cohesion.
<b>Compaction:</b>	The process whereby soil particles are densified, by rolling or other means, to pack more closely together, thus increasing the dry density of the soil.
<b>Dry density (DD):</b>	The mass of the dry material after drying to constant mass at 105 degrees Celsius, contained in a unit volume of moist material.
<b>Dry density/moisture content relationship:</b>	The relationship between the dry density and moisture content of a soil when a given amount of compaction is applied.
<b>Equilibrium moisture content (EMC):</b>	The moisture content at any point in a soil after moisture movements have stabilised in a constructed pavement.
<b>Lateritic:</b>	Soils and rocks containing iron oxides as a major constituent in concentrated form, remaining behind when more soluble products have been leached away.
<b>Linear Shrinkage (LS):</b>	The decrease in one dimension, expressed as a percentage of the original dimension of the soil mass, when the moisture content is reduced from the liquid limit to the oven-fry state.
<b>Liquid Limit (LL):</b>	The moisture content, expressed as a percentage, at which the wet soil fines passes from a plastic to a liquid condition.
<b>Heavy compaction:</b>	Laboratory compaction of a soil sample using a 4.5 kg hammer falling through a height of 115.5 mm to compact a soil in a 150 mm diameter mould.
<b>Moisture content:</b>	The loss in mass, expressed as a percentage of the dry material, when a soil is dried to a constant mass of 105 degrees Celsius.
<b>Optimum moisture content:</b>	That moisture content at which a specified amount of compaction will produce the maximum dry density.
<b>Particle size distribution (grading):</b>	The spread of soil sizes (fraction) in a soil sample from gravel to sand to silt/clay as measured by passing the sample through a nest of standard sieves.
<b>Plastic Limit (PL):</b>	The moisture content at which the damp soil fines pass from a plastic to a solid condition, i.e. when the soil ceases to behave as a plastic material.
<b>Plasticity Index (PI):</b>	LL – PL, an indication of the clay content of soils; the larger the PI, the larger the clay content.
<b>Plasticity Modulus (PM):</b>	A measure of PI x % passing the 0.425 mm sieve.

<b>Plasticity Product (PP):</b>	A measure of $PI \times \%$ passing the 0.075 mm sieve.
<b>Residual soils:</b>	These are the weathered remains of rocks that have undergone no transportation. They are normally sandy or gravelly, with high concentrations of oxides resulting from a leaching process.
<b>Rock:</b>	Hard rigid coherent deposit forming part of the earth's crust, which may be of igneous (e.g. granite, basalt), sedimentary (e.g. limestone, sandstone) or metamorphic (e.g. slate, hornfels) origin and which normally requires blasting. Soft, more easily excavatable materials such as clays, shales and sands which geologically are rocks will be termed soil in an engineering classification.
<b>Sand fraction:</b>	That portion in a soil mass that will pass between the sieve sizes of 2.0 mm and 0.075 mm. In geological terms a sand is between 2.0 and 0.06 mm.
<b>Silt:</b>	Mineral particles deposited as sediment in water and of such size that all will pass the 0.075 mm sieve. Individual particles are indistinguishable to the naked eye.
<b>Silt fraction:</b>	That portion of the soil mass that lies between the sizes 0.06 mm and 0.002 mm.
<b>Soil:</b>	A mixture of inorganic mineral particles together with some water and air, which may be further described as sands, gravels, silts and clays.
<b>Soil moisture suction:</b>	The suction forces which generate the cohesion in fine grained soils below the Liquid Limit.

## TRAFFIC

<b>Design period:</b>	is the period during which the proposed pavement must carry the estimated cumulative number of standard axles without the need for major reconstruction work, except for re-sealing. At the end of this period the pavement should still be in a sufficiently good condition that strengthening will result in a further period of satisfactory traffic-carrying
<b>Equivalence Factor:</b>	of an axle or vehicle is the number of passages of an Equivalent Standard Axle which would cause the same damage to a road as one passage of the axle or vehicle in question.
<b>Equivalent Standard Axle (ESA):</b>	A design concept to enable the damaging effect of a range and number of different axle loads, to be considered in the structural design of a pavement. The equivalent standard axle imposes a load of 8,200 kg.